

TOSHIBA

FILE NO. 810-200747GR

SERVICE MANUAL



HD DVD PLAYER

HD-A20KU *HD-A20KC*



(HD-A20KU)

The above models are classified as green products (*1), as indicated by the underlined serial numbers.
This Service Manual describes replacement parts for the green products. When repairing these green product(s), use the part(s) described in this manual and lead-free solder (*2).

For (*1) and (*2), see the next page.

Apr., 2007 GREEN

(*1)

GREEN PRODUCT PROCUREMENT

The EC is actively promoting the WEEE & RoHS Directives that define standards for recycling and reuse of Waste Electrical and Electronic Equipment and for the Restriction of the use of certain Hazardous Substances. From July 1, 2006, the RoHS Directive will prohibit any marketing of new products containing the restricted substances.

Increasing attention is given to issues related to the global environmental. Toshiba Corporation recognizes environmental protection as a key management tasks, and is doing its utmost to enhance and improve the quality and scope of its environmental activities. In line with this, Toshiba proactively promotes Green Procurement, and seeks to purchase and use products, parts and materials that have low environmental impacts.

Green procurement of parts is not only confined to manufacture. The same green parts used in manufacture must also be used as replacement parts.

(*2)

LEAD-FREE SOLDER

This product is manufactured using lead-free solder as a part of a movement within the consumer products industry at large to be environmentally responsible. Lead-free solder must be used in the servicing and repair of this product.

WARNING

This product is manufactured using lead free solder.

DO NOT USE LEAD BASED SOLDER TO REPAIR THIS PRODUCT !

The melting temperature of lead-free solder is higher than that of leaded solder by 86°F to 104°F (30°C to 40°C). Use of a soldering iron designed for lead-based solders to repair product made with lead-free solder may result in damage to the component and or PCB being soldered. Great care should be made to ensure high-quality soldering when servicing this product especially when soldering large components, through-hole pins, and on PCBs as the level of heat required to melt lead-free solder is high.

LASER BEAM CAUTION LABEL



When the power supply is being turned on, you may not remove this laser cautions label. If it removes, radiation of a laser may be received.

PREPARATION OF SERVICING

Pickup Head consists of a laser diode that is very susceptible to external static electricity.

Although it operates properly after replacement, if it was subject to electrostatic discharge during replacement, its life might be shortened. When replacing, use a conductive mat, soldering iron with ground wire, etc. to protect the laser diode from damage by static electricity.

And also, the LSI and IC are same as above.

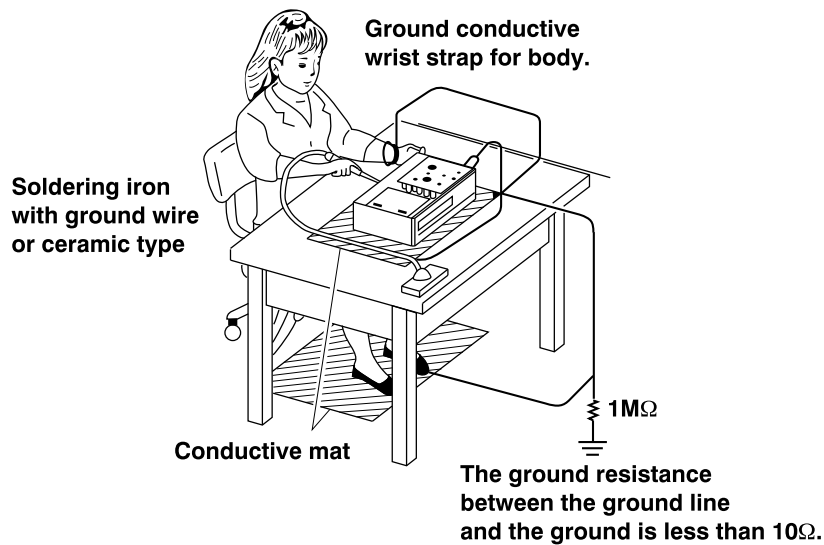

- Dolby features manufactured under license from Dolby Laboratories. Dolby and the double-D symbol are trademarks of Dolby Laboratories.
- Manufactured under license from DTS, Inc. under one or more of the following U.S. Pat. No's. 5,451,942; 5,956,674; 5,974,380; 5,978,762; 6,226,616; 6,487,535 and other U.S. and world-wide patents issued and pending. "DTS" and "DTS Digital Surround" are registered trademarks of DTS, Inc.
- HDMI, the HDMI logo and High-Definition Multimedia Interface are trademarks or registered trademarks of HDMI Licensing LLC.
- SHARC is a registered trademark and Melody is a trademark of Analog Devices, Inc.
- All other brand and product names mentioned in this manual are trademarks and/or registered trademarks of their respective holders.

SAFETY NOTICE

SAFETY PRECAUTIONS

LEAKAGE CURRENT CHECK

Plug the AC line cord directly into a 120V AC outlet (do not use an isolation transformer for this check). Use an AC voltmeter, having 5000 Ω per volt or more sensitivity.

Connect a 1500 Ω 10 W resistor, paralleled by a 0.15 μ F 150V AC capacitor between a known good earth ground (water pipe, conduit, etc.) and all exposed metal parts of cabinet (antennas, handle bracket, metal cabinet screwheads, metal overlays, control shafts, etc.).

Measure the AC voltage across the 1500 Ω resistor.

The test must be conducted with the AC switch on and then repeated with the AC switch off. The AC voltage indicated by the meter may not exceed 0.3 V. A reading exceeding 0.3 V indicates that a dangerous potential exists, the fault must be located and corrected.

Repeat the above test with the DVD PLAYER power plug reversed.

NEVER RETURN A DVD PLAYER TO THE CUSTOMER WITHOUT TAKING NECESSARY CORRECTIVE ACTION.

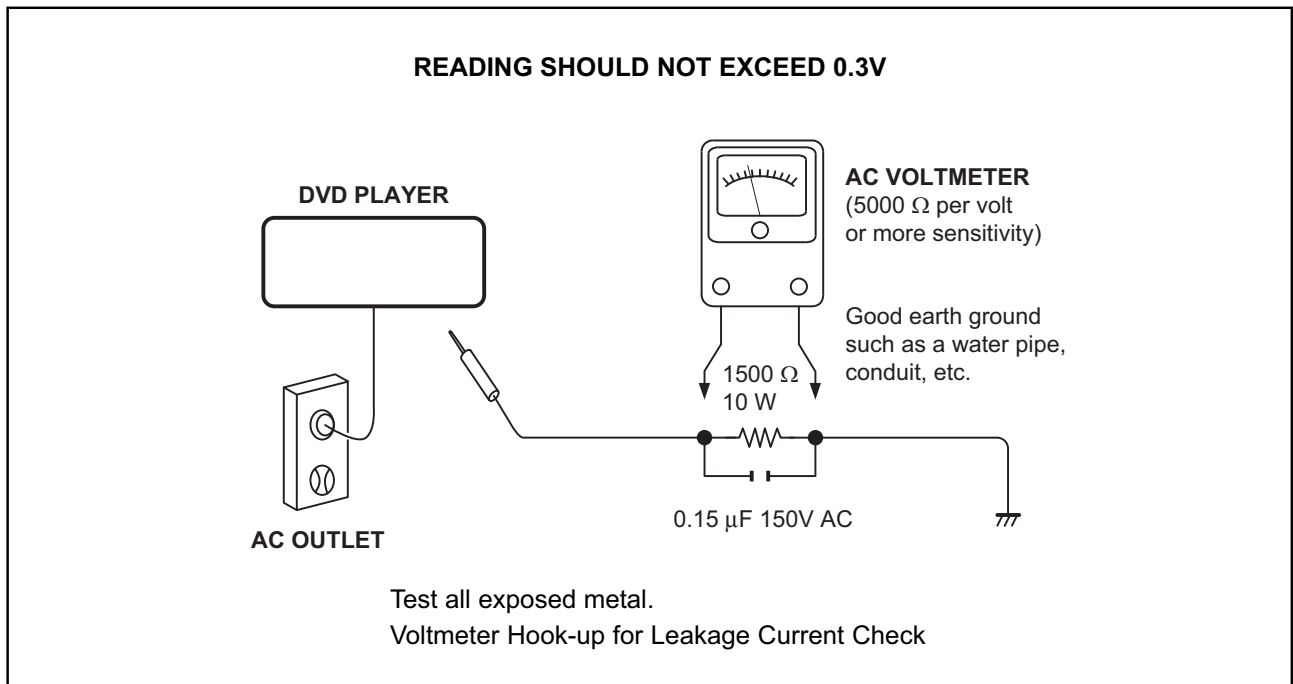

The lightning flash with arrowhead symbol, within an equilateral triangle, is intended to alert the user to the presence of uninsulated “dangerous voltage” within the product’s enclosure that may be of sufficient magnitude to constitute a risk of electric shock to persons.



The exclamation point within an equilateral triangle is intended to alert the user to the presence of important operating and maintenance (servicing) instructions in the literature accompanying the appliance.

CONTENTS

SECTION 1 GENERAL DESCRIPTIONS

- 1. OPERATING INSTRUCTIONS
 - 2. LOCATION OF MAIN PARTS
 - 2-1. Location of Main Parts
 - 2-2. Location of PC Boards
-

SECTION 2 PART REPLACEMENT PROCEDURES

- 1. REPLACEMENT OF MECHANICAL PARTS
 - 1-1. Front Panel, Front PC Boards
 - 1-2. Main/Power PC Boards
 - 1-3. DVD Drive
 - 2. WIRING CONNECTION DIAGRAM
 - 2-1. Wiring Connection Diagram
 - 2-2. Supplementary Instructions for Reassembling
-

SECTION 3 SERVICING DIAGRAMS

- 1. CIRCUIT SYMBOLS AND SUPPLEMENTARY EXPLANATION
 - 1-1. Precautions for Part Replacement
 - 1-2. Solid Resistor Indication
 - 1-3. Capacitance Indication
 - 1-4. Inductor Indication
 - 1-5. Waveform and Voltage Measurement
 - 1-6. Others
 - 2. PRINTED WIRING BOARD AND SCHEMATIC DIAGRAM
 - 3. SYSTEM BLOCK DIAGRAM
 - 4. CIRCUIT DIAGRAMS
 - 4-1. Power Supply Circuit Diagram
 - 4-2. Front Circuit Diagram
 - 4-2-1. Front FIP Circuit Diagram
 - 4-2-2. Power Switch Circuit Diagram
 - 4-2-3. Front Switch/USB Circuit Diagram
 - 4-3. ATAPI Conversion Circuit Diagram
 - 4-4. Main Circuit Diagram
 - 4-4-1. AV Output Circuit Diagram
 - 4-4-2. Timer Circuit Diagram
 - 5. PC BOARDS
 - 5-1. Front FIP PC Board
 - 5-2. Power Switch PC Board
 - 5-3. Front Switch/USB PC Board
 - 5-4. ATAPI PC Board
-

SECTION 4 PARTS LIST

SAFETY PRECAUTION

NOTICE

ABBREVIATIONS

1. EXPLODED VIEWS

- 1-1. Packing Assembly
- 1-2. Chassis Assembly

2. PARTS LIST

SECTION 1 GENERAL DESCRIPTIONS

1. OPERATING INSTRUCTIONS

Please refer to the owner's manual about the contents.

2. LOCATION OF MAIN PARTS

2-1. Location of Main Parts

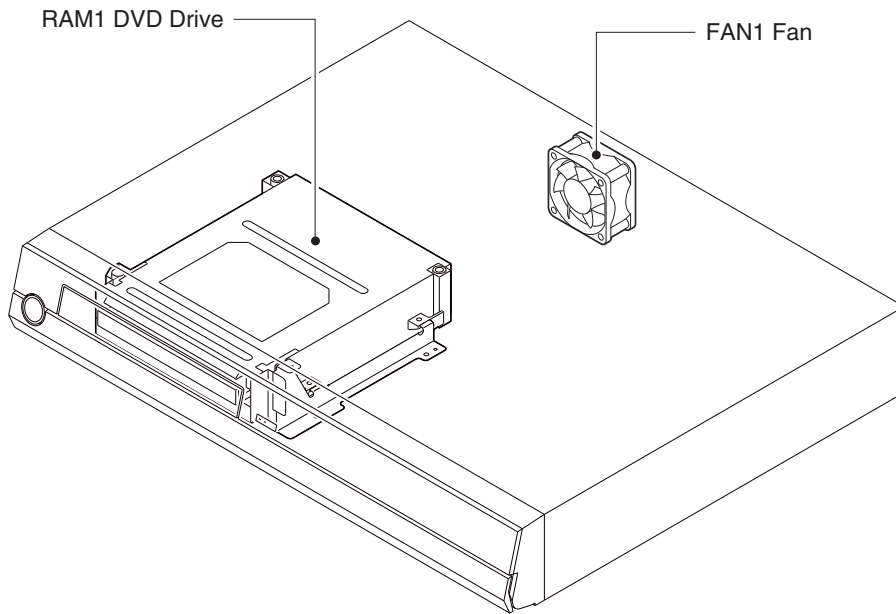

Fig. 1-2-1

2-2. Location of PC Boards

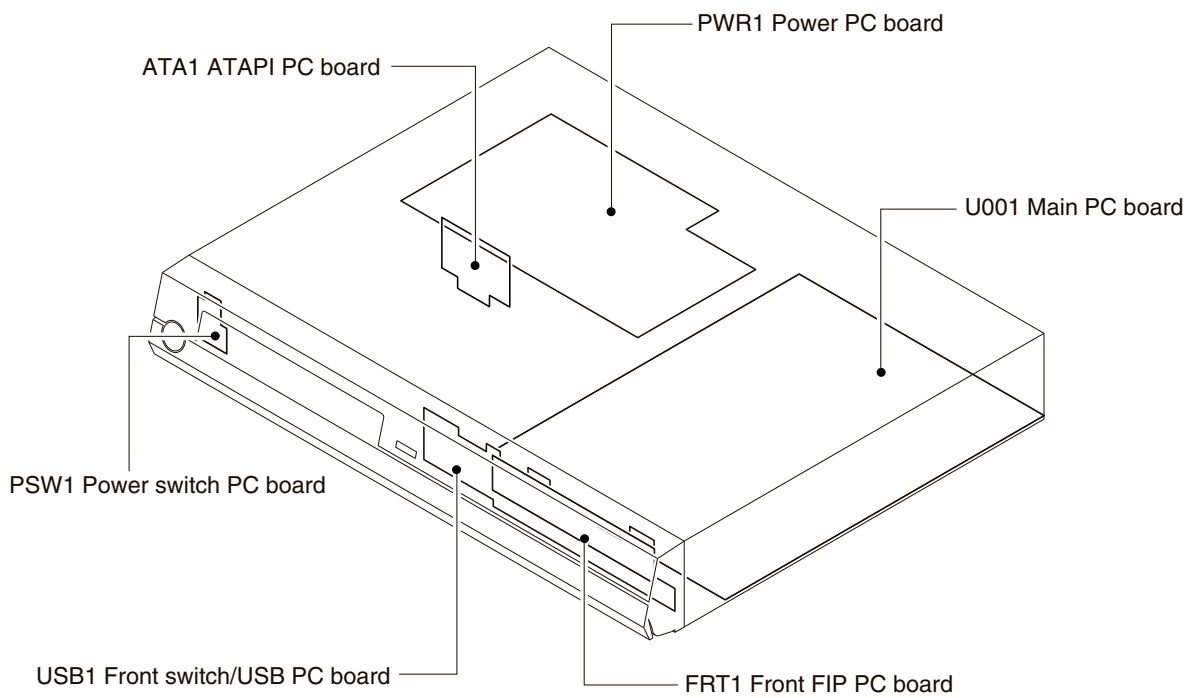

Fig. 1-2-2

SECTION 2

PART REPLACEMENT PROCEDURES

CAUTIONS BEFORE STARTING PART REPLACEMENT

Electronic parts are susceptible to static electricity and may easily be damaged, so do not forget to ground as required. Many screws are used inside the unit. To prevent the screws from missing or dropping, etc. always use a magnetized screwdriver in servicing. Several kinds of screws are used and some of them need special cautions. That is, take care of the tapping screws securing molded parts and fine pitch screws used to secure metal parts. If they are used improperly, the screw holes will be easily damaged and the parts can not be fixed.

1. REPLACEMENT OF MECHANICAL PARTS

Note:

- Circled numbers in the figure show the main disassembly procedure. Refer to them when disassembling.

1-1. Front Panel, Front PC Boards

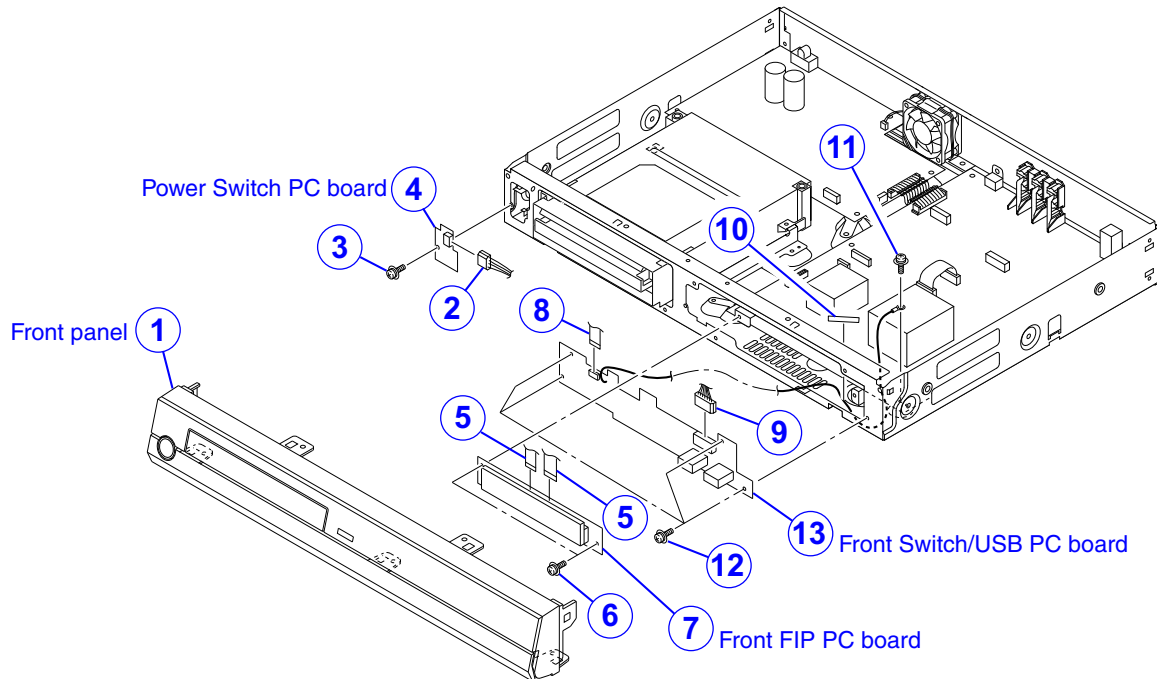

Fig. 2-1-1

1-2. Main/Power PC Boards

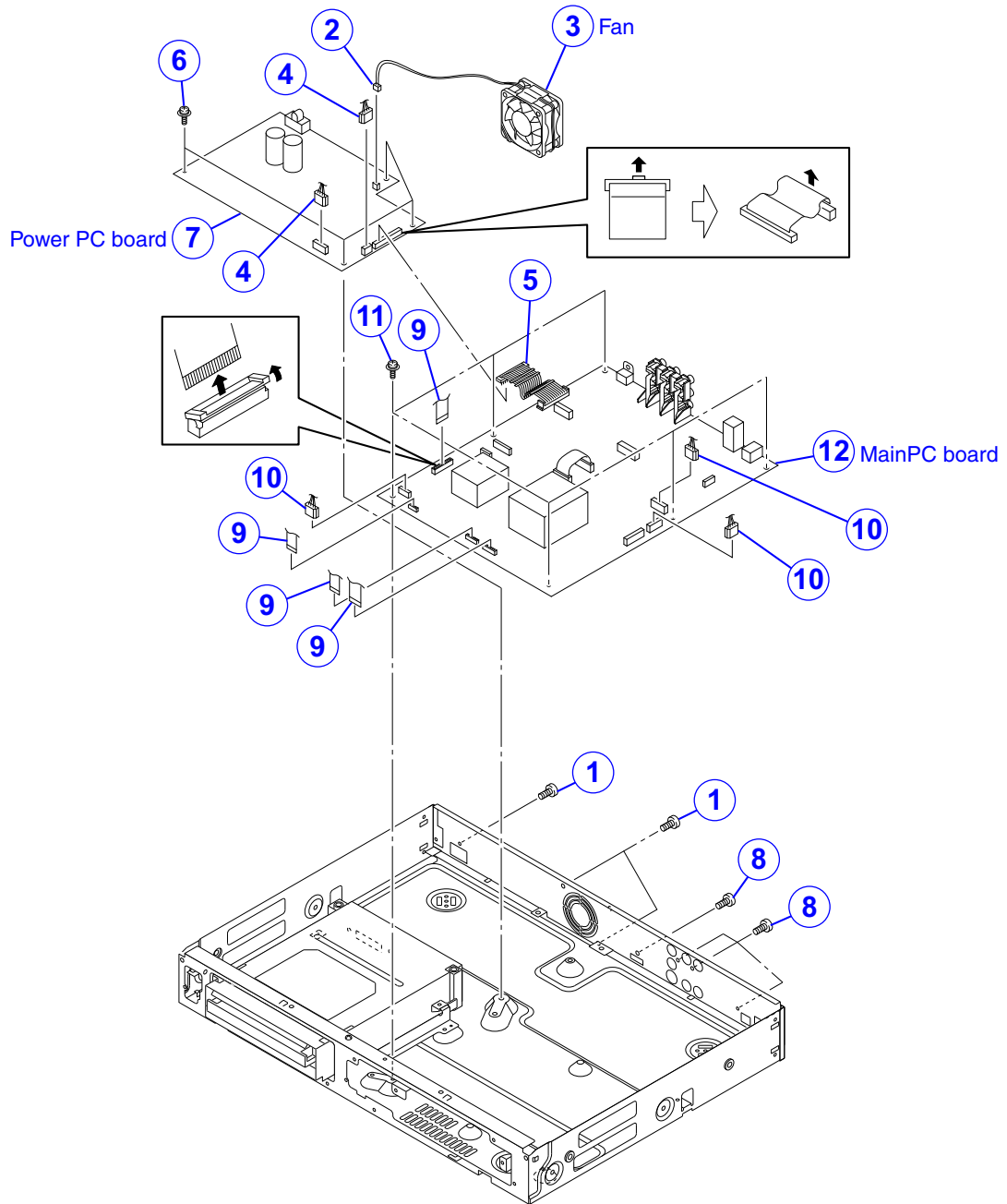

Fig. 2-1-2

1-3. DVD Drive

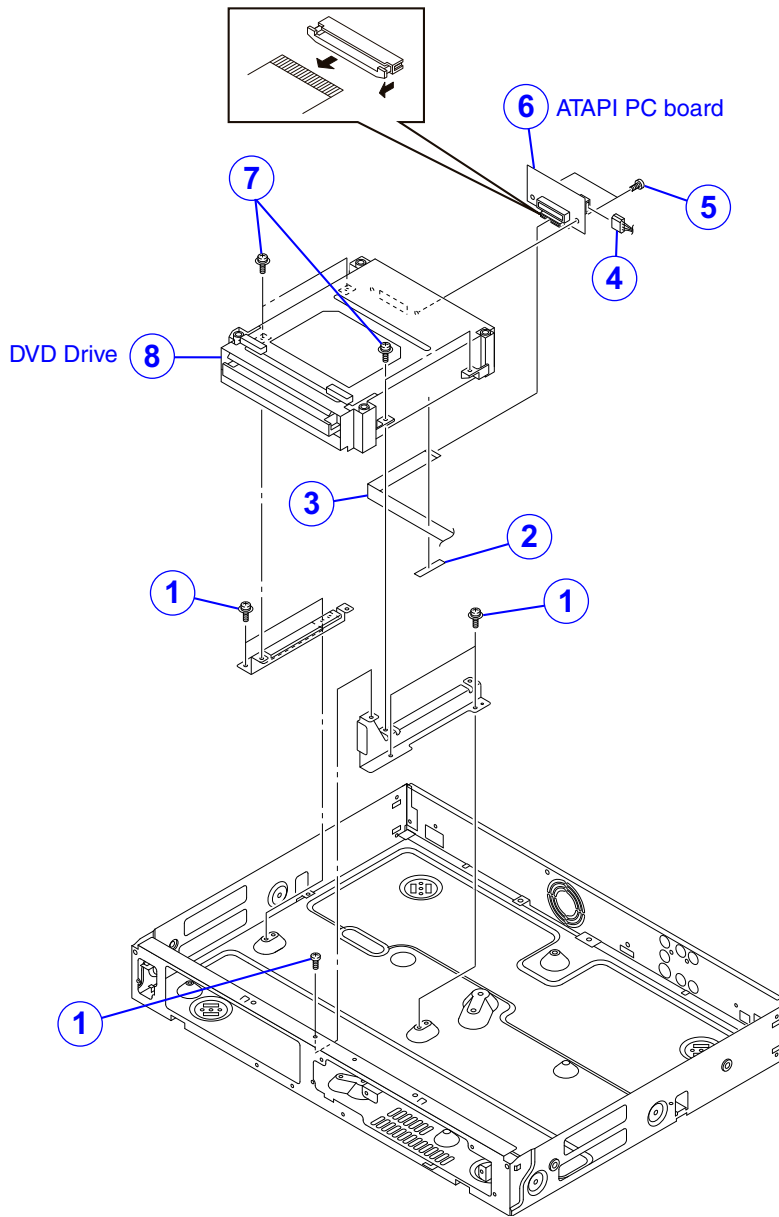

Fig. 2-1-3

2. WIRING CONNECTION DIAGRAM

2-1. Wiring Connection Diagram

After the servicing is complete, return the wiring to its original state by using the diagram below as a reference.

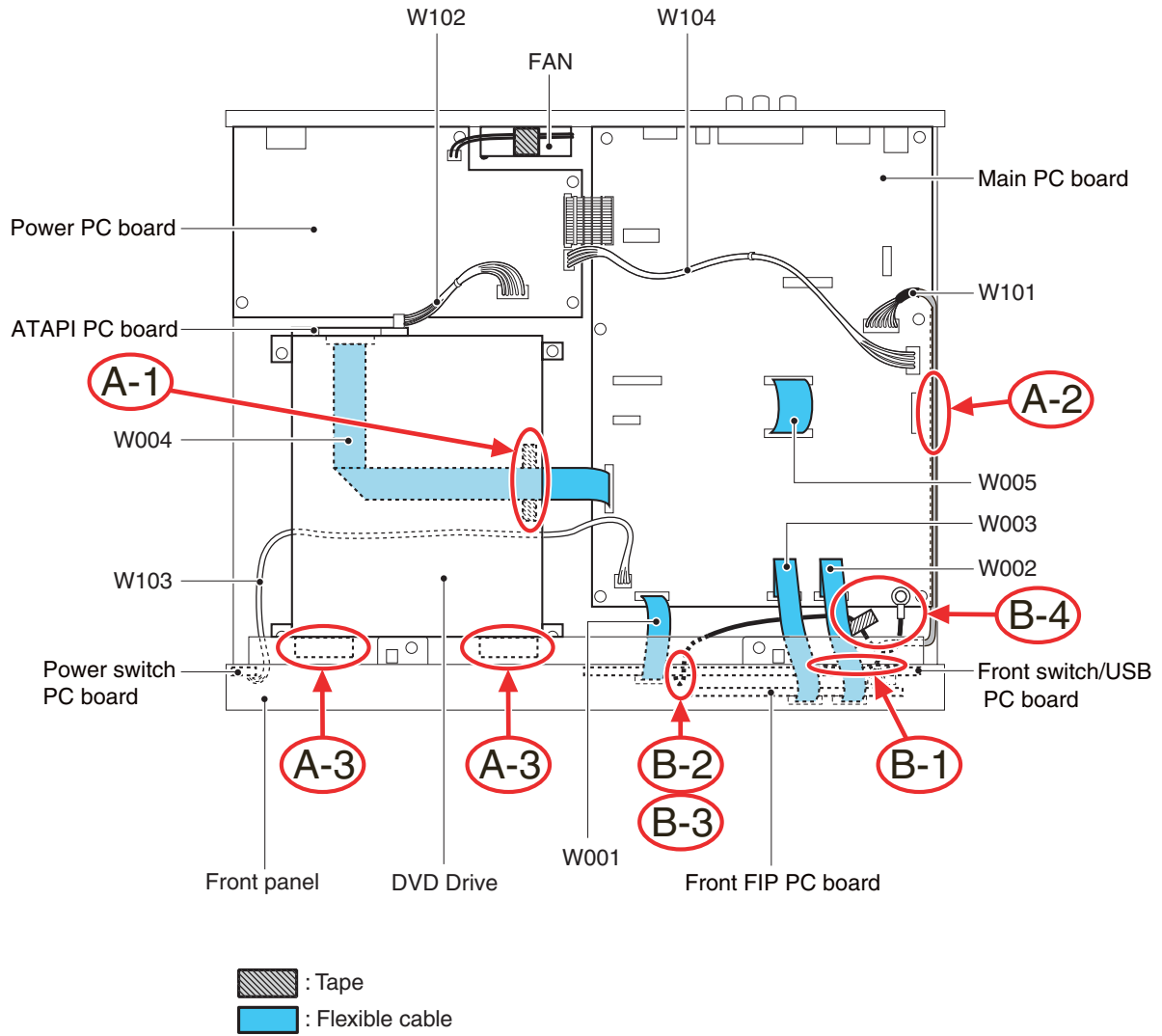
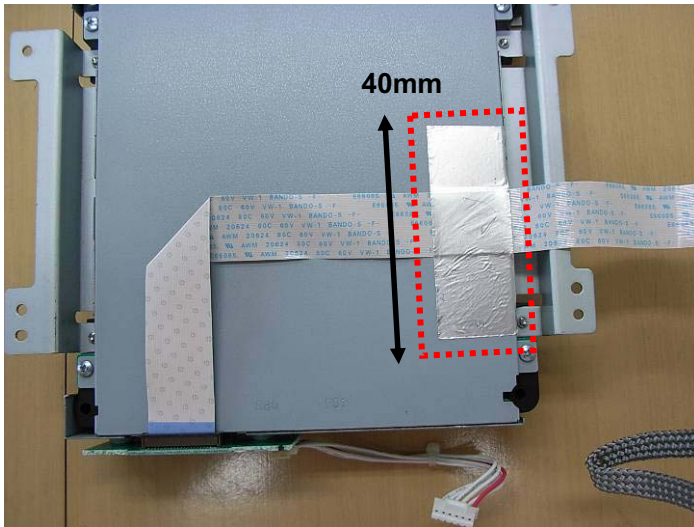

Fig. 2-2-1

2-2. Supplementary Instructions for Reassembling

A-1. Fix the FFC (W004) with the aluminum tape (ALT-25T,40mm).



A-2. Insert the USB wire (W101) to the space of main unit and chassis.

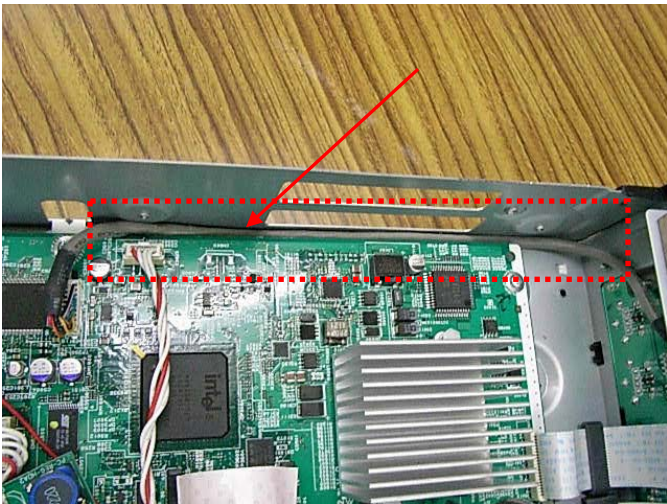

A-3. Paste gaskets to the following positions in the upper side of drive.

(Gasket : SSTG10-10 L25HC(GD9D0000080))

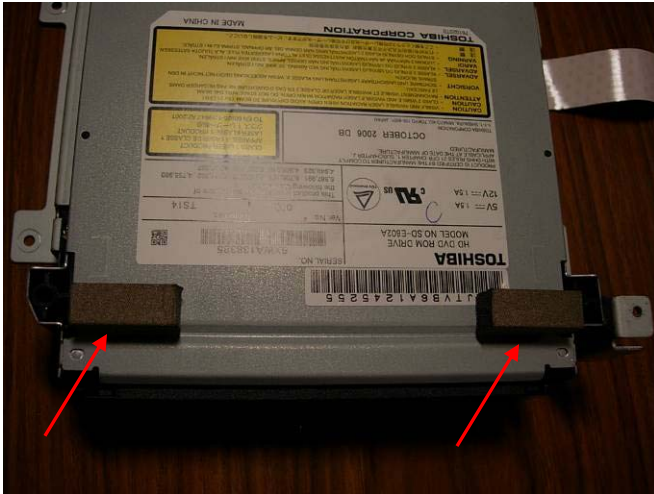

Paste gasket to the position where a semicircle part of the molding hole of this drive correspond to the edge of gasket.

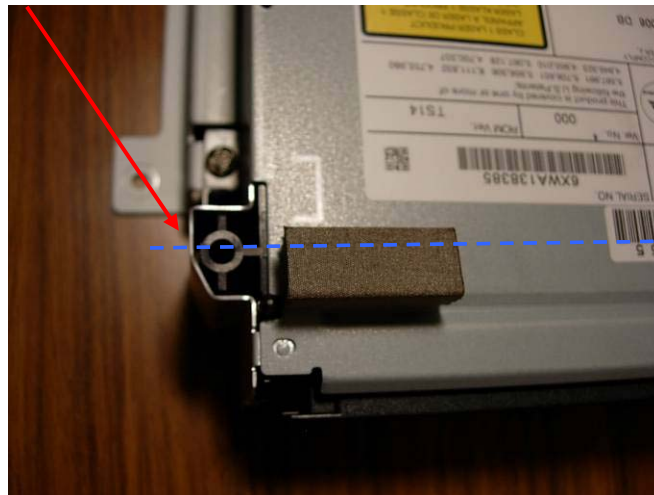

B-1. Paste insulating tape (PM0019453010 INSULATION-TAPE) to the signal line (Pin 1 – Pin 4) of USB Jack (J101,J102).

(The solder side of GND of the USB jack (PC-FRONT_SW_USB) and the signal line (Pin 1 – Pin 4) of a USB jack are insulated)

Note: Stick it not to paste the tape on the solder side of GND of USB Jack (J101,J102), and to cover only USB Jack's signal line (Pin 1 – Pin 4).

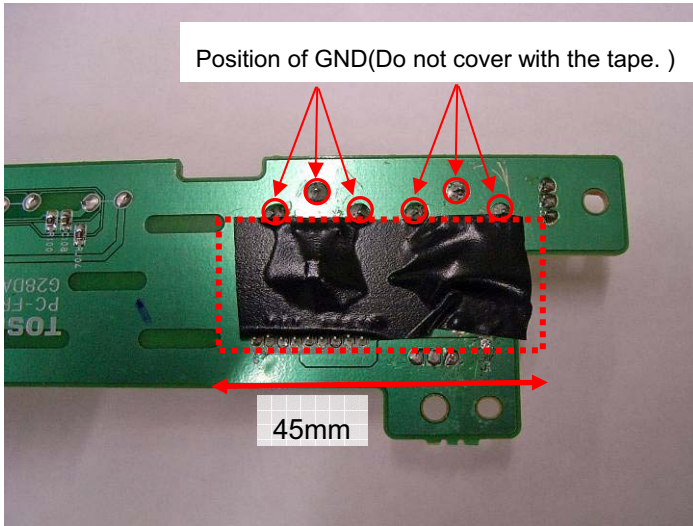

B-2. Attach the earth wire (P90D00001210:AWG22M3L220BK) to W172 of the front unit.

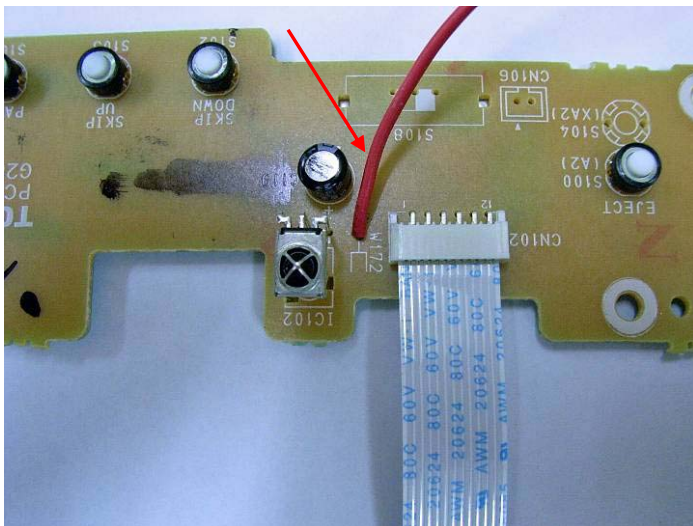

B-3. The earth wire is drawn out to the main unit side as follows.

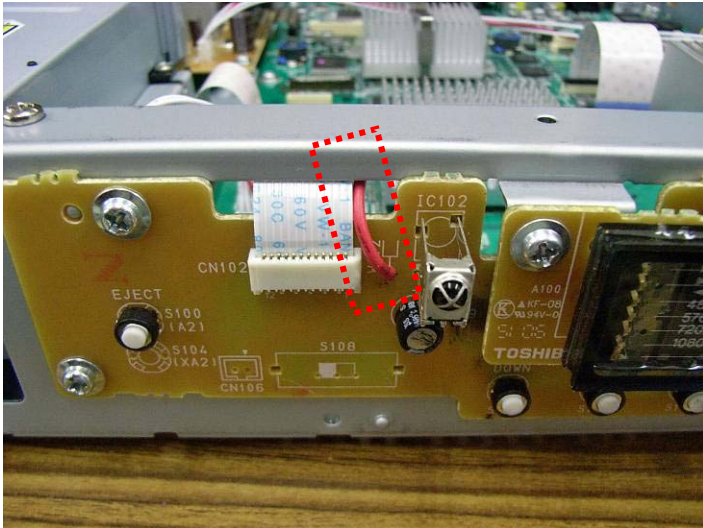

B-4. Fix the earth wire with the screw of main unit (right side front).
The earth wire is fixed to the chassis with a pet tape.

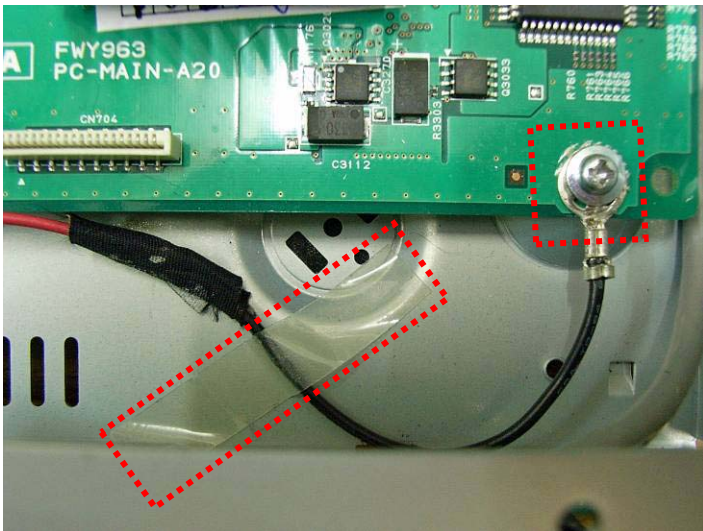

SECTION 3 SERVICING DIAGRAMS

1. CIRCUIT SYMBOLS AND SUPPLEMENTARY EXPLANATION

1-1. Precautions for Part Replacement

- In the schematic diagram, parts marked \triangle (ex. \triangle F801) are critical part to meet the safety regulations, so always use the parts bearing specified part codes (SN) when replacing them.
- Using the parts other than those specified shall violate the regulations, and may cause troubles such as operation failures, fire etc.

1-2. Solid Resistor Indication

Unit	None Ω K $k\Omega$ M $M\Omega$
Tolerance	None $\pm 5\%$ B $\pm 0.1\%$ C $\pm 0.25\%$ D $\pm 0.5\%$ F $\pm 1\%$ G $\pm 2\%$ K $\pm 10\%$ M $\pm 20\%$
Rated Wattage	(1) Chip Parts None 1/16W (2) Other Parts None 1/6W Other than above, described in the Circuit Diagram.
Type	None Carbon film S Solid R Oxide metal film M Metal film W Cement FR Fusible

Eg. 1

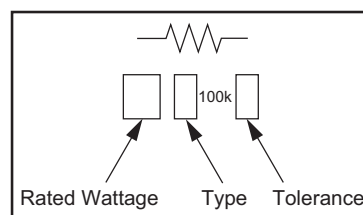

Fig. 3-1-1

1-3. Capacitance Indication

Symbol	$\begin{array}{l} \text{---} \text{+} \\ \text{---} \end{array}$ Electrolytic, Special electrolytic $\begin{array}{l} \text{---} \text{NP} \\ \text{---} \end{array}$ Non polarity electrolytic $\begin{array}{l} \text{---} \text{---} \\ \text{---} \end{array}$ Ceramic, plastic $\begin{array}{l} \text{---} \text{---} \\ \text{---} \end{array}$ Film $\begin{array}{l} \text{---} \text{---} \\ \text{---} \end{array}$ Trimmer
Unit	None F μ μF p pF
Rated voltage	None 50V For other than 50V and electrolytic capacitors, described in the Circuit Diagram.
Tolerance	(1) Ceramic, plastic, and film capacitors of which capacitance are more than 10 pF. None $\pm 5\%$ or more B $\pm 0.1\%$ C $\pm 0.25\%$ D $\pm 0.5\%$ F $\pm 1\%$ G $\pm 2\%$ (2) Ceramic, plastic, and film capacitors of which capacitance are 10 pF or less. None more than ± 5 pF B ± 0.1 pF C ± 0.25 pF (3) Electrolytic, Trimmer Tolerance is not described.
Temperature characteristic (Ceramic capacitor)	None SL For others, temperature characteristics are described. (For capacitors of 0.01 μF and no indications are described as F.)
Static electricity capacity (Ceramic capacitor)	Sometimes described with abbreviated letters as shown in Eg. 3.

Eg. 2

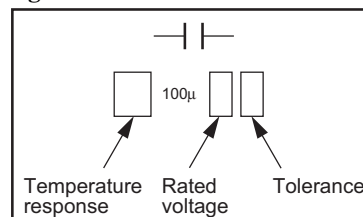

Fig. 3-1-2

Eg. 3

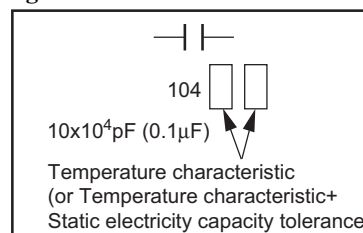

Fig. 3-1-3

1-4. Inductor Indication

Unit	None H
	μ μH
	m mH
Tolerance	None ±5%
	B ±0.1%
	C ±0.25%
	D ±0.5%
	F ±1%
	G ±2%
	K ±10%
	M ±20%

Eg. 4

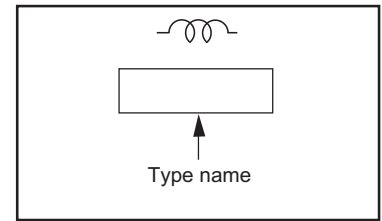

Fig. 3-1-4

1-5. Waveform and Voltage Measurement

- The waveforms for CD/DVD and RF shown in the circuit diagrams are obtained when a test disc is played back.
- All voltage values except the waveforms are expressed in DC and measured by a digital voltmeter.

1-6. Others

- The parts indicated with "NC" or "KETU" etc. are not used in the circuits of this model.

Eg. 5

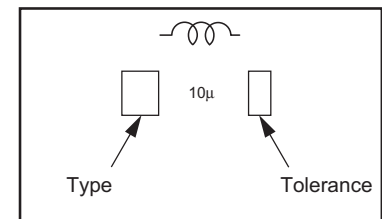

Fig. 3-1-5

3. SYSTEM BLOCK DIAGRAM

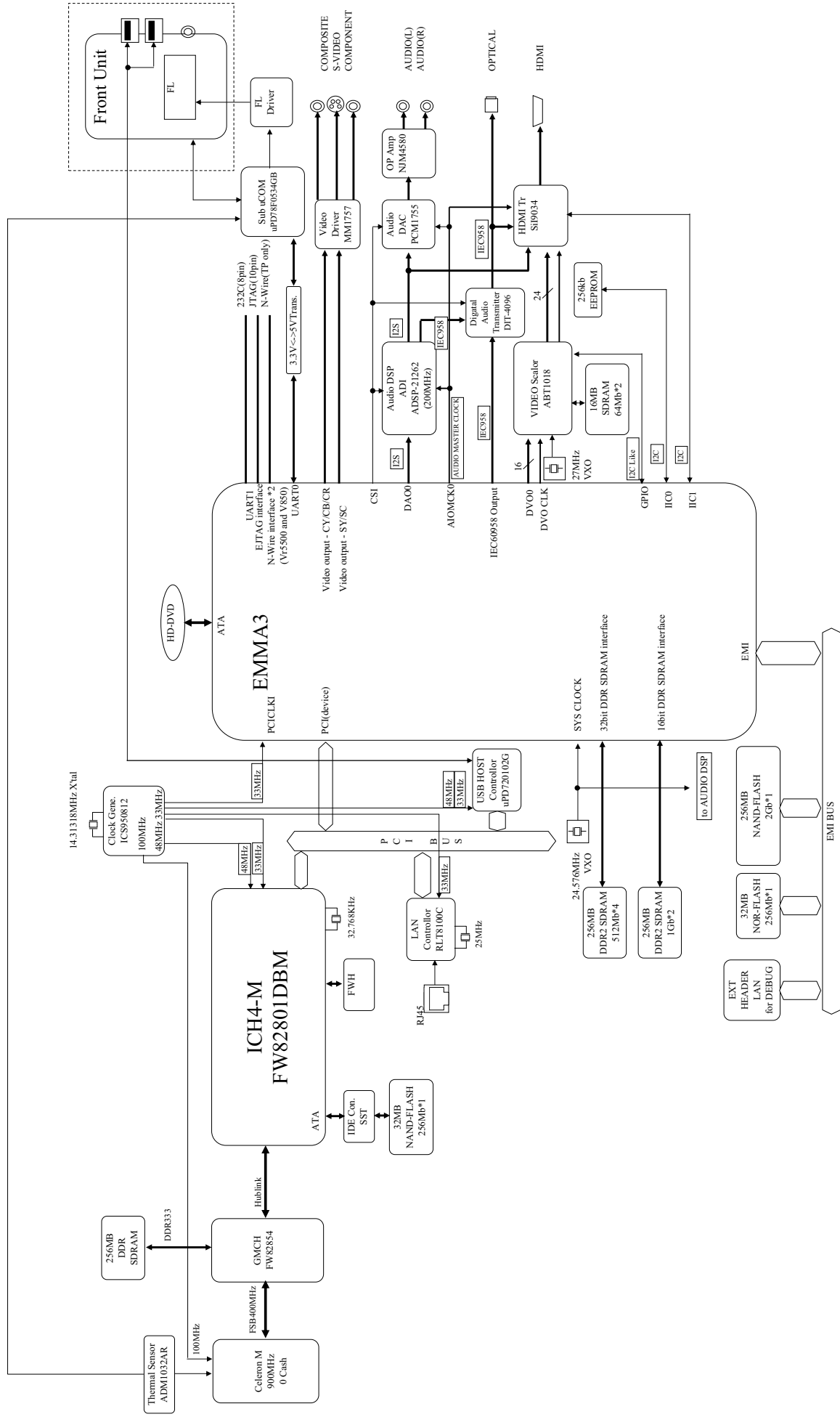

Fig.3-3-1

4. CIRCUIT DIAGRAMS

4-1. Power Supply Circuit Diagram

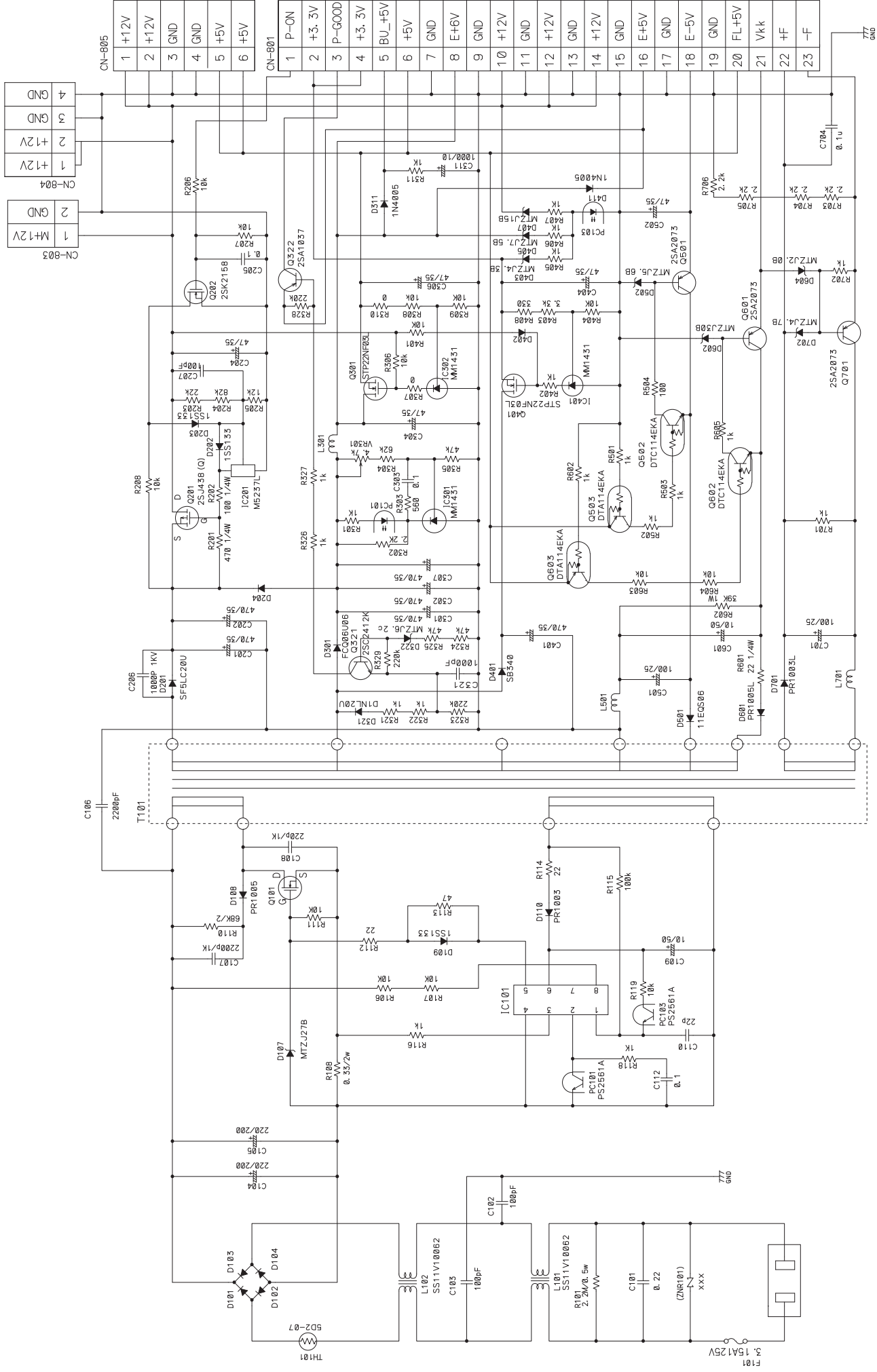

Fig. 3-4-1

4-2-2. Power Switch Circuit Diagram

	HD-A2 HD-A20	HD-XA2
D121	Use	Not use
D122	Not use	Use

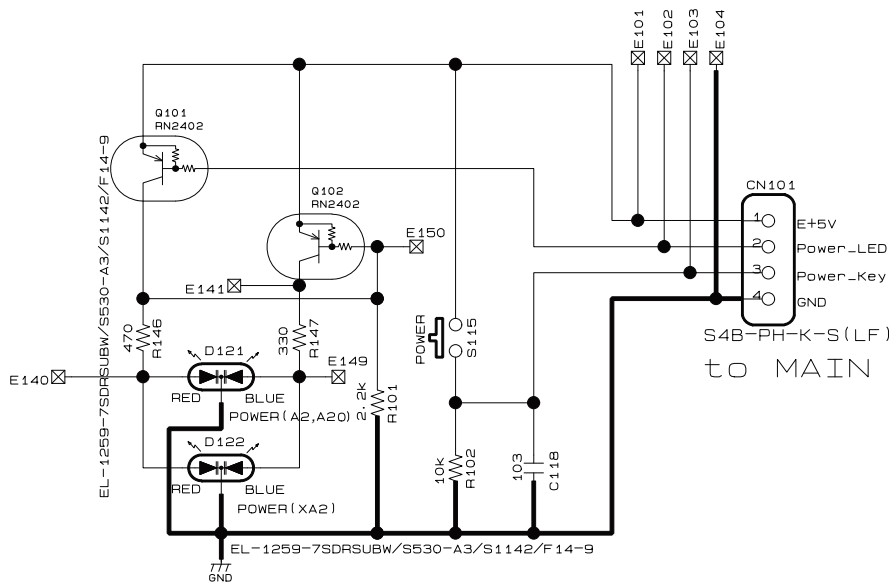

Fig. 3-4-3

4-2-3. Front Switch/USB Circuit Diagram

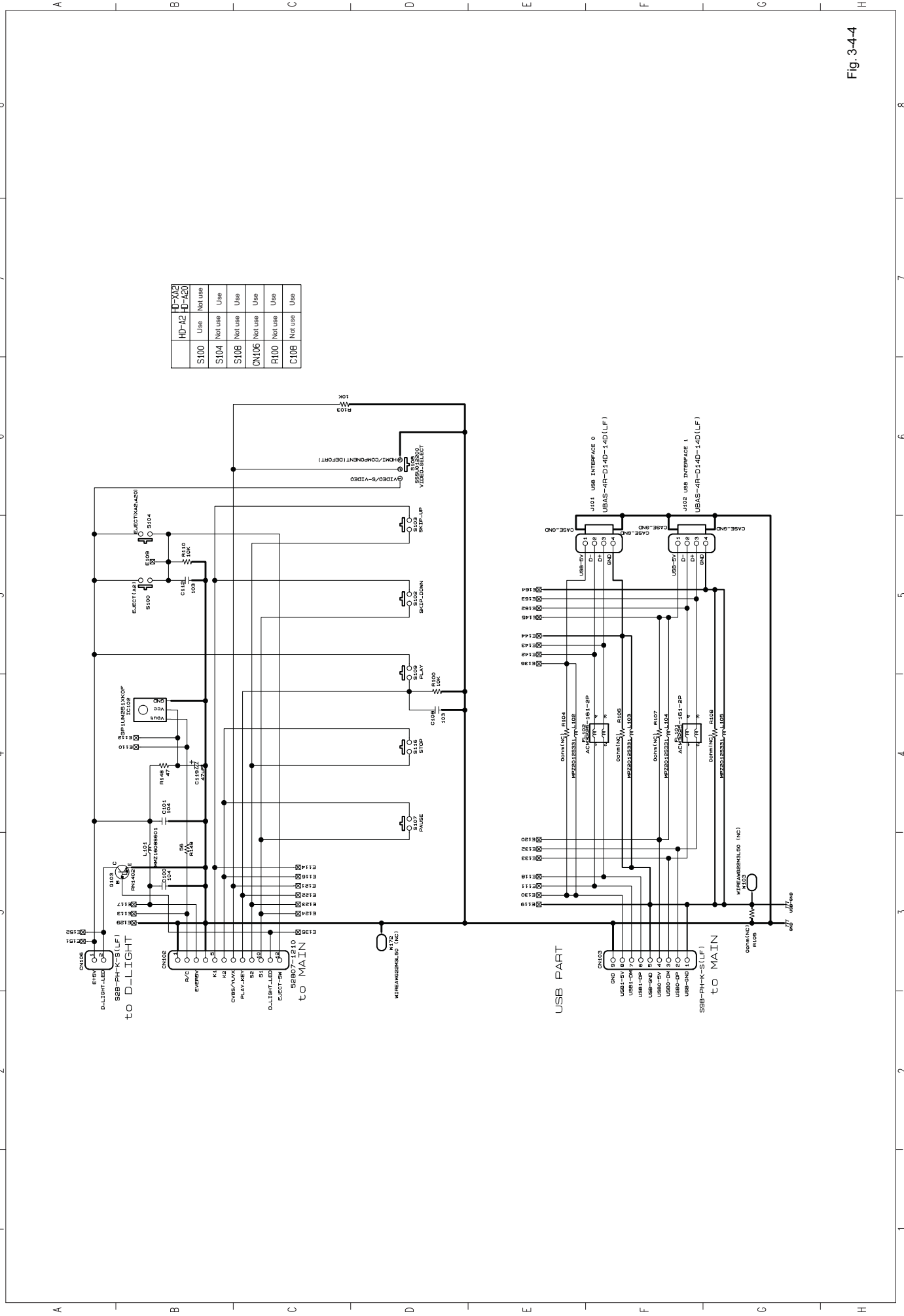

Fig. 3-4-4

4-3. ATAPI Conversion Circuit Diagram

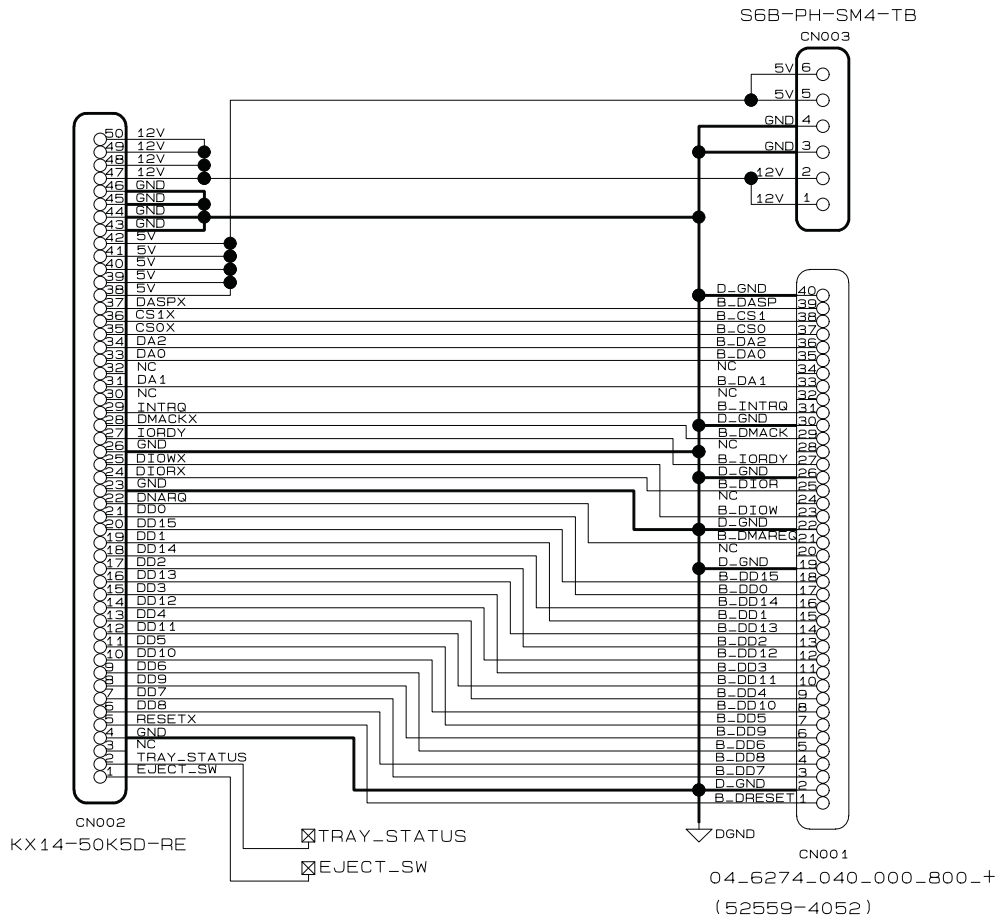

Fig. 3-4-5

4-4. Main Circuit Diagram
4-4-1. AV Output Circuit Diagram

Note: The main circuit diagrams describe only part of information.

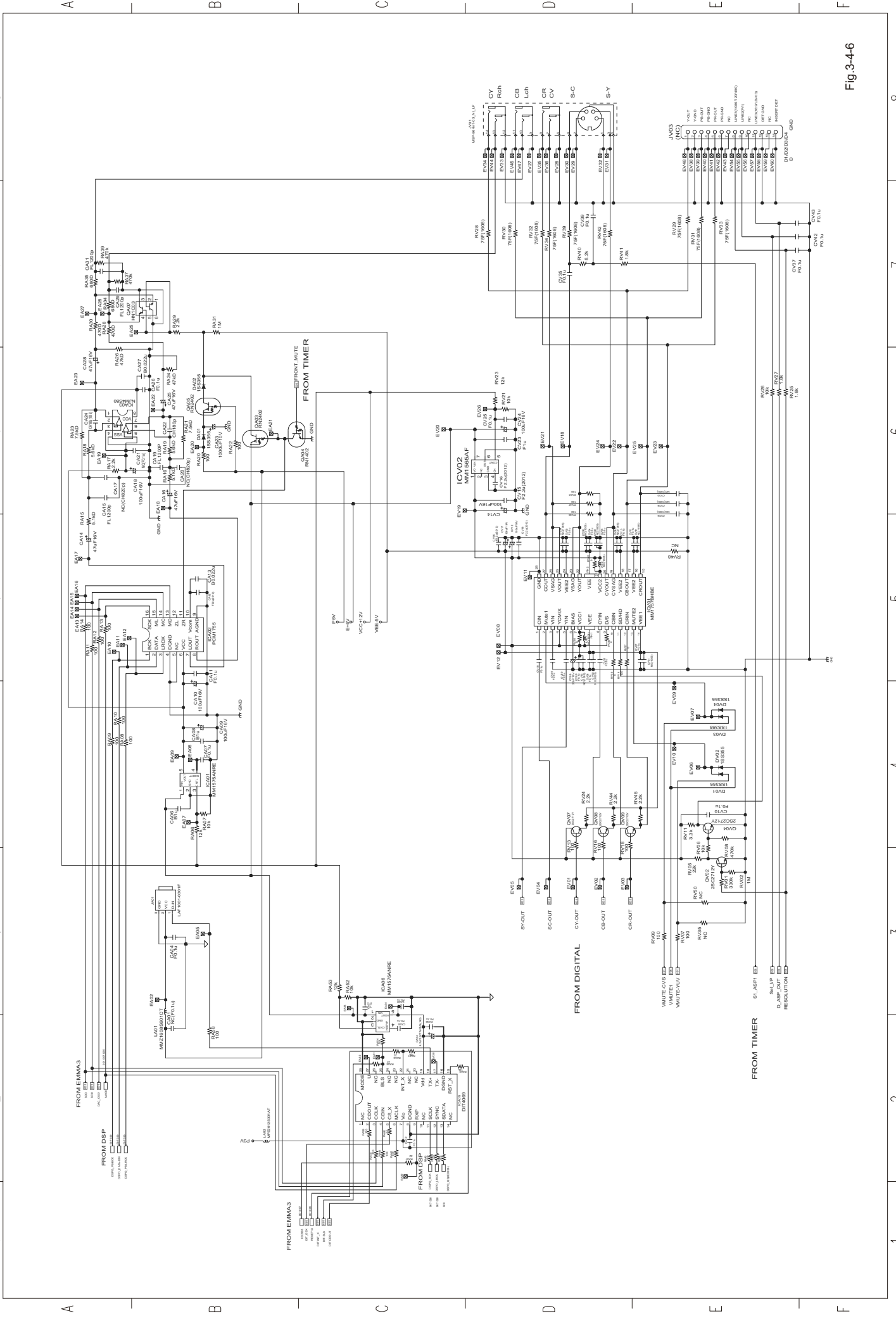
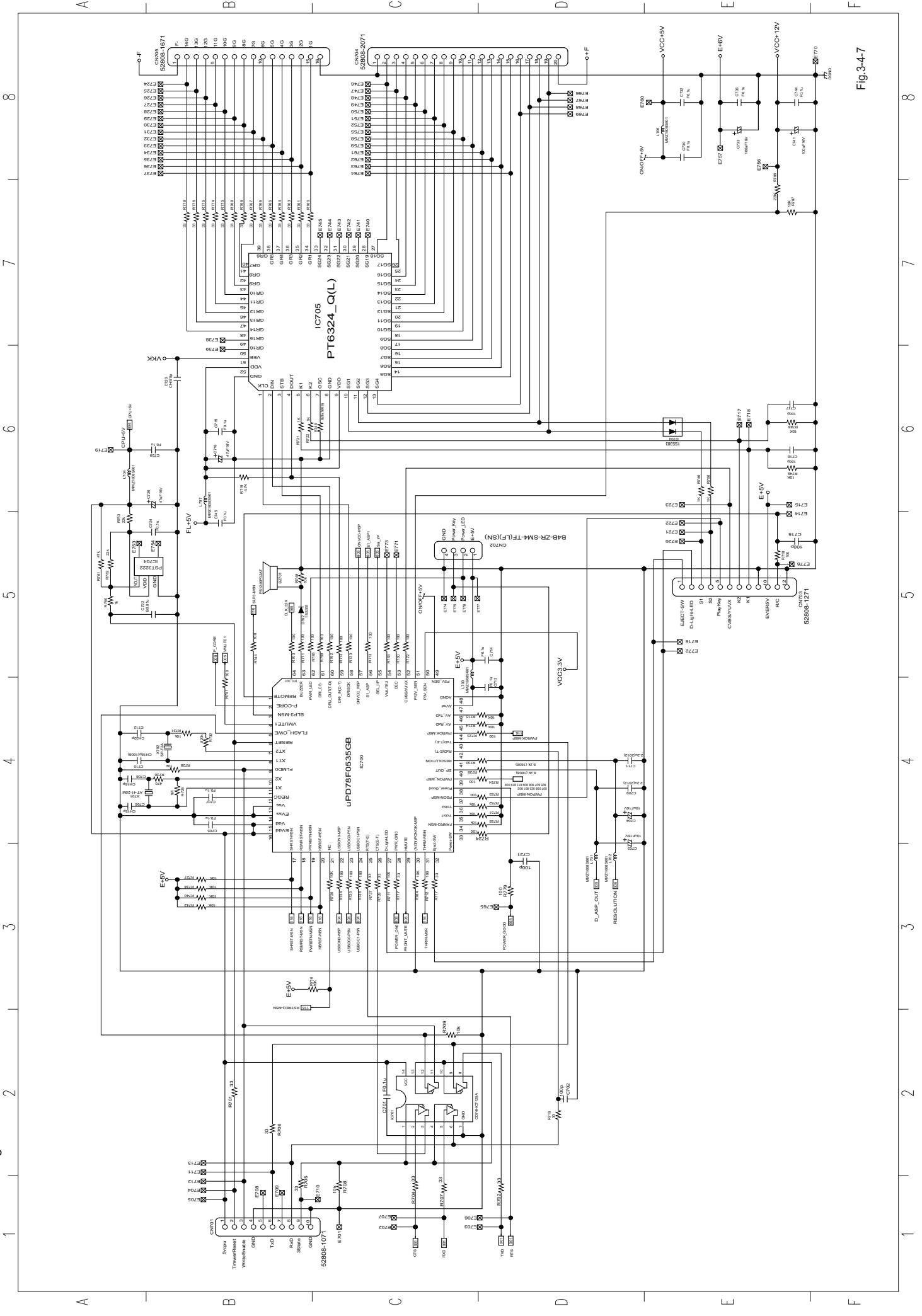

Fig.3-4-6

4-4-2. Timer Circuit Diagram



A

5. PC BOARDS

5-1. Front FIP PC Board

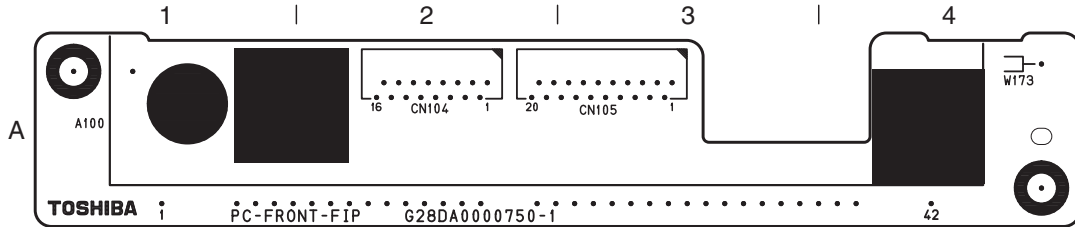

Fig. 3-5-1 Front FIP PC Board (Top side)

B

C

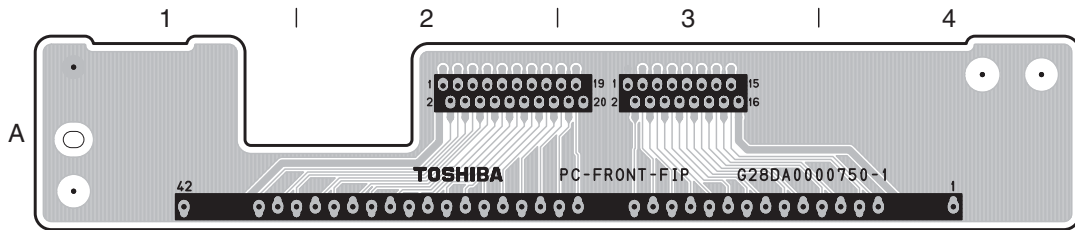

Fig. 3-5-2 Front FIP PC Board (Bottom side)

D

5-2. Power Switch PC Board

E

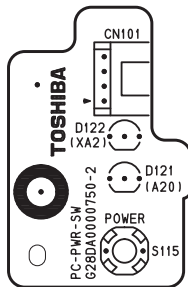

Fig. 3-5-3 Power Switch PC Board (Top side)

F

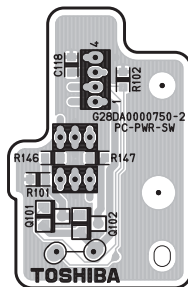

Fig. 3-5-4 Power Switch PC Board (Bottom side)

G

5-3. Front Switch/USB PC Board

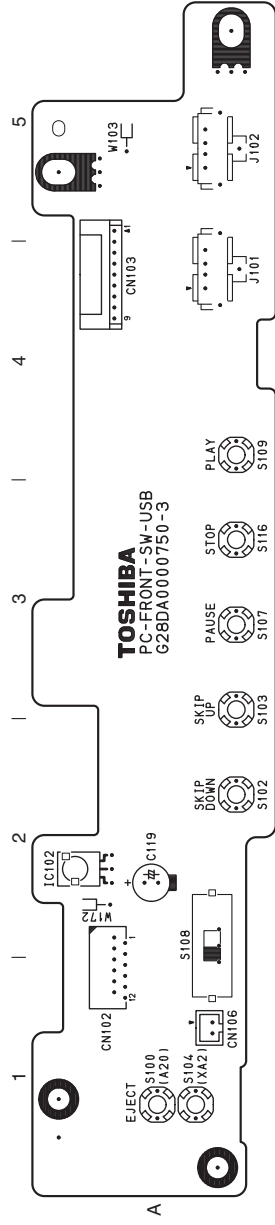

Fig. 3-5-5 Front Switch/USB PC Board (Top side)

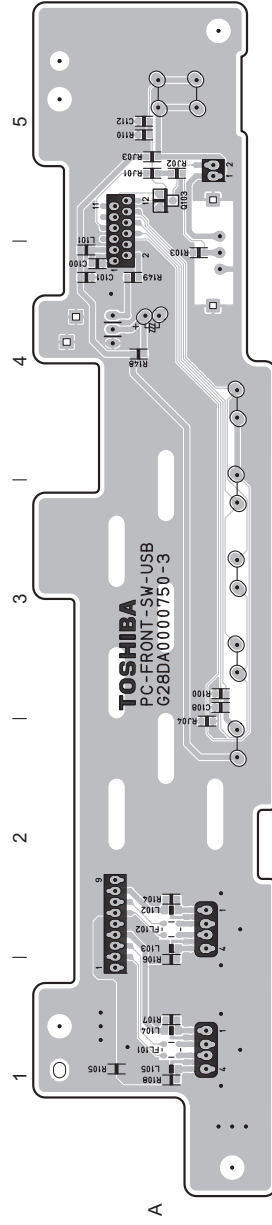

Fig. 3-5-6 Front Switch/USB PC Board (Bottom side)

5-4. ATAPI PC Board

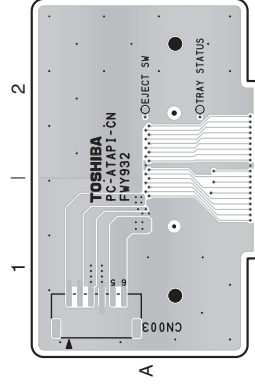

Fig. 3-5-7 ATAPI PC Board (Top side)

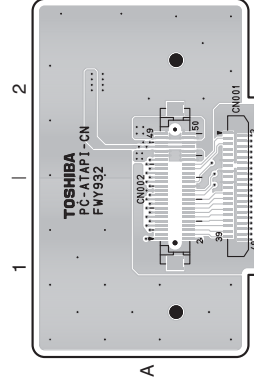

Fig. 3-5-8 ATAPI PC Board (Bottom side)

SECTION 4 PARTS LIST

SAFETY PRECAUTION

The parts identified by ! (Δ) mark are critical for safety. Replace only with part number specified.

The mounting position of replacement is to be identical with originals.

The substitute replacement parts which do not have the same safety characteristics as specified in the parts list may create shock, fire or other hazards.

NOTICE

The part number must be used when ordering parts in order to assist in processing, be sure to include the model number and description.

ABBREVIATIONS

- **Integrated Circuit (IC)**
- **Capacitor (Cap)**
 - **Capacitance Tolerance (for Nominal Capacitance more than 10pF)**

Table 4-1

Symbol	B	C	D	F	G	J	K	M	N
Tolerance %	± 0.1	± 0.25	± 0.5	± 1	± 2	± 5	± 10	± 20	± 30

Symbol	P	Q	T	U	V	W	X	Y	Z
Tolerance %	+100 0	+30 -10	+50 -10	+75 -10	+20 -10	+100 -10	+40 -20	+150 -10	+80 -20

Ex. $10\mu\text{F J} = 10\mu\text{F} \pm 5\%$

- **Capacitance Tolerance (for Nominal Capacitance 10pF or less)**

Table 4-2

Symbol	B	C	D	F	G
Tolerance pF	± 0.1	± 0.25	± 0.5	± 1	± 2

Ex. $10\text{pF G} = 10\text{pF} \pm 2\text{pF}$

- **Resistor (Res)**
 - **Resistance tolerance**

Table 4-3

Symbol	B	C	D	F	G	J	K	M
Tolerance %	± 0.1	± 0.25	± 0.5	± 1	± 2	± 5	± 10	± 20

Ex. $470\Omega\text{J} = 470\Omega \pm 5\%$

1. EXPLODED VIEWS
1-1. Packing Assembly

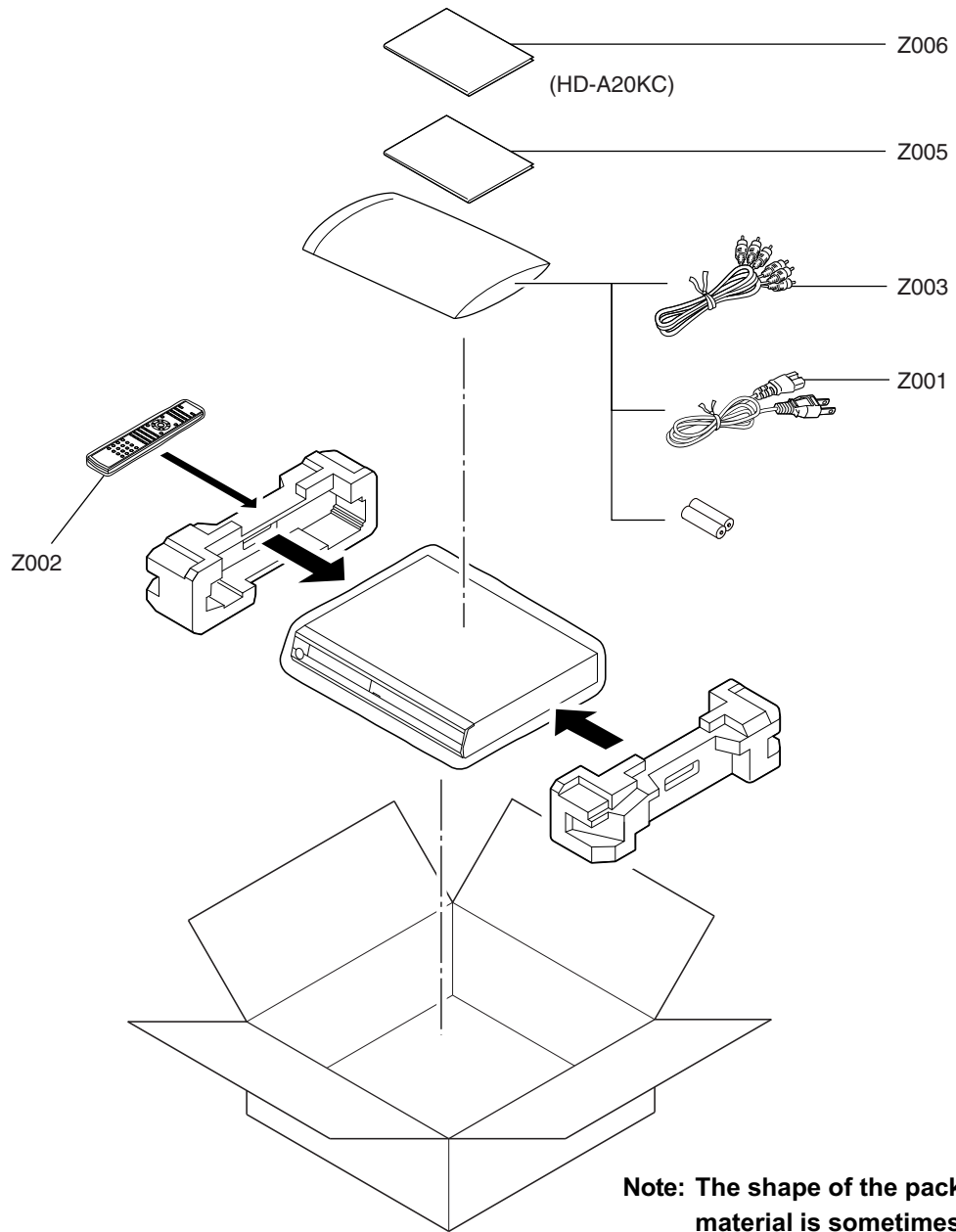

Note: The shape of the packing material is sometimes different.

Fig. 4-1-1

1-2. Chassis Assembly

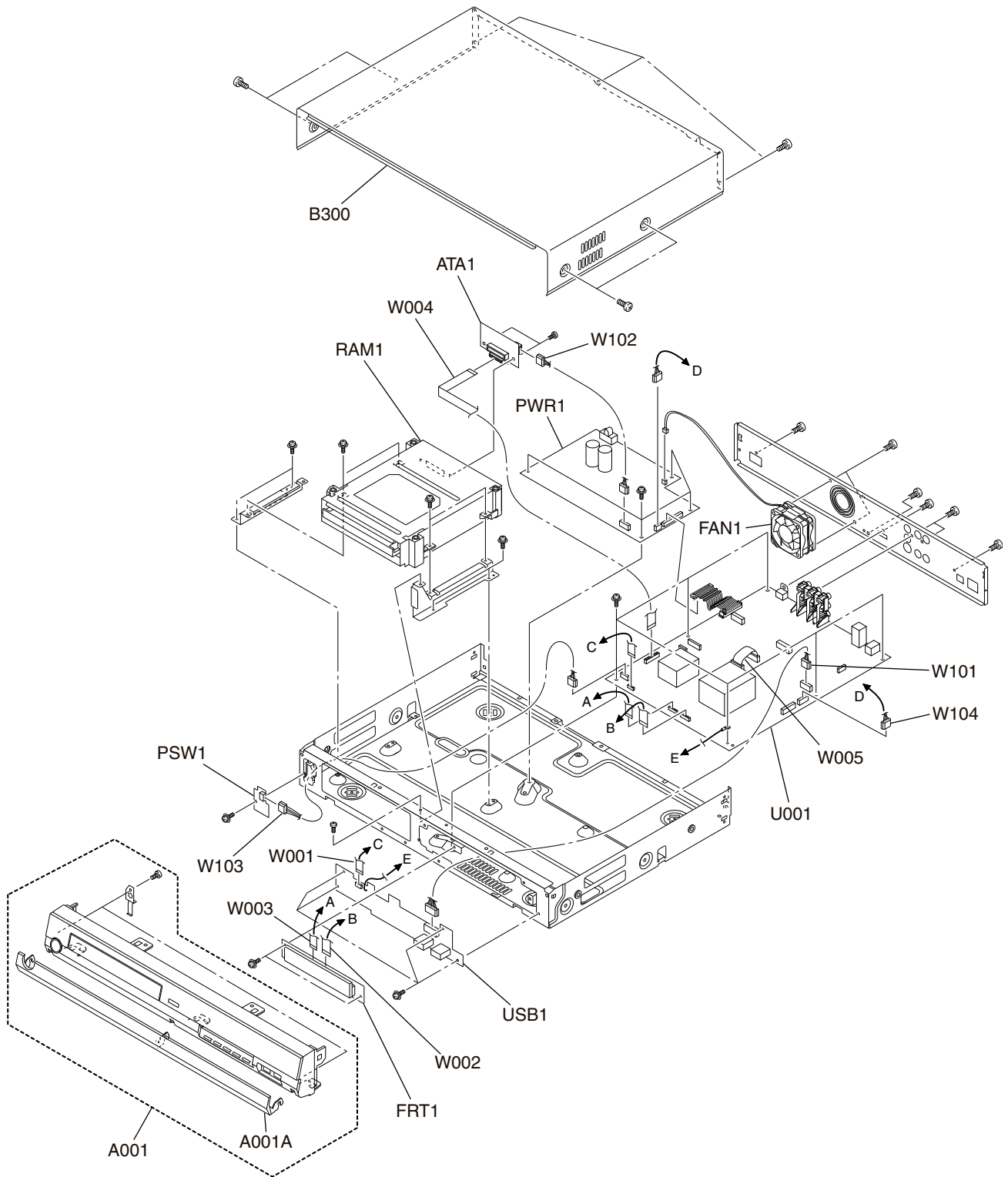

Fig. 4-1-2

2.PARTS LIST

Location No.	Part No.	Description
- ELECTRICAL PARTS -		
U001	P000483030	PC BOARD ASSY, MAIN
		HD-A20KU
U001	P000483080	PC BOARD ASSY, MAIN
		HD-A20KC
⚠ PWR1	P000477370	POWER-UNIT, MPN5236
FRT1	P000483010	PC BOARD ASSY, FRONT-FIP
PSW1	P000483070	PC BOARD ASSY, POWER-SW
USB1	P000483020	PC BOARD ASSY, USB/FRONT-SW
ATA1	P000477350	ATAPI-FFC ADAPTER
- MECHANICAL PARTS -		
A001	P000483050	PANEL ASSY, FRONT
A001A	P000483060	DOOR, FRONT
B300	P000477380	COVER, TOP
FAN1	P000477470	FAN DC, DSB0512LD-6T10
⚠ RAM1	P000477500	HD-DVD-DRIVE, SD-E802A
W001	P000477420	FFC-12P-L110, MAIN-FRONT
W002	P000477430	FFC-20P-L110, MAIN-FRONT
W003	P000477440	FFC-16P-L110, MAIN-FRONT
W004	P000477450	FFC-40P-L250, MAIN-DRIVE
W005	P000483040	FFC-40P-L70, MAIN-FWH
W101	P000477530	WIRE CABLE ZHR-9P-L300, MAIN-USB
W102	P000477540	WIRE CABLE PHR-6P-L100, POWER-ATAPI
W103	P000477550	WIRE CABLE ZHR-4P-L380, MAIN-PWRSW
W104	P000477560	WIRE CABLE PHR-4P-L260, MAIN-POWER
⚠ Z001	P000446040	CORD POWER, AC-US
Z002	P000477490	REMOTE CONTROL, SE-R0252
Z003	P000477520	AV CABLE, 3P-L1500 GR
⚠ Z005	P000480970	OWNERS MANUAL, ENGLISH
		HD-A20KU/KC
⚠ Z006	P000480980	OWNERS MANUAL, FRENCH
		HD-A20KC

SUPPLEMENT

SUPPLEMENT1. Firmware Version Update

We plan to respond to these developments by providing the firmware update.
The latest information will be informed Toshiba customer support on the WEB.

- 1) Main Firmware
- 2) HD DVD Drive Firmware

1. HD DVD Player FW Update

To update the firmware, the following procedures are provided.

1) HD DVD based

Internet connection Direct Download to player

2) CD-ROM

CD-ROM (mail)

2. Check Main Firmware version (in detail)

Check Main FW Version by the special Code from the remote control

<Field Service Use only — Do not disclose to users.>

- 1) Press "ON / STAND BY" on the unit or remote.
- 2) Press "DISPLAY" -> "1"->"9"->"5"-> "DISPLAY"
- 3) FW version is show on TV display as below.

Machine Code: *****
Submicom Version: *****
Group ID: **
Model ID: **
Package Version: 1000
NAND Version: ****
NOR Version: ****
WinCE Version: ****
FWH Version: ****
Drive Version: T20M

3. Firmware Version Check procedure

Check from "SET UP Menu"

- 1) Press "ON / STAND BY" on the unit or remote.
- 2) Press "SETUP" button.
- 3) Select "General" -> "Maintenance"->"Update".
- 4) The firmware version is shown on TV display as below.

Update 1.0/T20M Would you like to continue The update procedure? [Yes] [No]
--

- 5) If select [Yes], downloading update will be started.

4. Firmware Update Procedure

(1) Main (or Drive) FW Update by CD-ROM disc

- 1) Insert Update disc into the unit.
- 2) Indicate the notice.
 - > Select YES & press "OK" button on the remote control.
- 3) Version update is started. Waiting a few minutes.
- 4) Tray will be opened and power off automatically.
- 5) Power On & confirm the FW version.

(2) FW Update from WEB site

From "SETUP" menu, the latest firmware can be downloaded to the unit.

- * Refer to Firmware version check procedure.
- * Internet always-on broadband connection is needed.

SUPPLEMENT2. Error Code

1. System Error

External Error Code								Content of Error	OSD	VFD
1	0	0	0	4	0	0	1	CPU Error		Error Code
2	0	0	0	C	0	0	1	No Disc	No Disc	Error Code
2	0	0	1	C	0	0	2	Disc Detection Error	Cannot play the disc. Check the disc.	Error Code
2	0	0	2	C	0	0	3	Not Support Disc	This disc is not DVD format. Cannot play the disc.	Error Code
2	0	0	3	C	0	0	4	PAL Contents Error	This disc is PAL. Cannot play the disc.	Error Code
2	0	0	4	C	0	0	5	NTSC Error	This disc is NTSC Cannot play the disc.	Error Code
2	0	0	5	C	0	0	6	Region Error	Region error	Error Code
2	0	0	D	C	0	0	7	Parental Error	Cannot play the disc due to parental lock.	Error Code
2	0	0	1	C	0	0	8	Disc Navigation Error	Cannot play the disc. Check the disc.	Error Code
2	0	1	9	C	0	0	9	ICT Warning	High resolution output is prohibited for this content. Resolution was changed to 480p.	Error Code
2	0	2	4	C	0	0	A	ICT Warning	High resolution output is prohibited for this content. Resolution was changed to 480p.	Error Code
2	0	2	5	C	0	0	B	DOT Warning	Analog output is prohibited. Change to HDMI output.	Error Code
2	0	2	2	C	0	0	C	Version Up Confirmation	Version Up ? [[Yes]] No	Error Code
2	0	2	0	C	0	0	D	Latest firmware no version up	The software has already been updated. The update process will end.	Error Code
2	0	1	F	C	0	0	E	Start Version Up Procedure	Updating. Do not turn off.	Error Code
2	0	0	7	C	0	0	F	Version Up Error	Error Code : 0xXXXXXXXX	Error Code
2	0	0	7	C	0	1	0	Version Up Error	Error Code : 0xXXXXXXXX	Error Code
2	0	0	E	C	0	1	1	AACS Error	The prohibited transaction was executed by the content.	Error Code
2	0	0	F	C	0	1	2	AACS Error	This disc is not available for this player.	Error Code
2	0	1	0	C	0	1	3	AACS Error	Playback is prohibited. The playback is stopped.	Error Code
2	0	1	1	C	0	1	4	AACS Error	Failed to verify the content. The playback is stopped.	Error Code
2	0	1	2	C	0	1	5	AACS Error	Management system error occurred. Please call Toshiba Customer Support.	Error Code
2	0	1	3	C	0	1	6	AACS Error	System error occurred.	Error Code
2	0	*	*	C	0	1	7	AACS Error	Cannot play the disc. Error code : 0x00000000	Error Code
2	0	*	*	C	0	1	8	AACS Error	Cannot play the disc. Error code : 0x00000000	Error Code
2	0	*	*	C	0	1	9	Initialization Error	Cannot play the disc. Error code : 0x00000000	Error Code
2	0	*	*	C	0	1	A	Celeron CPU Interconnection Error	Cannot play the disc. Error code : 0x00000000	Error Code
2	0	*	*	C	0	1	B	File creation error	Cannot play the disc. Error code : 0x00000000	Error Code
2	0	*	*	C	0	1	C	internal error	Cannot play the disc. Error code : 0x00000000	Error Code
2	0	*	*	C	0	1	D	DISCID.DAT,Playlist Error	Cannot play the disc.	Error Code
2	0	*	*	C	0	1	E	internal error	Cannot play the disc. Error code : 0x00000000	Error Code
2	0	*	*	C	0	1	F	advanced error	Cannot play the disc. Error code : 0x00000000	Error Code
4	0	*	*	C	5	0	1	Disc unreadable error	Cannot play the disc. Check the disc.	Error Code
4	0	*	*	C	5	0	2	50Hz HD DVD warning	Cannot play the disc.	Error Code
4	0	*	*	C	5	0	3	AACS Error		Error Code
4	0	*	*	C	5	0	4	Contents Error	Cannot play the disc. Error code : 0x00000000	Error Code
4	0	*	*	C	5	0	5	No File	Cannot play the disc. Error code : 0x00000000	Error Code
4	0	*	*	C	5	1	6	AACS Error	Failed to verify the content. The playback is stopped.	Error Code
4	0	*	*	C	5	1	A	AACS Error	System error occurred.	Error Code
4	0	*	*	C	5	F	E	unexpected error	Cannot play the disc. Error code : 0x00000000	Error Code

External Error Code								Content of Error	OSD	VFD
4	0	*	*	C	8	1	3	AACS Error	The prohibited transaction was executed by the content.	Error Code
4	0	*	*	C	8	1	4	AACS Error	This disc is not available for this player.	Error Code
4	0	*	*	C	8	1	5	AACS Error	Playback is prohibited. The playback is stopped.	Error Code
4	0	*	*	C	8	1	6	AACS Error	Failed to verify the content. The playback is stopped.	Error Code
4	0	*	*	C	8	1	7	AACS Error	Management system error occurred. Please call Toshiba Customer Support.	Error Code
4	0	*	*	C	8	1	A	AACS Error	System error occurred.	Error Code
4	0	*	*	C	0	0	3	Contents Error	Cannot play the disc. Error code : 0x00000000	Error Code
4	0	*	*	C	0	0	4	System Error	Cannot play the disc. Error code : 0x00000000	Error Code
4	0	*	*	C	0	0	8	Secure Access Controller Failure	Cannot play the disc. Error code : 0x00000000	Error Code
4	0	*	*	C	0	0	B	Resource Load Failure	Cannot play the disc. Error code : 0x00000000	Error Code
4	0	*	*	C	0	0	C	Script Failure	Cannot play the disc. Error code : 0x00000000	Error Code
4	0	*	*	C	0	0	D	Markup Error	Cannot play the disc. Error code : 0x00000000	Error Code
4	0	*	*	C	2	0	3	Playlist Error	Cannot play the disc. Error code : 0x00000000	Error Code
4	0	*	*	4	6	0	0	Graphics critical Error	Cannot play the disc. Error code : 0x00000000	Error Code
4	0	*	*	4	6	0	1	Pixel Buffer Error	Cannot play the disc. Error code : 0x00000000	Error Code
4	0	*	*	4	6	0	3	Unexpected Error	Cannot play the disc. Error code : 0x00000000	Error Code
4	0	8	B	C	7	0	0	Network API Error	Cannot play the disc. Error code : 0x00000000	Error Code
4	0	8	B	C	7	0	1	DISCID.DAT Error	Cannot play the disc. Error code : 0x00000000	Error Code
4	0	8	B	C	7	1	0	Illegal Input File	Cannot play the disc. Error code : 0x00000000	Error Code
4	0	8	B	C	7	1	1	AACS Initialize Error	Cannot play the disc. Error code : 0x00000000	Error Code
4	0	8	B	C	7	1	3	Illegal AACS call	Cannot play the disc. Error code : 0x00000000	Error Code
4	0	8	B	C	7	1	A	System Error	Cannot play the disc. Error code : 0x00000000	Error Code
4	0	8	B	C	7	F	E	Network API Critical Error	Cannot play the disc. Error code : 0x00000000	Error Code

*OSD is a display of the TV monitor screen.

*VFD is a display of the indicator of the front panel

2. Update Error

Error Code								Contents of Error	Remark
2	0	*	*	C	5	0	1	Decryption Error	
2	0	*	*	C	5	0	2	Decryption Error	
2	0	*	*	C	5	0	8	Same Version	
2	0	*	*	C	5	1	0	file read error	
2	0	*	*	C	5	1	1	file read error	
2	0	*	*	C	5	1	8	Memory Error	
2	0	*	*	C	5	1	9	Memory Error	
2	0	*	*	C	5	2	1	File Error	
2	0	*	*	C	5	2	2	Network Error	Wrong Network Setting
2	0	*	*	C	5	2	3	Proxy Error	Wrong Network Setting
2	0	*	*	C	5	2	4	Proxy Error	Wrong Network Setting
2	0	*	*	C	5	2	5	Proxy Error	LAN connection error
2	0	*	*	C	5	2	6	connect error	
2	0	*	*	C	5	2	7	connect error	
2	0	*	*	C	5	2	8	server error	line busy
2	0	*	*	C	5	2	9	server error	line busy
2	0	*	*	C	5	2	A	server error	line busy
2	0	*	*	C	5	2	B	SSL error	
2	0	*	*	C	5	2	C	SSL error	
2	0	*	*	C	5	2	D	SSL error	
2	0	*	*	C	5	2	E	SSL error	
2	0	*	*	C	5	2	F	SSL error	
2	0	*	*	C	5	3	0	SSL error	
2	0	*	*	C	5	3	1	SSL error	
2	0	*	*	C	5	3	2	SSL error	
2	0	*	*	C	5	3	3	CRL error	
2	0	*	*	C	5	3	4	verification error	
2	0	*	*	C	5	3	5	CRL error	
2	0	*	*	C	5	3	6	CRL error	
2	0	*	*	C	5	3	7	CRL error	
2	0	*	*	C	5	3	8	CRL error	
2	0	*	*	C	5	3	9	verification error	
2	0	*	*	C	5	3	A	verification error	
2	0	*	*	C	5	3	B	verification error	
2	0	*	*	C	5	3	C	verification error	
2	0	*	*	C	5	3	D	verification error	
2	0	*	*	C	5	3	E	verification error	
2	0	*	*	C	5	3	F	verification error	
2	0	*	*	C	5	4	0	verification error	clock setting
2	0	*	*	C	5	4	1	verification error	
2	0	*	*	C	5	4	2	verification error	
2	0	*	*	C	5	4	3	verification error	
2	0	*	*	C	5	4	4	Application Error	
2	0	*	*	C	5	4	5	Memory Error	
2	0	*	*	C	5	4	6	verification error	
2	0	*	*	C	5	4	7	verification error	
2	0	*	*	C	5	4	8	verification error	
2	0	*	*	C	5	4	9	verification error	
2	0	*	*	C	5	4	A	authority and subject key identifier mismatch	
2	0	*	*	C	5	4	B	not match serial number	
2	0	*	*	C	5	4	C	verification error	
2	0	*	*	C	5	4	D	not valid time	clock setting

Error Code								Contents of Error	Remark
2	0	*	*	C	5	4	E	not valid time	clock setting
2	0	*	*	C	5	4	F	long path name	
2	0	*	*	C	5	5	0	verification error	
2	0	*	*	C	5	5	1	server error	line busy
2	0	*	*	C	5	5	2	server error	line busy
2	0	*	*	C	5	5	3	server error	line busy
2	0	*	*	C	5	5	4	SSL error	
2	0	*	*	C	5	5	5	data size error	
2	0	*	*	C	5	5	6	data size error	
2	0	*	*	C	5	7	0	Drive Error	
2	0	*	*	C	5	7	1	Drive manufacturer Error	
2	0	*	*	C	5	7	2	Drive Error	
2	0	*	*	C	5	7	3	Drive Error	
2	0	*	*	C	5	9	0	Drive Error	
2	0	*	*	C	5	9	1	flash memory error	
2	0	*	*	C	5	9	2	flash memory error	
2	0	*	*	C	5	9	3	flash memory error	
2	0	*	*	C	5	9	8	flash memory error	
2	0	*	*	C	5	9	9	flash memory error	
2	0	*	*	C	5	9	A	flash memory error	
2	0	*	*	C	5	A	0	flash memory error	VR NAND
2	0	*	*	C	5	A	1	flash memory error	VR NAND
2	0	*	*	C	5	A	2	flash memory error	VR NAND
2	0	*	*	C	5	A	3	Memory Error	memory shortage
2	0	*	*	C	5	A	4	Memory Error	memory shortage
2	0	*	*	C	5	A	5	Memory Error	memory shortage
2	0	*	*	C	5	A	6	flash memory error	VR NAND
2	0	*	*	C	5	A	7	flash memory error	VR NAND
2	0	*	*	C	5	A	8	flash memory error	VR NAND
2	0	*	*	C	5	A	9	flash memory error	VR NAND
2	0	*	*	C	5	A	A	flash memory error	VR NAND
2	0	*	*	C	5	A	B	flash memory error	VR NAND
2	0	*	*	C	5	A	C	flash memory error	VR NAND
2	0	*	*	C	5	A	D	flash memory error	VR NAND
2	0	*	*	C	5	A	E	flash memory error	VR NAND
2	0	*	*	C	5	C	0	machine code error	
2	0	*	*	C	5	C	1	hardware type unmatched	
2	0	*	*	C	5	C	2	hardware type unmatched	
2	0	*	*	C	5	C	3	same version	
2	0	*	*	C	5	D	8	not good version up image	
2	0	*	*	C	5	D	9	memory write error	
2	0	*	*	C	5	D	A	memory write error	
2	0	*	*	C	5	D	B	memory write error	
2	0	*	*	C	5	E	0	Drive firmware version up error	
2	0	*	*	C	5	E	1	internal command error	
2	0	*	*	C	5	E	2	internal command error	
2	0	*	*	C	5	E	3	internal command error	
2	0	*	*	C	5	E	4	internal command error	
2	0	*	*	C	5	F	1	internal command error	
2	0	*	*	C	5	F	2	internal command error	

SUPPLEMENT3. TROUBLESHOOTING

3-1. Standby LED (red) does not light.

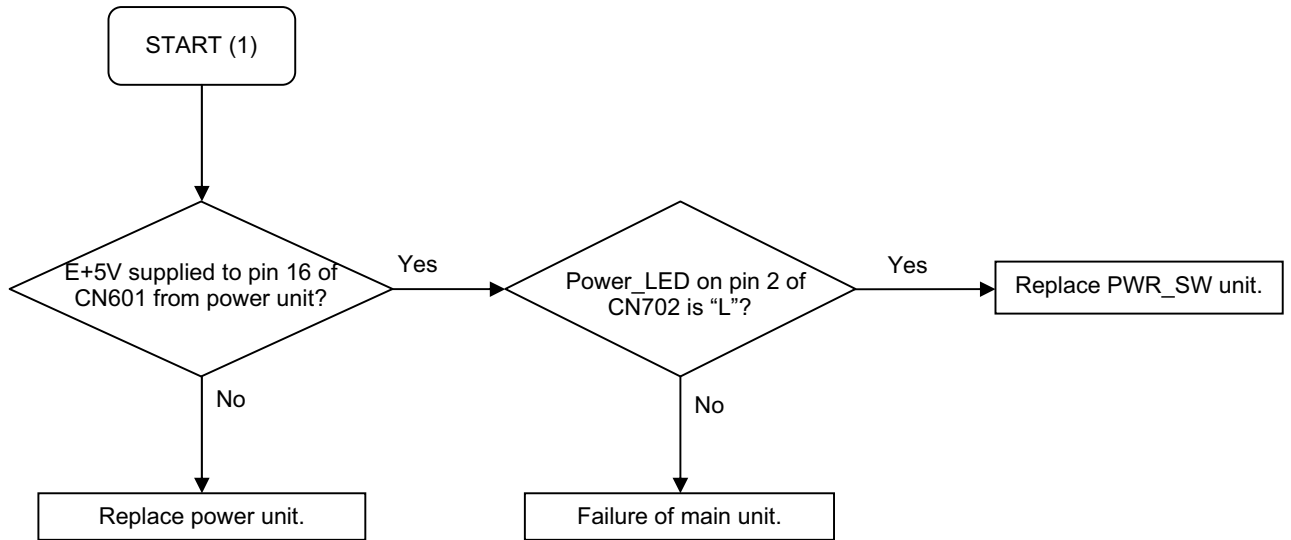

3-2. LED (green) does not light at power on.

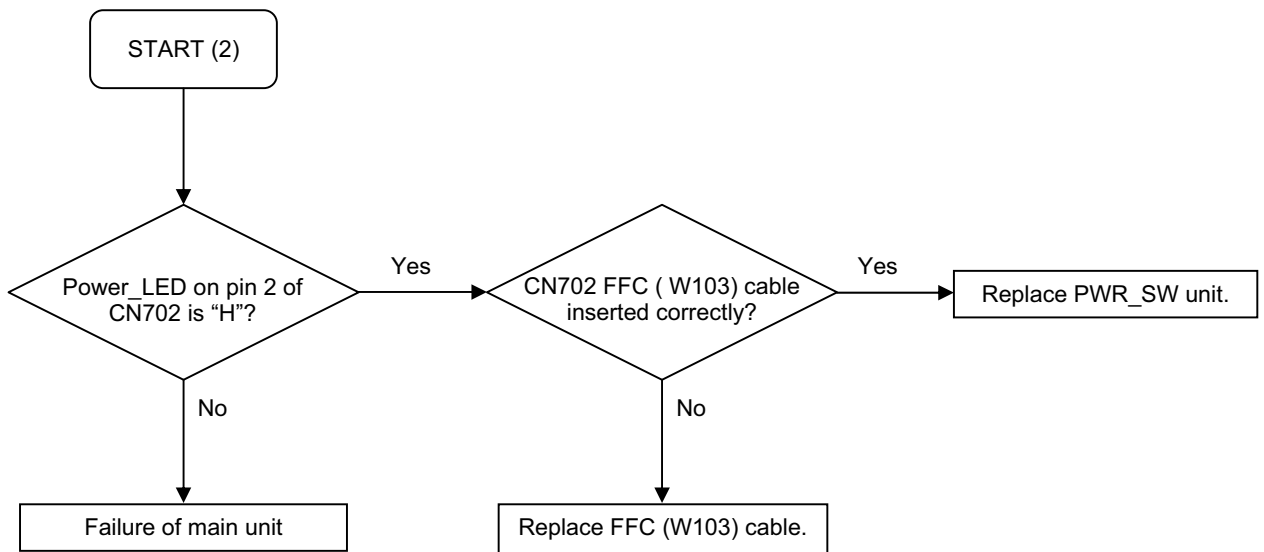

3-3. CPU FAN does not work.

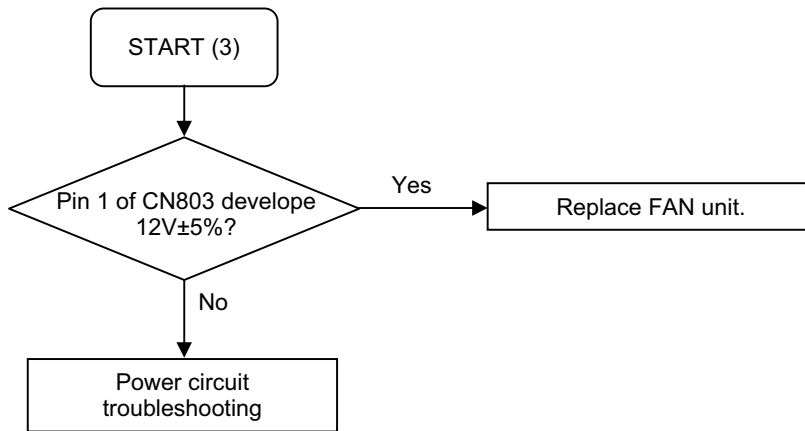

3-4. Indicator does not light. ("WELCOME" does not light at startup.)

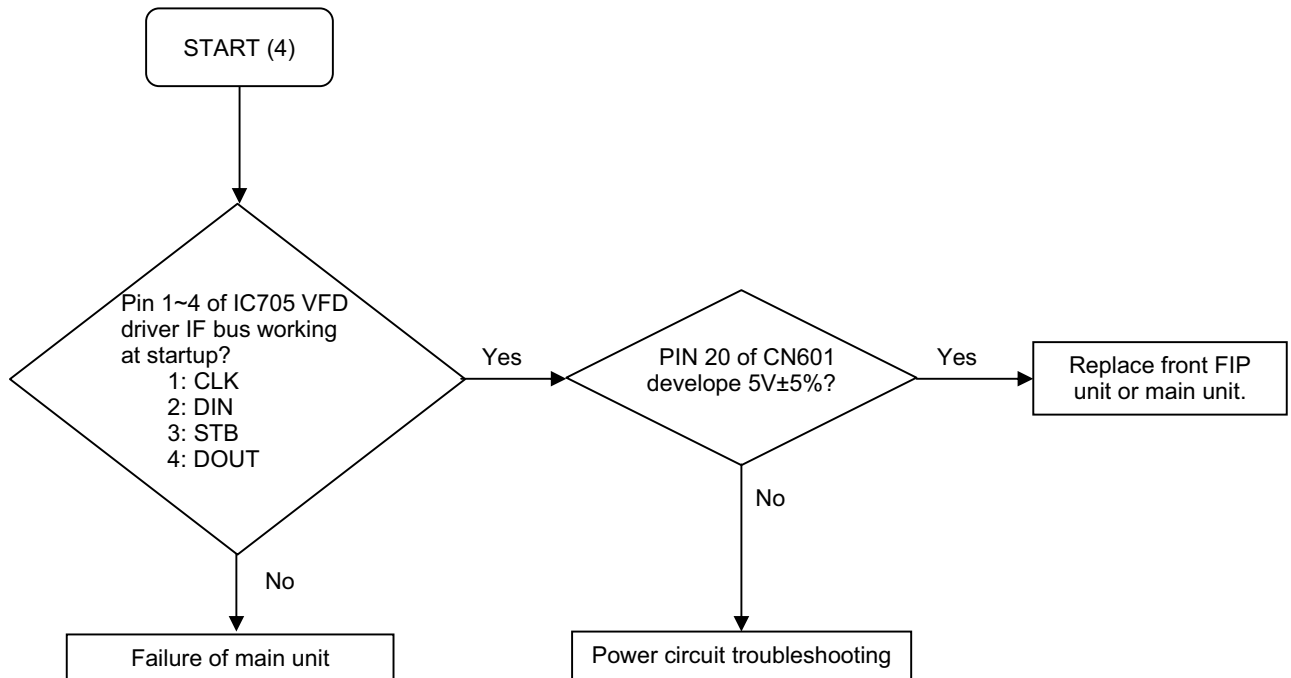

3-5. System does not run. ("WELCOME" displayed and key operation disabled)

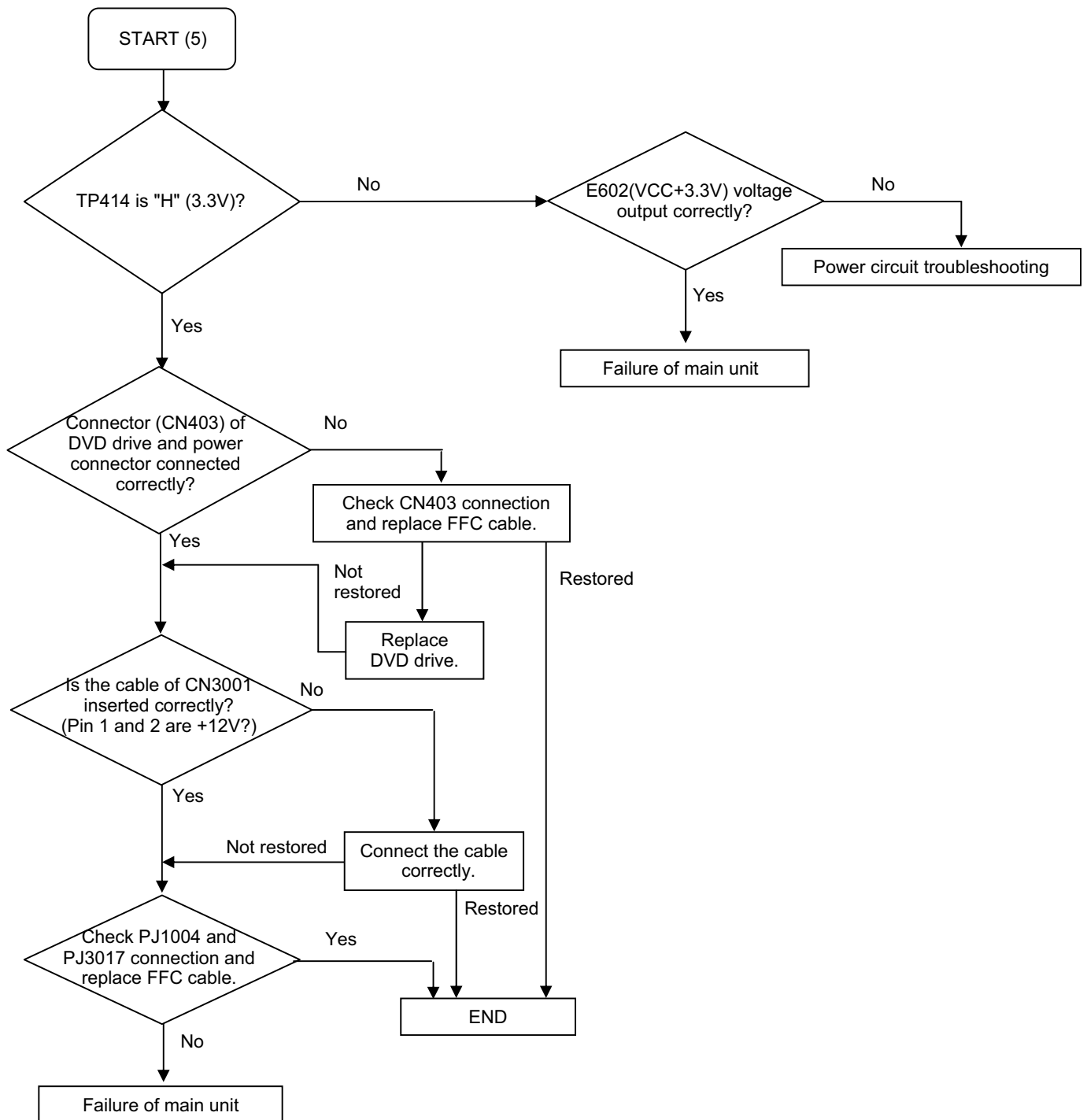

3-6. No picture appears.

- Before repair, confirm the connection with a TV set and the settings of DVD player.

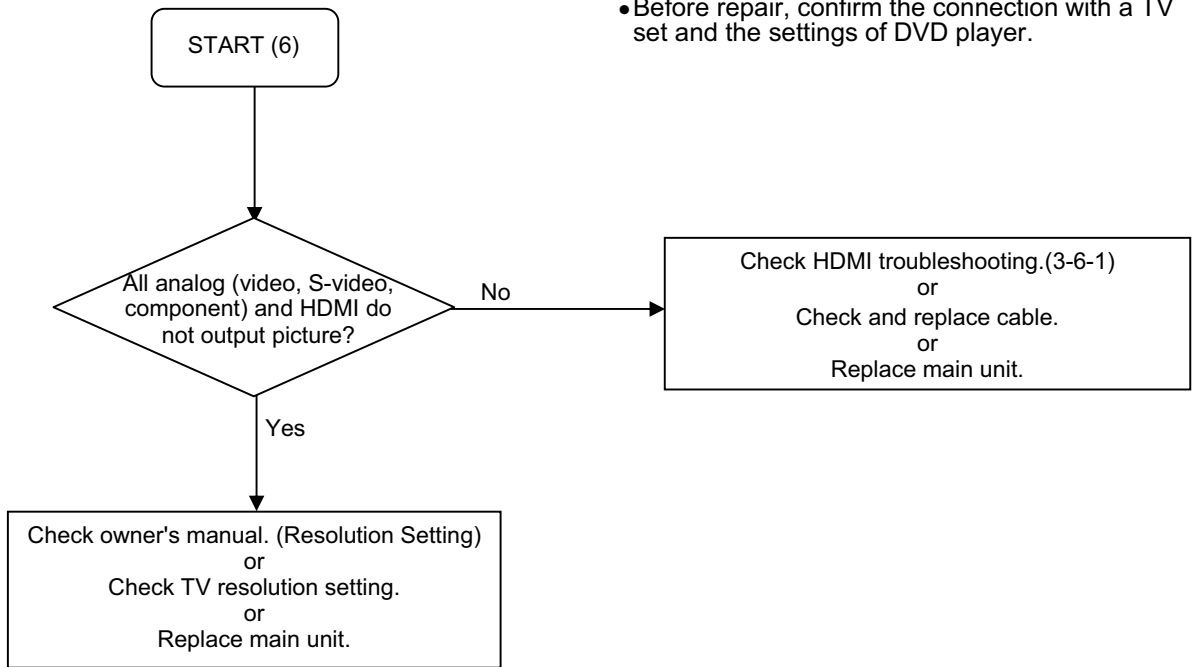

3-6-1. No output from HDMI.

- Replace main unit.

3-7. No audio is played back.

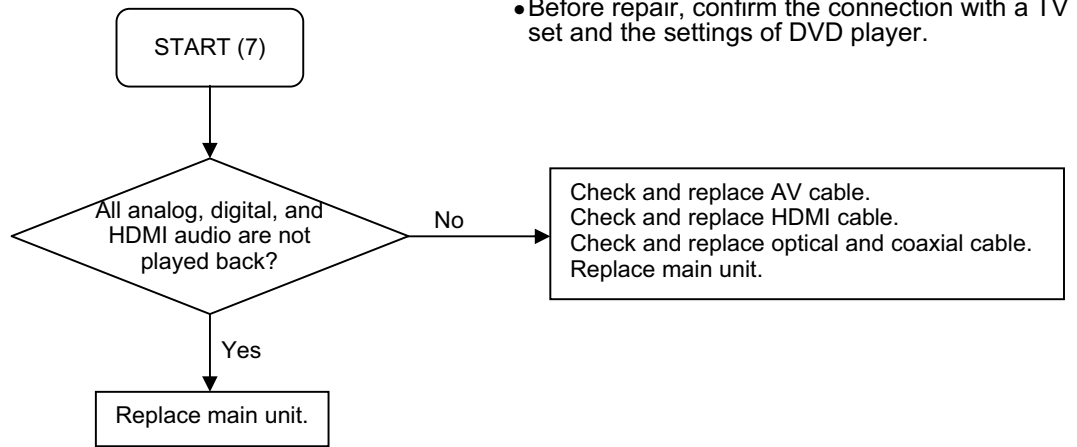

3-8. Buzzer does not sound.

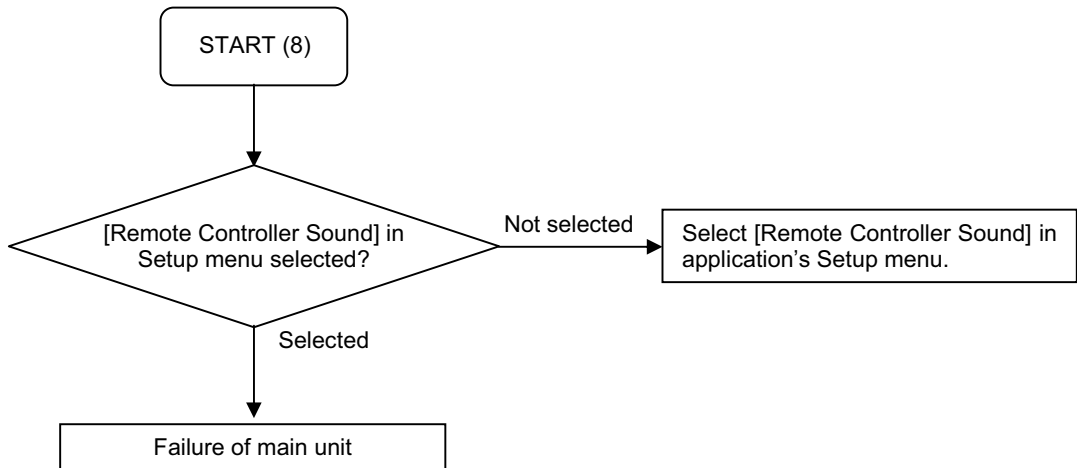

3-9. Extension port does not work.

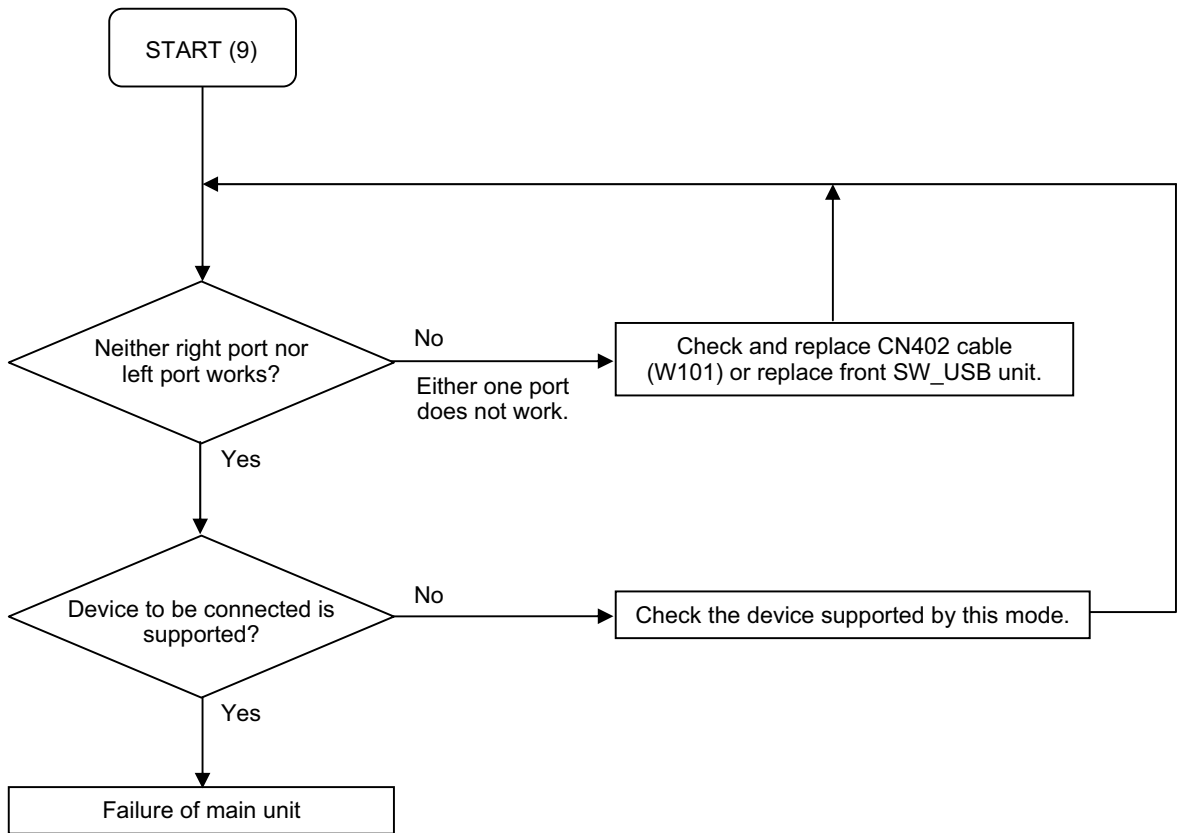

3-10. Front panel keys/remote control are disabled.

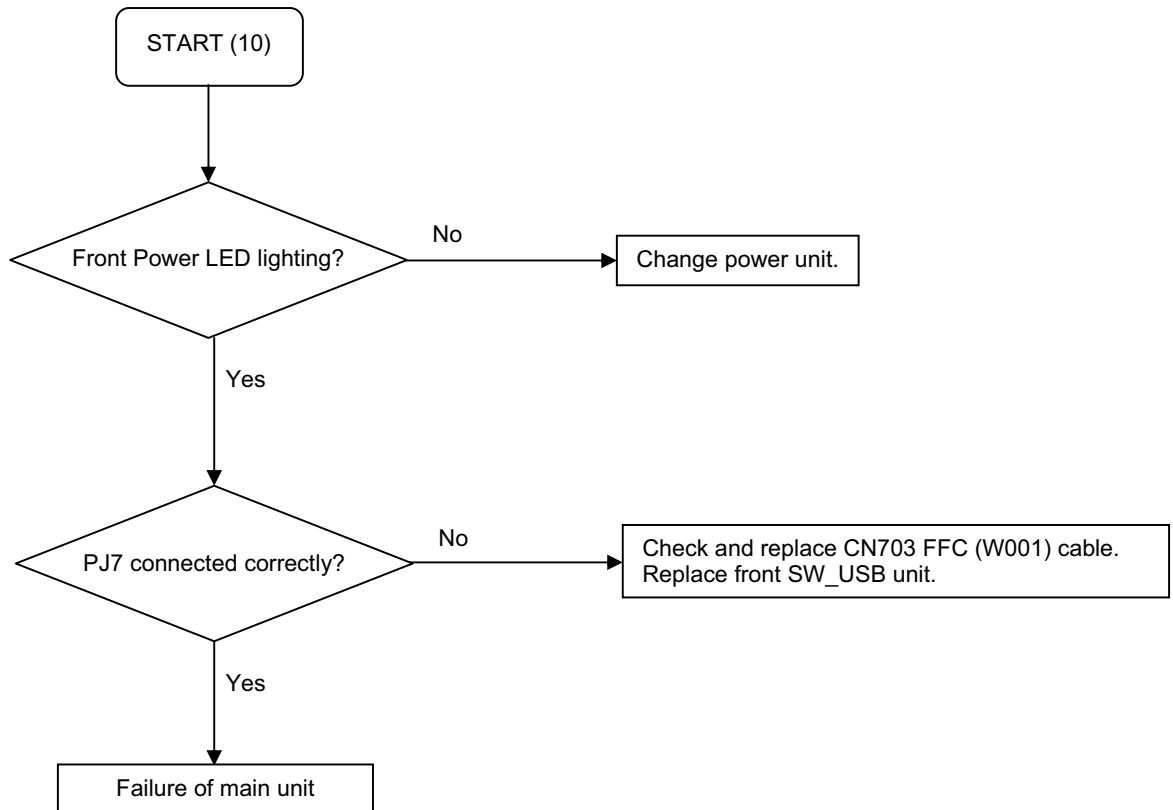

3-11. Other Symptoms

- Improper LAN connection
LAN depends on the quality of the environment and lines to which LAN is connected. Check the DVD player as well as network settings, cables, and connected devices.
- Improper CONTROL pin connection
Use a serial cross cable to connect the unit to a PC.

Check the above. However, if the problem still remains, the main unit may be faulty.

3-12. Power Circuit Troubleshooting

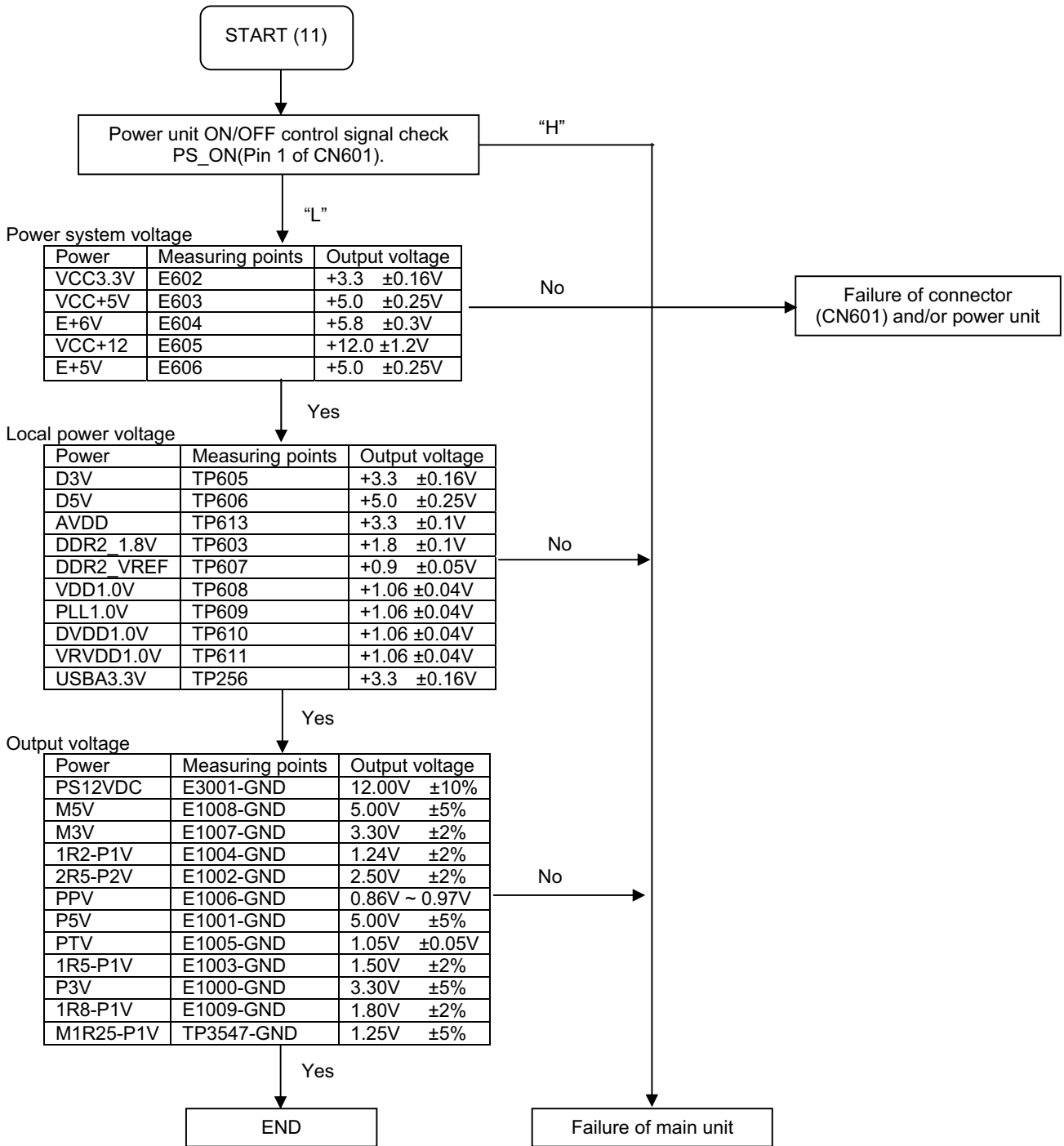

SPECIFICATIONS

Power requirement	36.0W
Power supply	120V AC 60Hz
Mass	4.1kg
External dimension	Width 430 x Height 65.5 x Depth 343mm
Signal system	Standard NTSC Color TV system
Laser	Semiconductor laser, Wavelength: 405nm/650nm/780nm
VIDEO output	1.0Vp-p (75Ω), Sync signal negative, Pin jack x 1 system
S-VIDEO output	(Y) 1.0Vp-p (75Ω), Sync signal negative, (C) 0.286Vp-p (75Ω), 1 at rear Mini DIN4 Pin x 1 system
COMPONENT output (Y, P _B , P _R)	Y output (green), 1.0Vp-p (75Ω), Sync signal negative, Pin jack x 1 system P _B , P _R output (blue, red), 0.7Vp-p (75Ω), Pin jack x 1 system each
ANALOG AUDIO output	2.0V (rms), 2.2kΩ or below, pin jack (L, R) x 1 system
DIGITAL AUDIO OUTPUT (BITSTREAM/PCM jack)	Optical connector x 1 system
LAN port	100BASE-TX/10BASE-T x 1
EXTENSION port	EXTENSION port x 2 systems
HDMI output	19 pin
Remote control	Wireless remote control (SE-R0252)
Operating conditions	Temperature: 41°F ~ 95°F (5°C ~ 35°C), Position: Horizontal
Clock accuracy	Quartz (monthly deviation: approximately ±30 seconds)

- This model complies with the above specifications.
- Designs and specifications are subject to change without notice.
- This model may not be compatible with features and/or specifications that may be added in the future.
- The illustrations and screens described in this manual may be exaggerated or simplified for easy recognition and may be slightly different from the actual unit.

TOSHIBA CORPORATION

1-1, SHIBAURA 1-CHOME, MINATO-KU, TOKYO 105-8001, JAPAN