

# TOSHIBA

FILE NO. 810-200691GR

Rev.01

## SERVICE MANUAL



## HD DVD PLAYER

# HD-E1KE



The above models are classified as green products (\*1), as indicated by the underlined serial numbers.  
This Service Manual describes replacement parts for the green products. When repairing these green product(s), use the part(s) described in this manual and lead-free solder (\*2).

For (\*1) and (\*2), see the next page.

Dec., 2006 GREEN

(\*1)

## GREEN PRODUCT PROCUREMENT

The EC is actively promoting the WEEE & RoHS Directives that define standards for recycling and reuse of Waste Electrical and Electronic Equipment and for the Restriction of the use of certain Hazardous Substances. From July 1, 2006, the RoHS Directive will prohibit any marketing of new products containing the restricted substances.

Increasing attention is given to issues related to the global environmental. Toshiba Corporation recognizes environmental protection as a key management tasks, and is doing its utmost to enhance and improve the quality and scope of its environmental activities. In line with this, Toshiba proactively promotes Green Procurement, and seeks to purchase and use products, parts and materials that have low environmental impacts.

Green procurement of parts is not only confined to manufacture. The same green parts used in manufacture must also be used as replacement parts.

(\*2)

## LEAD-FREE SOLDER

This product is manufactured using lead-free solder as a part of a movement within the consumer products industry at large to be environmentally responsible. Lead-free solder must be used in the servicing and repair of this product.

### **WARNING**

**This product is manufactured using lead free solder.**

### **DO NOT USE LEAD BASED SOLDER TO REPAIR THIS PRODUCT !**

The melting temperature of lead-free solder is higher than that of leaded solder by 86°F to 104°F (30°C to 40°C). Use of a soldering iron designed for lead-based solders to repair product made with lead-free solder may result in damage to the component and or PCB being soldered. Great care should be made to ensure high-quality soldering when servicing this product especially when soldering large components, through-hole pins, and on PCBs as the level of heat required to melt lead-free solder is high.

## SAFETY INSTRUCTIONS

**WARNING:** BEFORE SERVICING THIS CHASSIS, READ THE " SAFETY PRECAUTION " AND " PRODUCT SAFETY NOTICE " INSTRUCTIONS BELOW.

### SAFETY PRECAUTION

**WARNING:** SERVICE SHOULD NOT BE ATTEMPTED BY ANYONE UNFAMILIAR WITH THE NECESSARY PRECAUTIONS ON THIS RECEIVER. THE FOLLOWING ARE THE NECESSARY PRECAUTIONS TO BE OBSERVED BEFORE SERVICING THIS CHASSIS.

- An isolation transformer should be connected in the power line between the receiver and the AC line before any service is performed on the receiver.
- When replacing a chassis in the cabinet, always be certain that all the protective devices are put back in place, such as; nonmetallic control knobs, insulating covers, shields, isolation resistor-capacitor network etc.
- Always advise users to keep children away. There is danger of injury to children from tools, disassembled products, etc.
- Always disconnect the power plug before starting work whenever power is not required. Failure to disconnect the power plug before starting work can result in electrical shock.
- Depending on the model, use an insulation transformer or wear gloves when servicing with the power on, and disconnect the power plug to avoid electrical shock when replacing parts. In some cases, alternating current is also impressed in the chassis, so electrical shock is possible if the chassis is contacted with the power on.
- Always use the replacement parts specified for the particular model when making repairs. The parts used in products have the necessary safety characteristics such as inflammability, voltage resistance, etc. ; therefore, use only replacement parts that have these same characteristics. Use only the  specified parts when the mark is include in a circuit diagram or parts list.
- Parts mounting and routing of the wiring should be the same as that used originally. For safety purposes, insulating materials such as tubing or tape is sometimes used and printed circuit boards are sometimes mounted floating. Also make sure that wiring is routed and clamped to avoid parts that generate heat and which use high voltage. Always follow the original scheme.
- After a repair has been completed, reassemble all disassembled pars, and route and reconnect the wiring, in accordance with the original scheme. Do not allow internal wiring to be pinched by cabinets, panels, etc. Any error in reassembly or wiring can result in electrical leakage, flame, etc.,and may be hazardous.
- Never remodel the product in any way. Remodeling can result in improper operation, malfunction, or electrical leakage and flame, which may be hazardous.

## Touch current check

(After completing the work, measure touch current to prevent an electric shock.)

- Plug the AC cord directly into the AC outlet. Do not use an isolation transformer for this check..
- Connect a measuring network for touch currents between each exposed metallic part on the set and a good earth ground such as a water pipe, as shown in Figure D.1
- The potential at any point(TOUCH CURRENT) expressed as voltage  $U_1$  and  $U_2$  does not exceed the following value:

The part or contact of a TERMINAL is not HAZARDOUS LIVE if:

a) the open-circuit voltage does not exceed 35 V (peak) a.c. or 60 V d.c.,

or, if a) is not met,

b) the measurement of the TOUCH-CURRENT shall be carried out in accordance with IEC 60990, with the measuring network described in annex D of this standard.

The TOUCH CURRENT expressed as voltages  $U_1$  and  $U_2$ , does not exceed the following values:

- for a.c.:  $U_1 = 35$  V (peak) and  $U_2 = 0.35$  V (peak);

- for d.c.:  $U_1 = 1,0$  V,

NOTE 5 -The limit values of  $U_2 = 0.35$  V (peak) for a.c. and  $U_1 = 1.0$  V for d.c. correspond, to the values 0,7mA (peak) a.c. and 2,0 mA 2,0mA d.c.

The limit value  $U_1 = 35$  V (peak) for a.c. corresponds to the value 70mA (peak) a.c. for frequencies greater than 100 kHz.

Annex D  
(normative)  
Measuring network for TOUCH CURRENTS

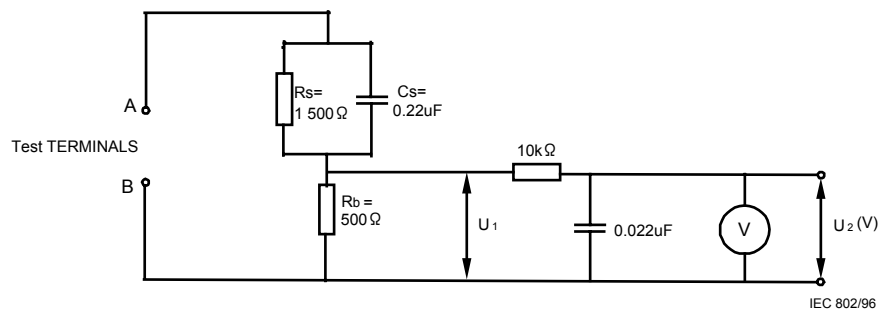

Resistance values in ohms( $\Omega$ )

V: Voltmeter or oscilloscope  
(r.m.s or peak reading)

Input resistance:  $\geq 1$  M $\Omega$

Input capacitance:  $\leq 200$  pF

Frequency range: 15 Hz to 1 MHz and d.c. respectively

NOTE-Appropriate measures should be taken to obtain the correct value in case of non-sinusoidal waveforms.

The measuring instrument is calibrated by comparing the frequency factor of  $U_2$  with the solid line in figure F.2 of IEC 60990 at various frequencies. A calibration curve is constructed showing the deviation of  $U_2$  from the ideal curve as a function of frequency.

TOUCH CURRENT =  $U_2 / 500$  (peak value)

Fig.D.1

## PRODUCT SAFETY NOTICE

Many electrical and mechanical parts in this chassis have special safety-related characteristics. These characteristics are often passed unnoticed by a visual inspection and the protection afforded by them cannot necessarily be obtained by using replacement components rated for higher voltage, wattage, etc. Replacement parts which have these special safety characteristics are identified in this manual and its supplements; electrical components having such features are identified by the international hazard symbols on the schematic diagram and the parts list. Before replacing any of these components, read the parts list in this manual carefully. The use of substitute replacement parts which do not have the same safety characteristics as specified in the parts list may create shock, fire, or other hazards.



The lightning flash with arrowhead symbol, within an equilateral triangle, is intended to alert the user to the presence of uninsulated “ dangerous voltage ” within the products enclosure that may be of sufficient magnitude to constitute a risk of electric shock to persons.



The exclamation point within an equilateral triangle is intended to alert the user to the presence of important operating and maintenance (servicing) instructions in the literature accompanying the appliance.

## LASER BEAM CAUTION LABEL



When the power supply is being turned on, you may not remove this laser cautions label. If it removes, radiation of a laser may be received.

## PREPARATION OF SERVICING

Pickup Head consists of a laser diode that is very susceptible to external static electricity.

Although it operates properly after replacement, if it was subject to electrostatic discharge during replacement, its life might be shortened. When replacing, use a conductive mat, soldering iron with ground wire, etc. to protect the laser diode from damage by static electricity.

And also, the LSI and IC are same as above.

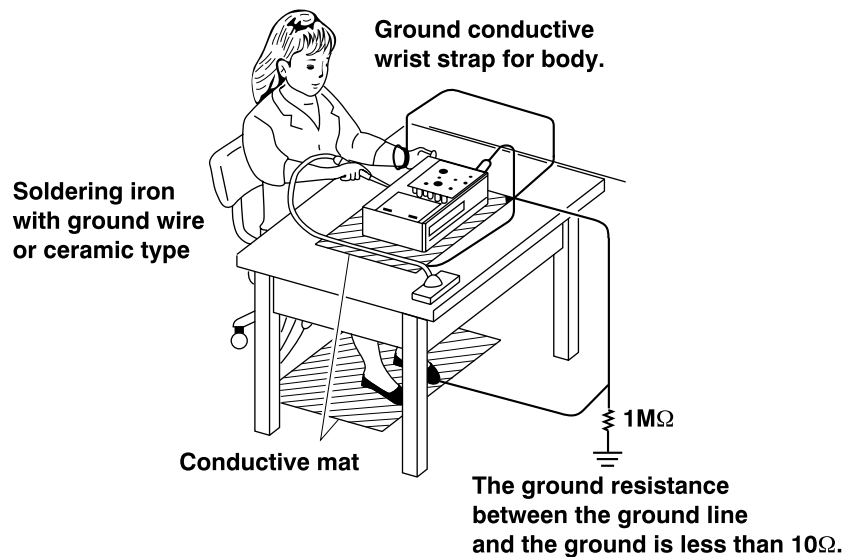

- Dolby features manufactured under license from Dolby Laboratories. Dolby and the double-D symbol are trademarks of Dolby Laboratories.
- DTS features manufactured under license from Digital Theater Systems, Inc. U.S. Pat. No's. 5,451,942; 5,956,674; 5,974,380; 5,978,762; 6,226,616; 6,487,535 and other U.S. and world-wide patents issued and pending. "DTS" and "DTS Digital Surround" are registered trademarks of Digital Theater Systems, Inc.  
Copyright 1996, 2003 Digital Theater Systems, Inc. All Rights Reserved.
- HDMI, the HDMI logo and High-Definition Multimedia Interface are trademarks or registered trademarks of HDMI Licensing LLC.
- SHARC is a registered trademark and Melody is a trademark of Analog Devices, Inc.
- All other brand and product names mentioned in this manual are trademarks and/or registered trademarks of their respective holders.

# CONTENTS

## SECTION 1 GENERAL DESCRIPTIONS

1. OPERATING INSTRUCTIONS
  2. LOCATION OF MAIN PARTS
    - 2-1. Location of Main Parts
    - 2-2. Location of PC Boards
- 

## SECTION 2 PART REPLACEMENT PROCEDURES

1. REPLACEMENT OF MECHANICAL PARTS
    - 1-1. Front Panel, Front PC Boards
    - 1-2. Main/Power PC Boards
    - 1-3. DVD Drive
  2. WIRING CONNECTION DIAGRAM
- 

## SECTION 3 SERVICING DIAGRAMS

1. CIRCUIT SYMBOLS AND SUPPLEMENTARY EXPLANATION
    - 1-1. Precautions for Part Replacement
    - 1-2. Solid Resistor Indication
    - 1-3. Capacitance Indication
    - 1-4. Inductor Indication
    - 1-5. Waveform and Voltage Measurement
    - 1-6. Others
  2. PRINTED WIRING BOARD AND SCHEMATIC DIAGRAM
  3. BLOCK DIAGRAMS
  4. CIRCUIT DIAGRAMS
    - 4-1. Power Supply Circuit Diagram
    - 4-2. Front Circuit Diagram
      - 4-2-1. Front FIP Circuit Diagram
      - 4-2-2. Power Switch Circuit Diagram
      - 4-2-3. Front Switch/USB Circuit Diagram
    - 4-3. ATAPI Conversion Circuit Diagram
    - 4-4. Main Circuit Diagram
      - 4-4-1. AV Output Circuit Diagram
      - 4-4-2. Timer Circuit Diagram
  5. PC BOARDS
    - 5-1. Front FIP PC Board
    - 5-2. Power Switch PC Board
    - 5-3. Front Switch/USB PC Board
    - 5-4. ATAPI PC Board
- 

## SECTION 4 PARTS LIST

### SAFETY PRECAUTION

### NOTICE

### ABBREVIATIONS

### 1. EXPLODED VIEWS

- 1-1. Packing Assembly
- 1-2. Chassis Assembly

### 2. PARTS LIST

# SECTION 1 GENERAL DESCRIPTIONS

## 1. OPERATING INSTRUCTIONS

Please refer to the owner's manual about the contents.

# 2. LOCATION OF MAIN PARTS

## 2-1. Location of Main Parts

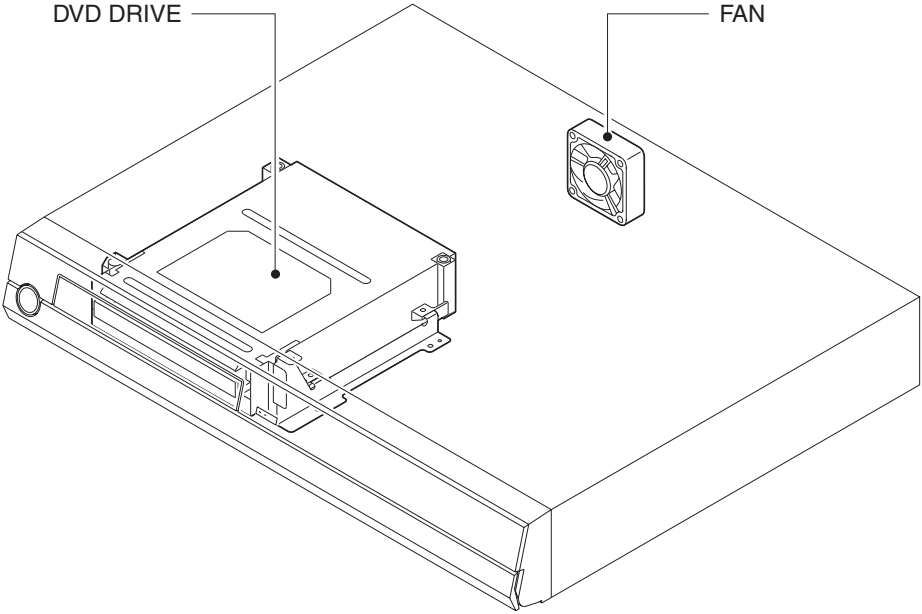

Fig. 1-2-1

## 2-2. Location of PC Boards

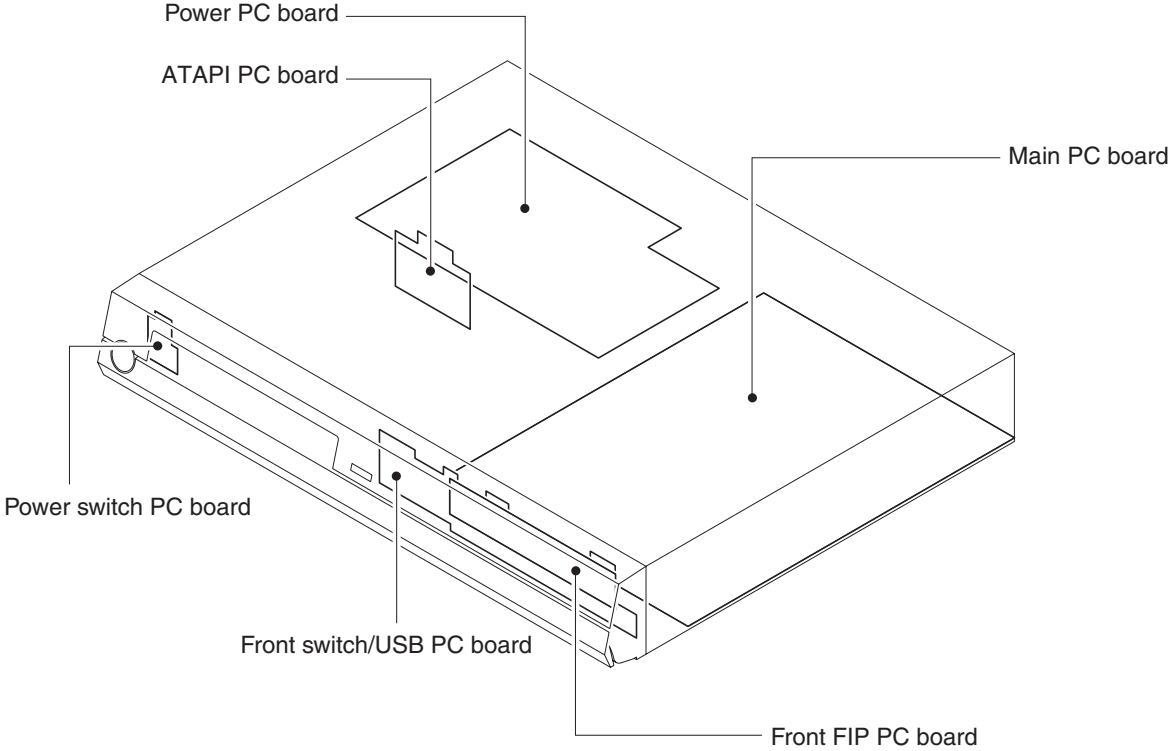

Fig. 1-2-2

# SECTION 2

## PART REPLACEMENT PROCEDURES

### CAUTIONS BEFORE STARTING PART REPLACEMENT

Electronic parts are susceptible to static electricity and may easily be damaged, so do not forget to ground as required. Many screws are used inside the unit. To prevent the screws from missing or dropping, etc. always use a magnetized screwdriver in servicing. Several kinds of screws are used and some of them need special cautions. That is, take care of the tapping screws securing molded parts and fine pitch screws used to secure metal parts. If they are used improperly, the screw holes will be easily damaged and the parts can not be fixed.

### 1. REPLACEMENT OF MECHANICAL PARTS

#### Note:

- Circled numbers in the figure show the main disassembly procedure. Refer to them when disassembling.

#### 1-1. Front Panel, Front PC Boards

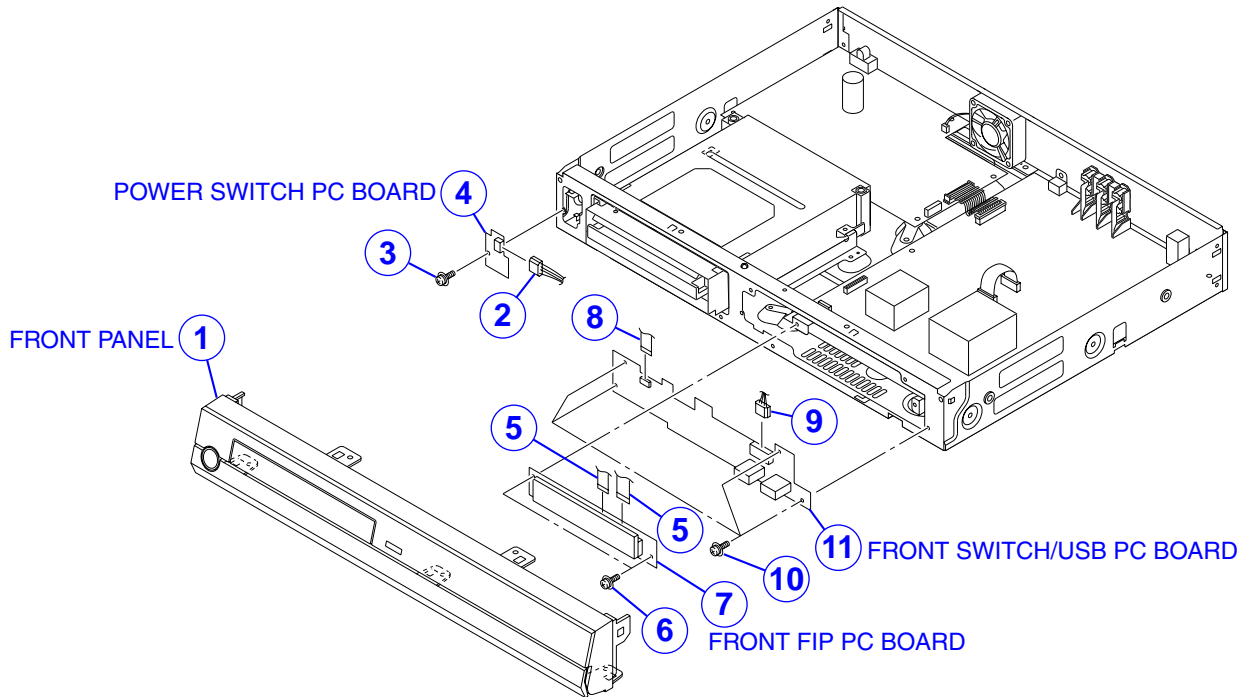

Fig. 2-1-1

## 1-2. Main/Power PC Boards

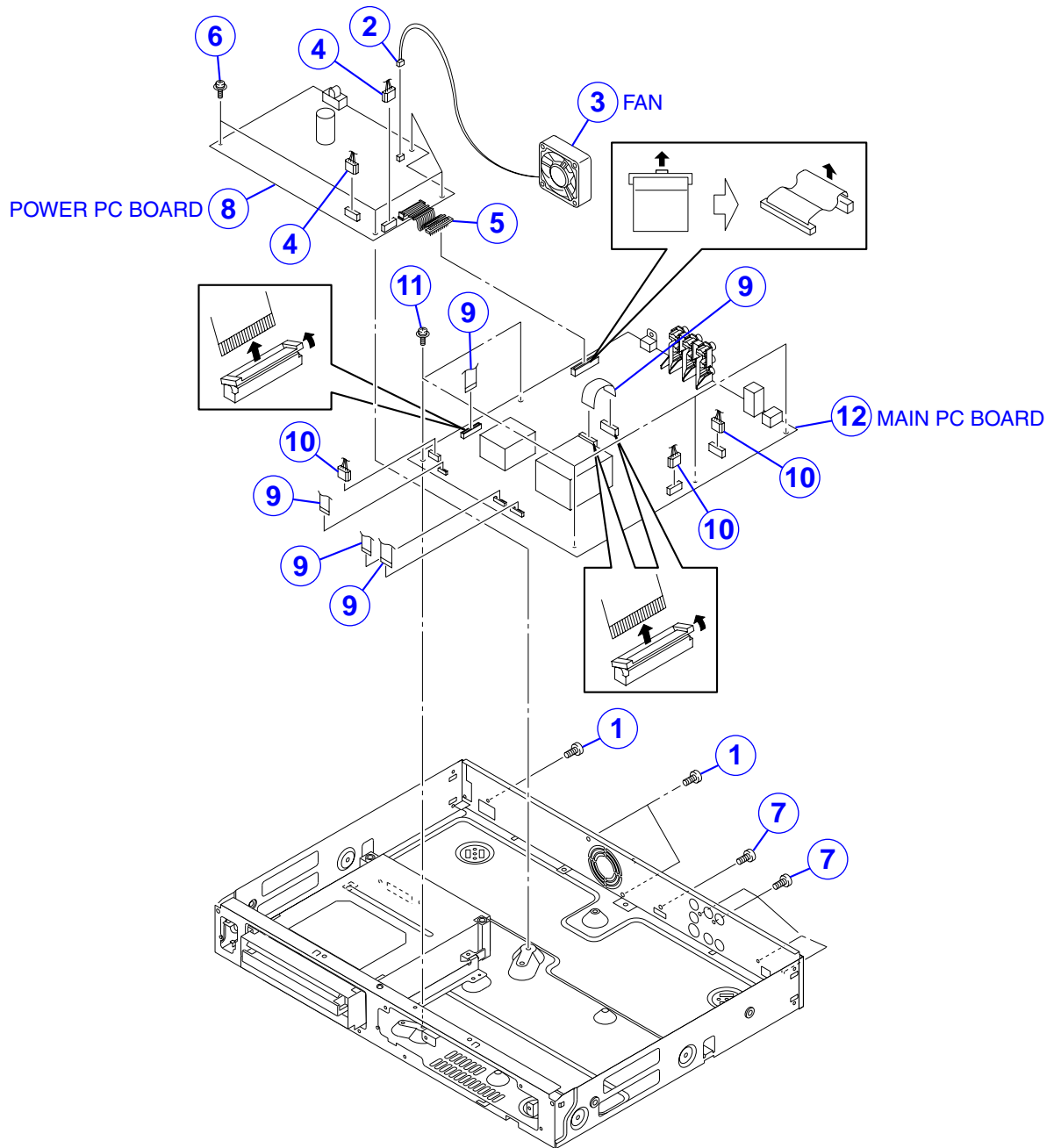

Fig. 2-1-2

### 1-3. DVD Drive

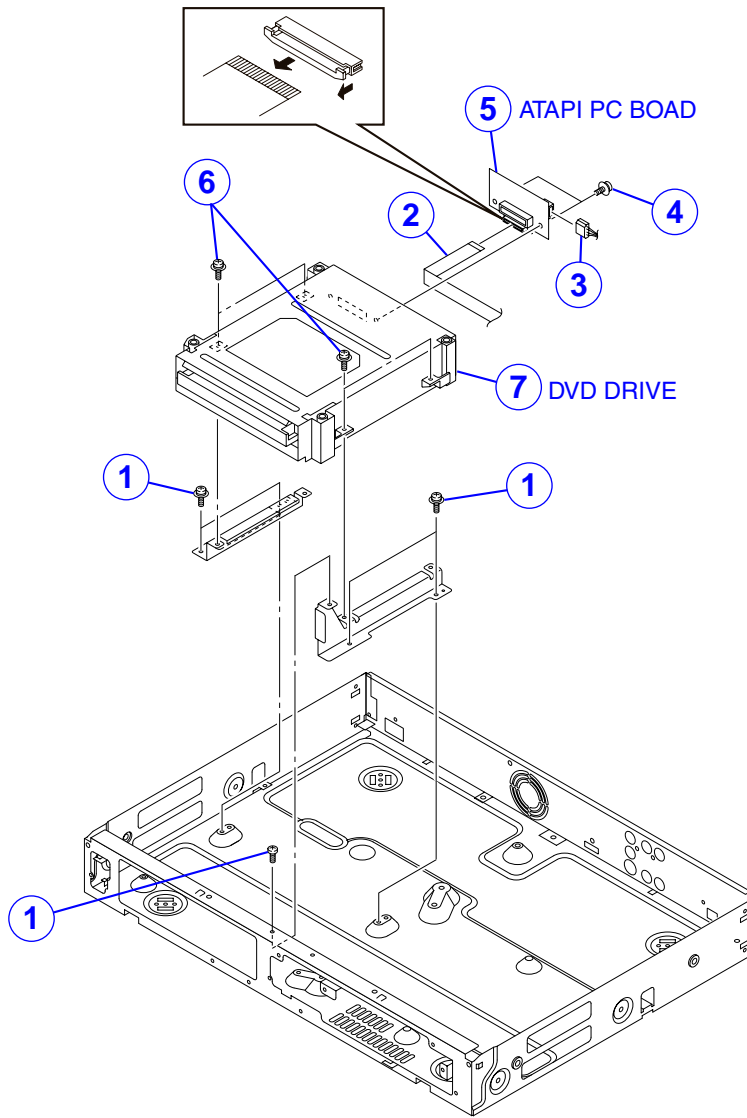

Fig. 2-1-3

## 2. WIRING CONNECTION DIAGRAM

After the servicing is complete, return the wiring to its original state by using the diagram below as a reference.

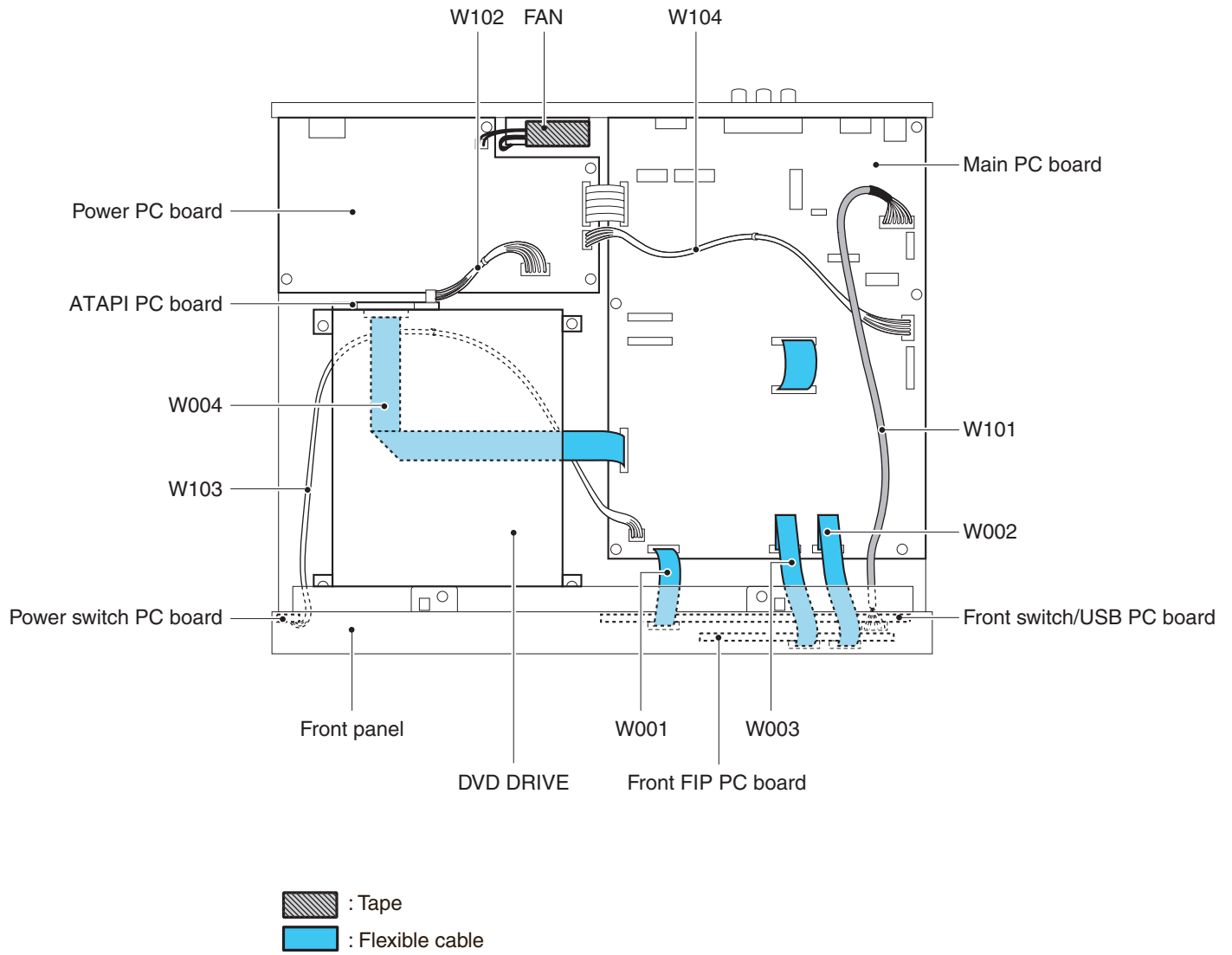

Fig. 2-2-1

# SECTION 3 SERVICING DIAGRAMS

## 1. CIRCUIT SYMBOLS AND SUPPLEMENTARY EXPLANATION

### 1-1. Precautions for Part Replacement

- In the schematic diagram, parts marked  $\triangle$  (ex.  $\triangle$  F801) are critical part to meet the safety regulations, so always use the parts bearing specified part codes (SN) when replacing them.
- Using the parts other than those specified shall violate the regulations, and may cause troubles such as operation failures, fire etc.

### 1-2. Solid Resistor Indication

<b>Unit</b>	None ..... $\Omega$ K ..... $k\Omega$ M ..... $M\Omega$
<b>Tolerance</b>	None ..... $\pm 5\%$ B ..... $\pm 0.1\%$ C ..... $\pm 0.25\%$ D ..... $\pm 0.5\%$ F ..... $\pm 1\%$ G ..... $\pm 2\%$ K ..... $\pm 10\%$ M ..... $\pm 20\%$
<b>Rated Wattage</b>	(1) Chip Parts None ..... 1/16W (2) Other Parts None ..... 1/6W Other than above, described in the Circuit Diagram.
<b>Type</b>	None ..... Carbon film S ..... Solid R ..... Oxide metal film M ..... Metal film W ..... Cement FR ..... Fusible

Eg. 1

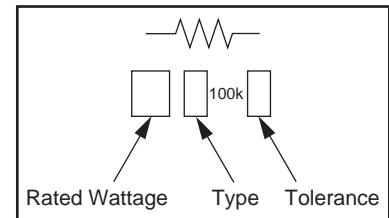

Fig. 3-1-1

### 1-3. Capacitance Indication

<b>Symbol</b>	$\begin{matrix} \text{---} \\ \text{---} \\ \text{---} \end{matrix} \begin{matrix} + \\ \text{NP} \\ \text{---} \end{matrix}$ ..... Electrolytic, Special electrolytic $\begin{matrix} \text{---} \\ \text{---} \\ \text{---} \end{matrix} \begin{matrix} \text{---} \\ \text{---} \\ \text{---} \end{matrix}$ ..... Non polarity electrolytic $\begin{matrix} \text{---} \\ \text{---} \\ \text{---} \end{matrix} \begin{matrix} \text{---} \\ \text{---} \\ \text{---} \end{matrix}$ ..... Ceramic, plastic $\begin{matrix} \text{---} \\ \text{---} \\ \text{---} \end{matrix} \begin{matrix} \text{---} \\ \text{---} \\ \text{---} \end{matrix}$ ..... Film $\begin{matrix} \text{---} \\ \text{---} \\ \text{---} \end{matrix} \begin{matrix} \text{---} \\ \text{---} \\ \text{---} \end{matrix}$ ..... Trimmer
<b>Unit</b>	None ..... F $\mu$ ..... $\mu\text{F}$ p ..... pF
<b>Rated voltage</b>	None ..... 50V For other than 50V and electrolytic capacitors, described in the Circuit Diagram.
<b>Tolerance</b>	(1) Ceramic, plastic, and film capacitors of which capacitance are more than 10 pF. None ..... $\pm 5\%$ or more B ..... $\pm 0.1\%$ C ..... $\pm 0.25\%$ D ..... $\pm 0.5\%$ F ..... $\pm 1\%$ G ..... $\pm 2\%$ (2) Ceramic, plastic, and film capacitors of which capacitance are 10 pF or less. None ..... more than $\pm 5$ pF B ..... $\pm 0.1$ pF C ..... $\pm 0.25$ pF (3) Electrolytic, Trimmer Tolerance is not described.
<b>Temperature characteristic (Ceramic capacitor)</b>	None ..... SL For others, temperature characteristics are described. (For capacitors of 0.01 $\mu\text{F}$ and no indications are described as F.)
<b>Static electricity capacity (Ceramic capacitor)</b>	Sometimes described with abbreviated letters as shown in Eg. 3.

Eg. 2

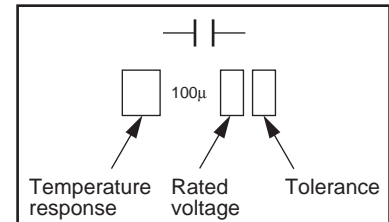

Fig. 3-1-2

Eg. 3

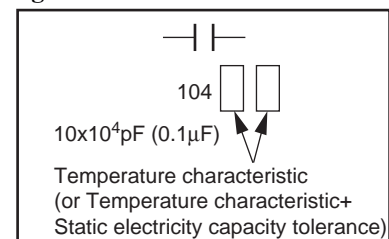

Fig. 3-1-3

### 1-4. Inductor Indication

<b>Unit</b>	None ..... H $\mu$ ..... $\mu$ H m ..... mH
<b>Tolerance</b>	None ..... $\pm 5\%$ B ..... $\pm 0.1\%$ C ..... $\pm 0.25\%$ D ..... $\pm 0.5\%$ F ..... $\pm 1\%$ G ..... $\pm 2\%$ K ..... $\pm 10\%$ M ..... $\pm 20\%$

Eg. 4

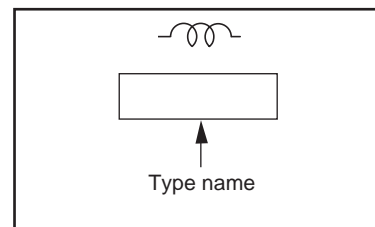

Fig. 3-1-4

### 1-5. Waveform and Voltage Measurement

- The waveforms for CD/DVD and RF shown in the circuit diagrams are obtained when a test disc is played back.
- All voltage values except the waveforms are expressed in DC and measured by a digital voltmeter.

### 1-6. Others

- The parts indicated with "NC" or "KETU" etc. are not used in the circuits of this model.

Eg. 5

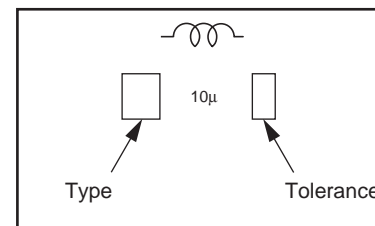

Fig. 3-1-5

## 2. PRINTED WIRING BOARD AND SCHEMATIC DIAGRAM

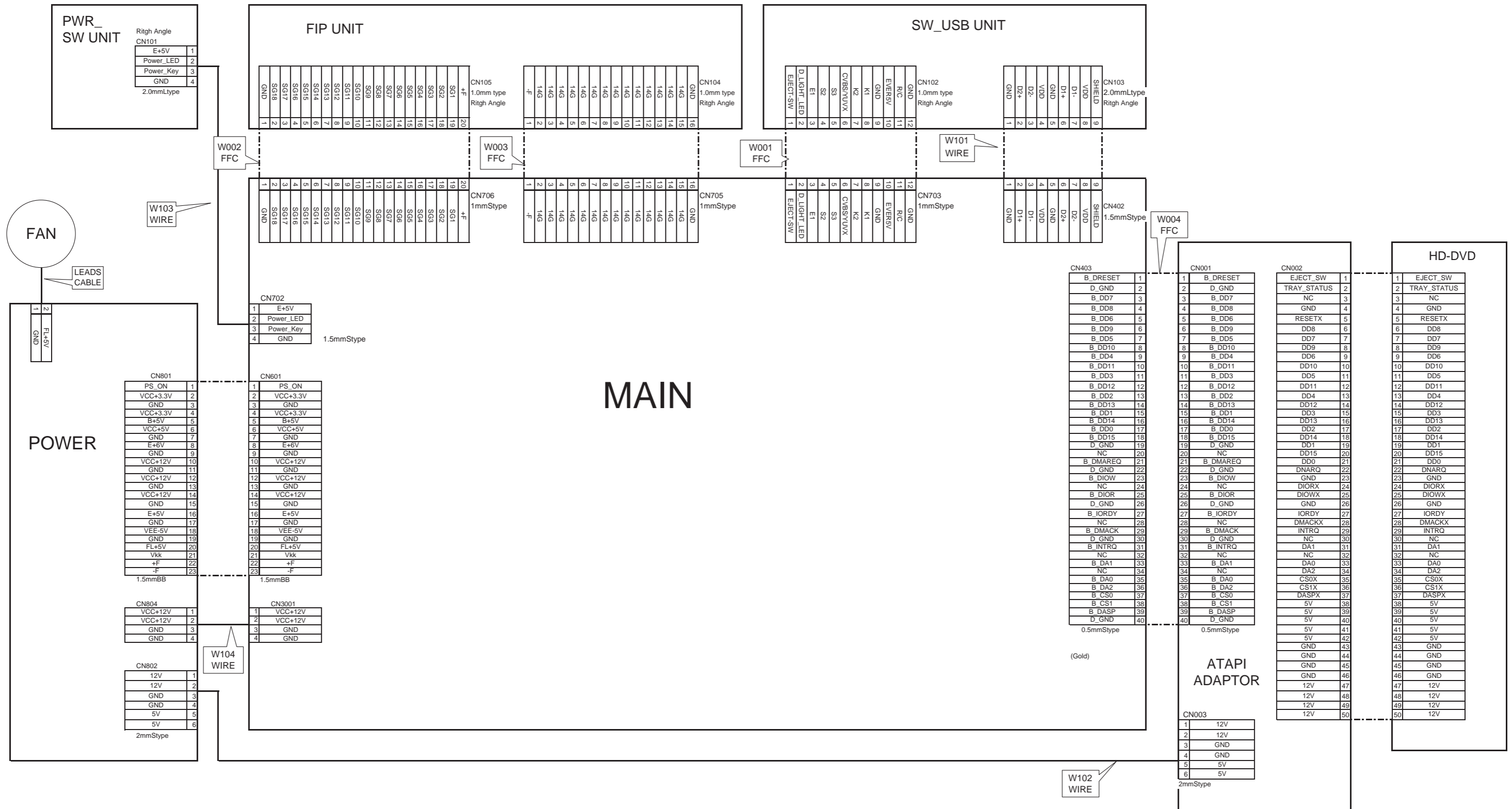

Fig. 3-2-1

### 3. BLOCK DIAGRAMS

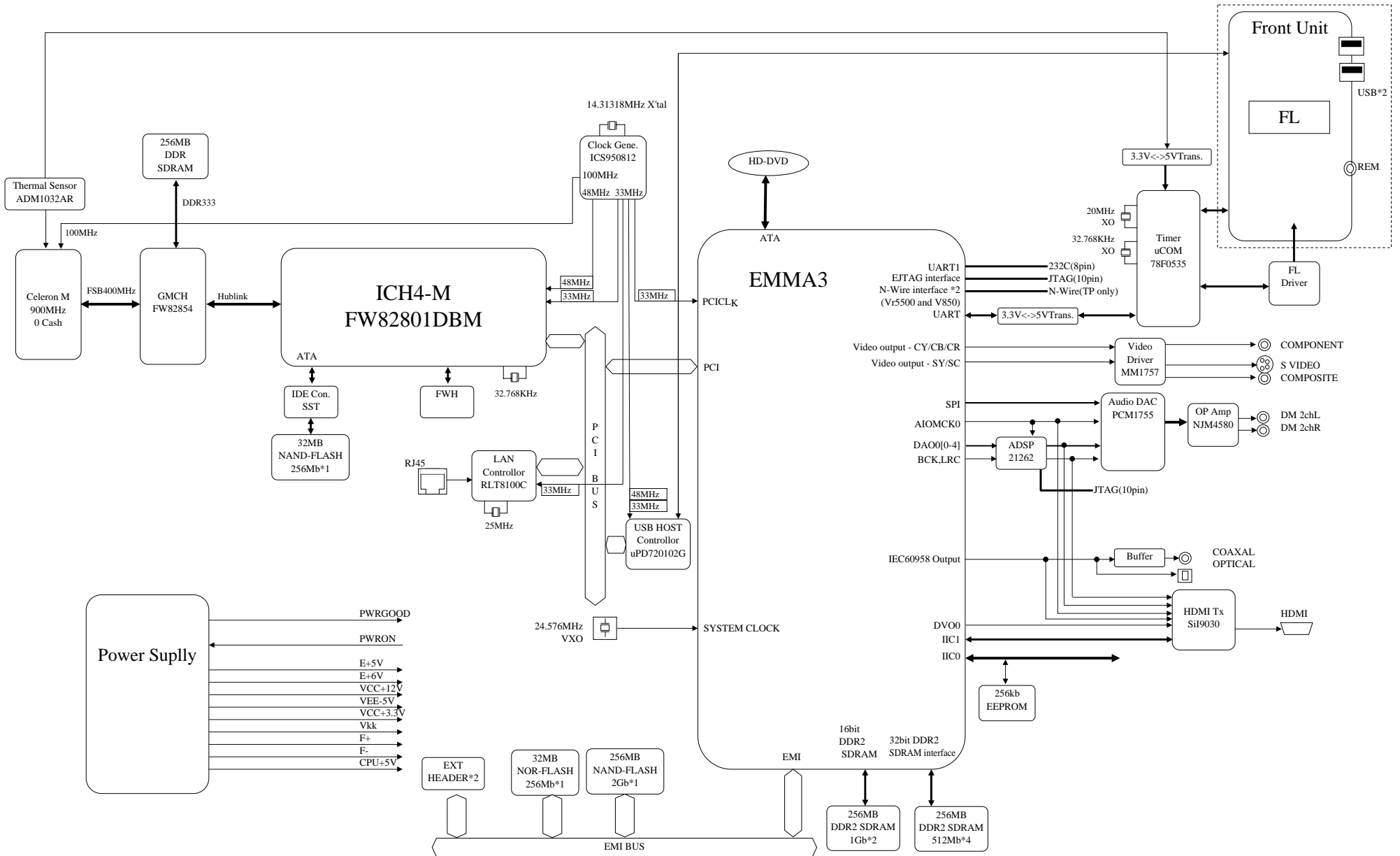
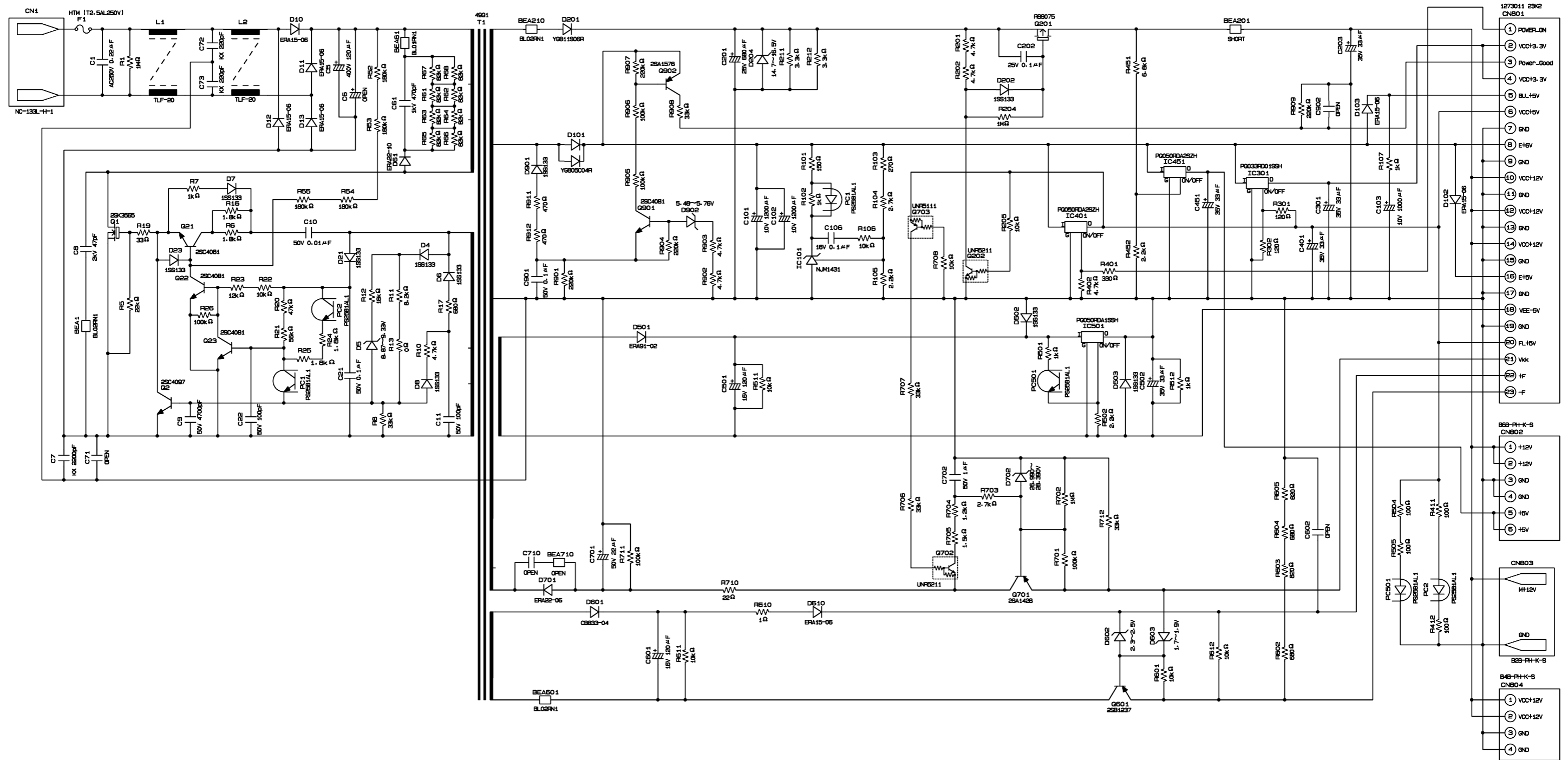

Fig. 3-3-1

# 4. CIRCUIT DIAGRAMS

## 4-1. Power Supply Circuit Diagram



# 4-2. Front Circuit Diagram

## 4-2-1. Front FIP Circuit Diagram

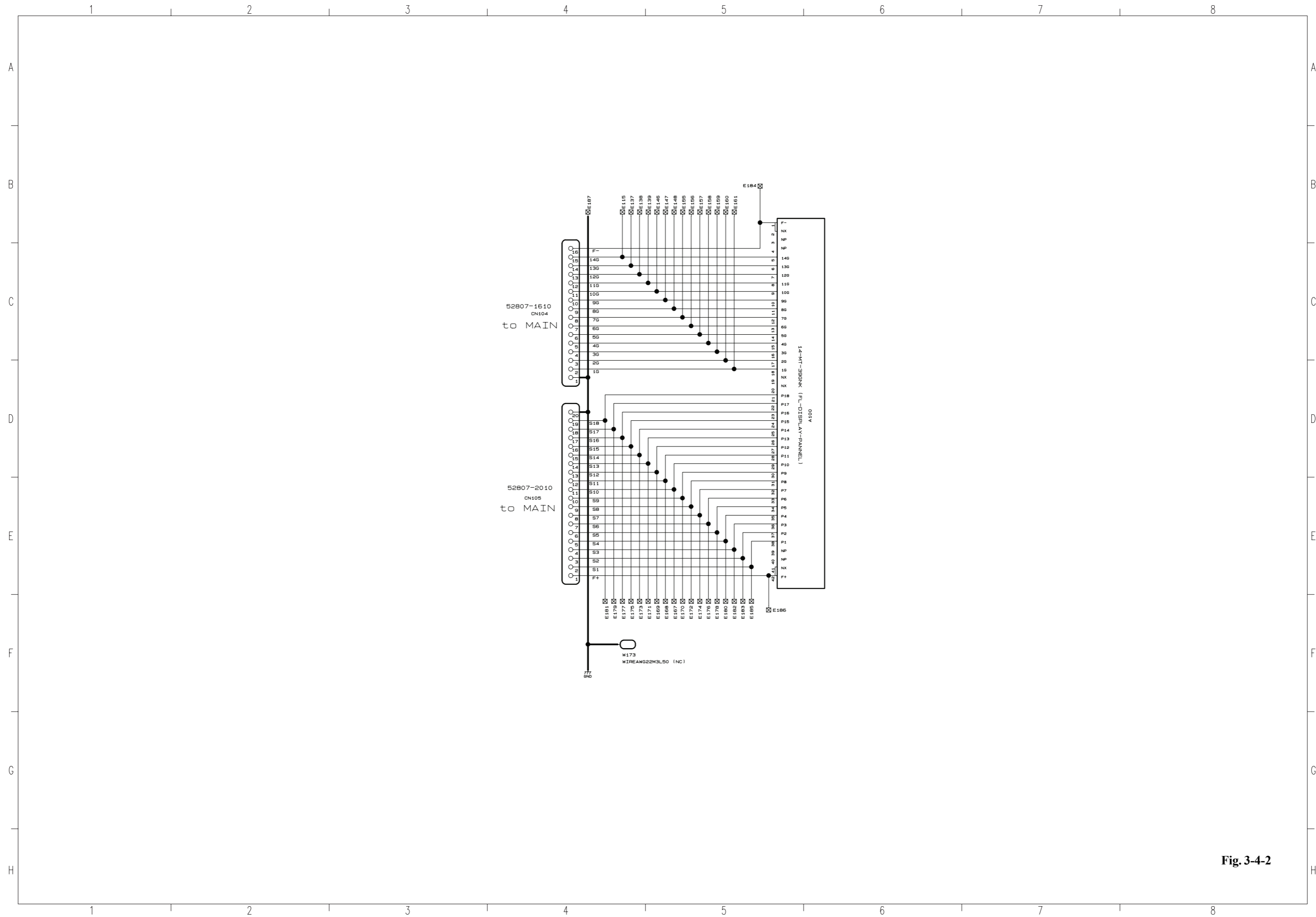

Fig. 3-4-2

### 4-2-2. Power Switch Circuit Diagram

D121	Use
D122	Not use

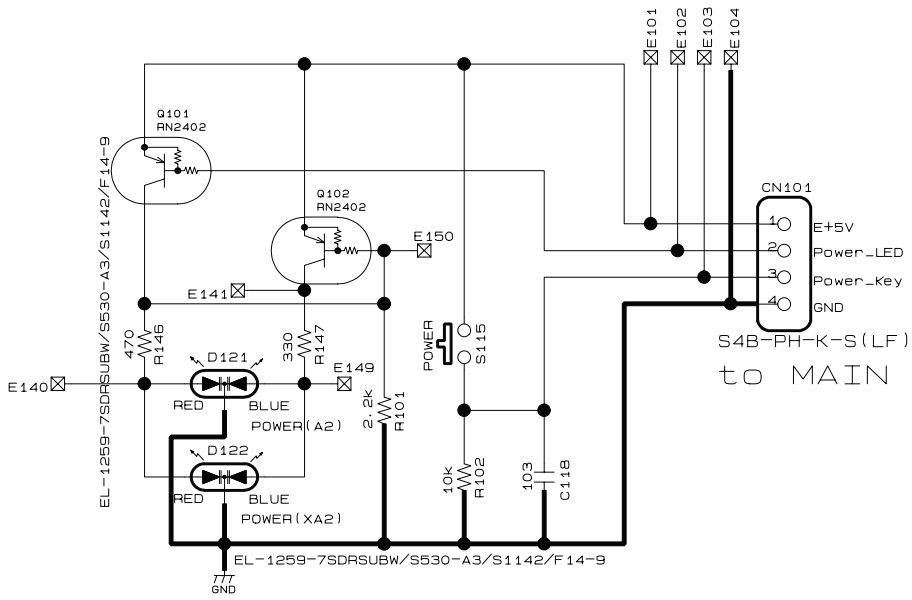

Fig. 3-4-3

4-2-3. Front Switch/USB Circuit Diagram

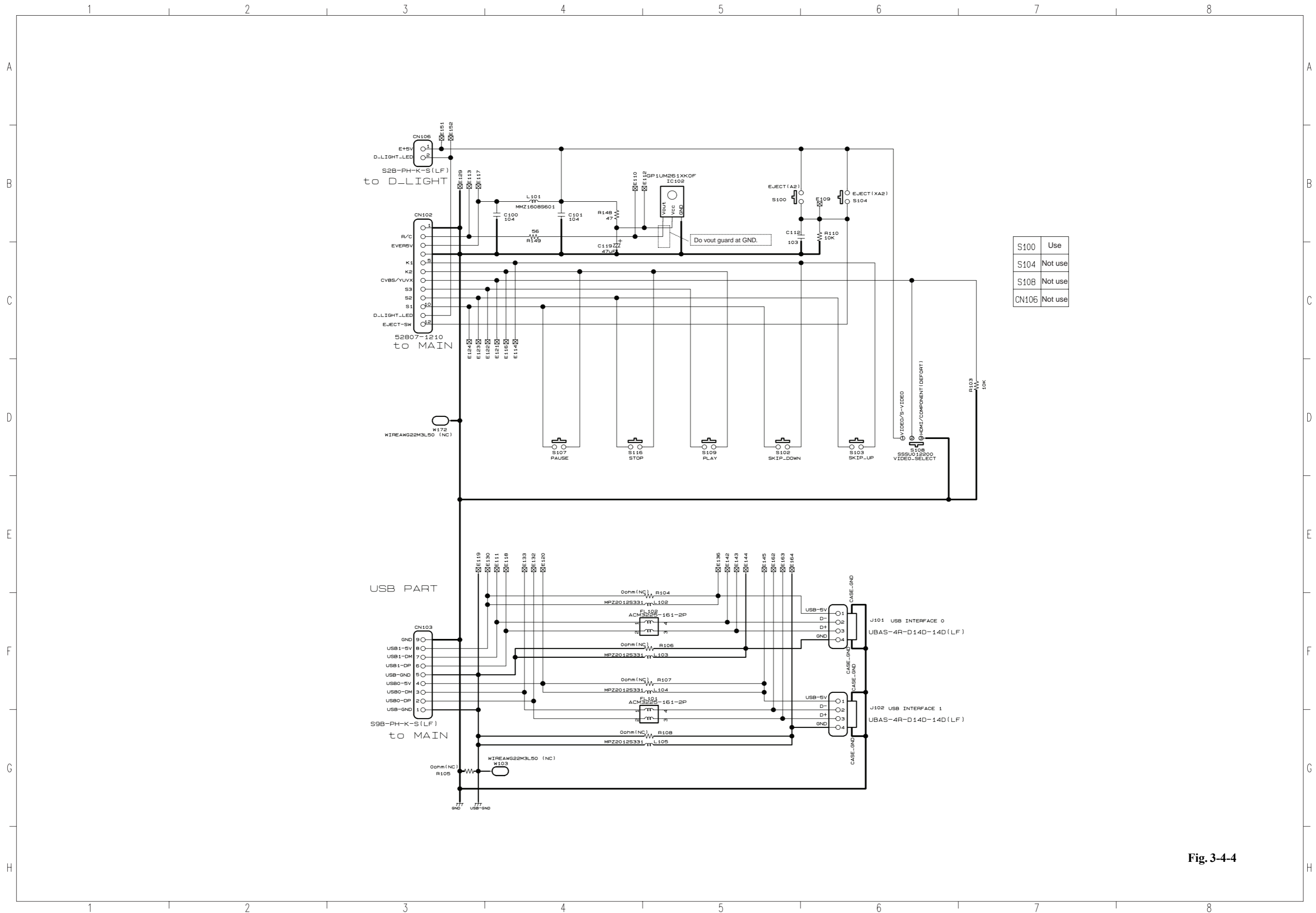

Fig. 3-4-4

### 4-3. ATAPI Conversion Circuit Diagram

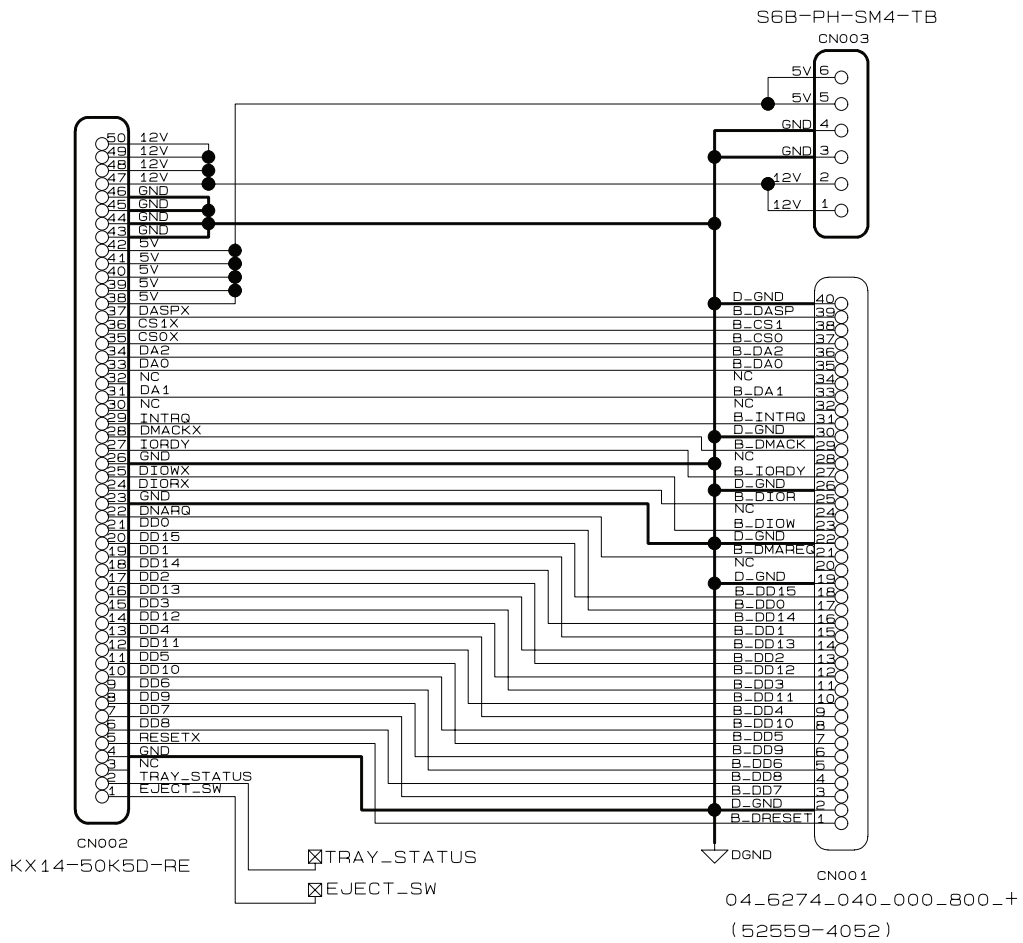

Fig. 3-4-5

# 4-4. Main Circuit Diagram

## 4-4-1. AV Output Circuit Diagram

Note : The main circuit diagrams describe only part of information.

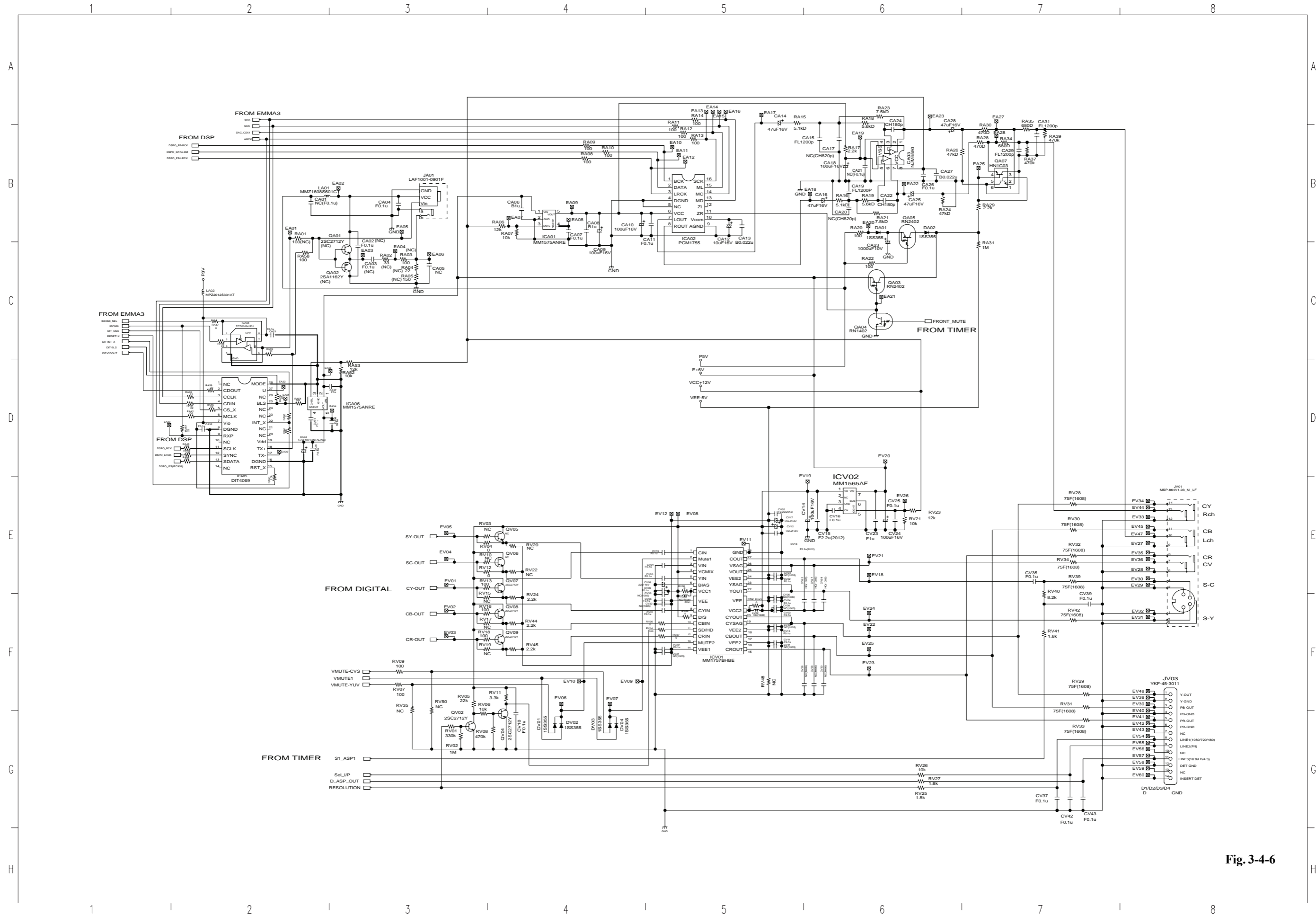

Fig. 3-4-6

# 4-4-2. Timer Circuit Diagram

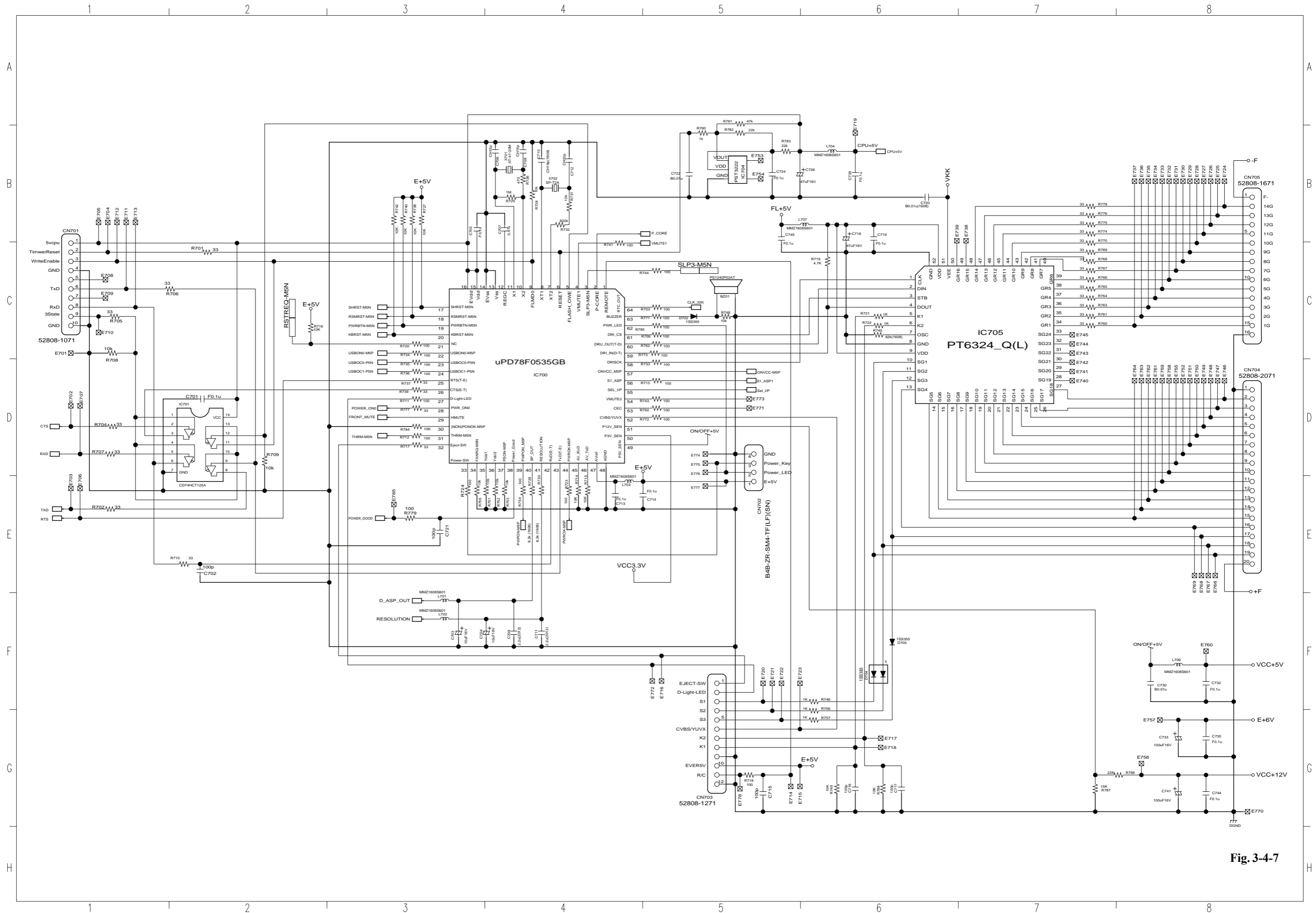

Fig. 3-4-7



### 5-3. Front Switch/USB PC Board

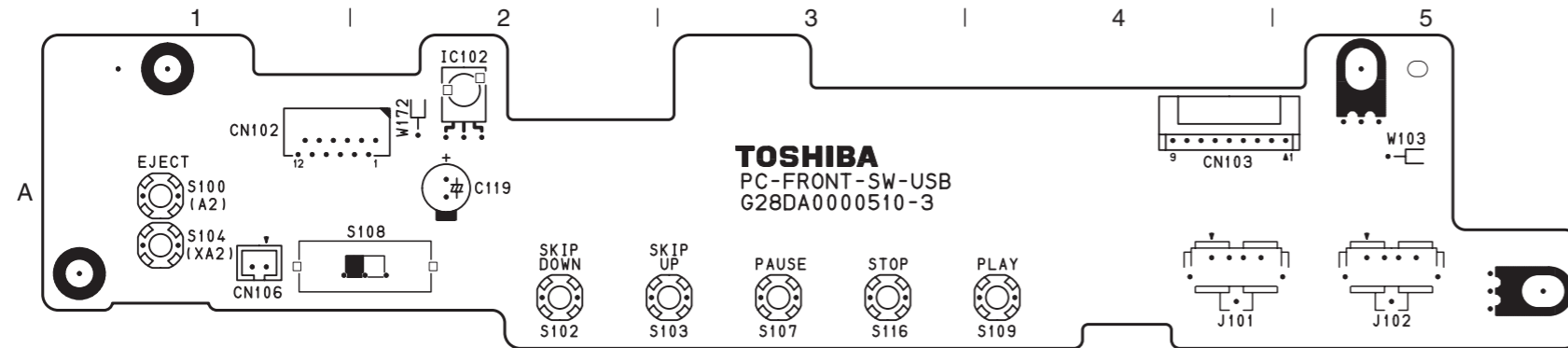

Fig. 3-5-5 Front Switch/USB PC Board (Top side)

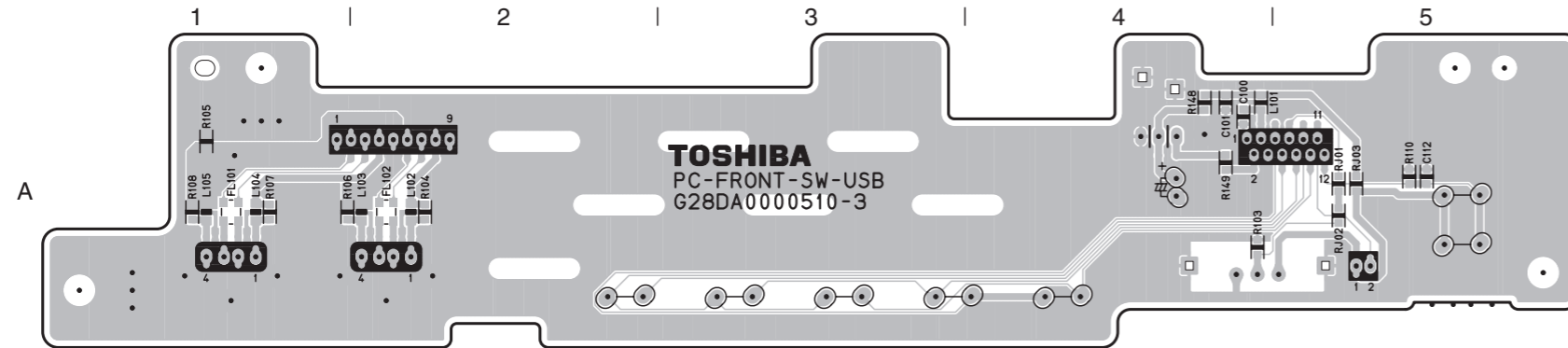

Fig. 3-5-6 Front Switch/USB PC Board (Bottom side)

### 5-4. ATAPI PC Board

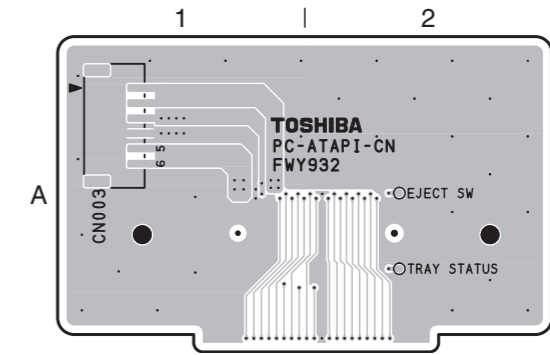

Fig. 3-5-7 ATAPI PC Board (Top side)

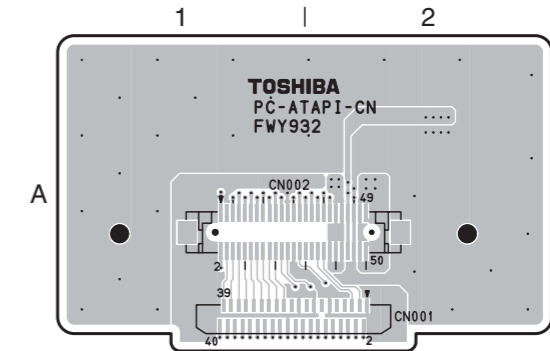

Fig. 3-5-8 ATAPI PC Board (Bottom side)

# SECTION 4 PARTS LIST

## SAFETY PRECAUTION

The parts identified by ! ( $\triangle$ ) mark are critical for safety. Replace only with part number specified.

The mounting position of replacement is to be identical with originals.

The substitute replacement parts which do not have the same safety characteristics as specified in the parts list may create shock, fire or other hazards.

## NOTICE

The part number must be used when ordering parts in order to assist in processing, be sure to include the model number and description.

## ABBREVIATIONS

- **Integrated Circuit (IC)**
- **Capacitor (Cap)**
  - **Capacitance Tolerance (for Nominal Capacitance more than 10pF)**

Table 4-2-1

Symbol	B	C	D	F	G	J	K	M	N
Tolerance %	±0.1	±0.25	±0.5	±1	±2	±5	±10	±20	±30

Symbol	P	Q	T	U	V	W	X	Y	Z
Tolerance %	+100 0	+30 -10	+50 -10	+75 -10	+20 -10	+100 -10	+40 -20	+150 -10	+80 -20

Ex. 10 $\mu$ F J = 10 $\mu$ F ± 5%

- **Capacitance Tolerance (for Nominal Capacitance 10pF or less)**

Table 4-2-2

Symbol	B	C	D	F	G
Tolerance pF	±0.1	±0.25	±0.5	±1	±2

Ex. 10pF G = 10pF ± 2pF

- **Resistor (Res)**
  - **Resistance tolerance**

Table 4-3-1

Symbol	B	C	D	F	G	J	K	M
Tolerance %	±0.1	±0.25	±0.5	±1	±2	±5	±10	±20

Ex. 470 $\Omega$ J = 470 $\Omega$  ± 5%

# 1. EXPLODED VIEWS

## 1-1. Packing Assembly

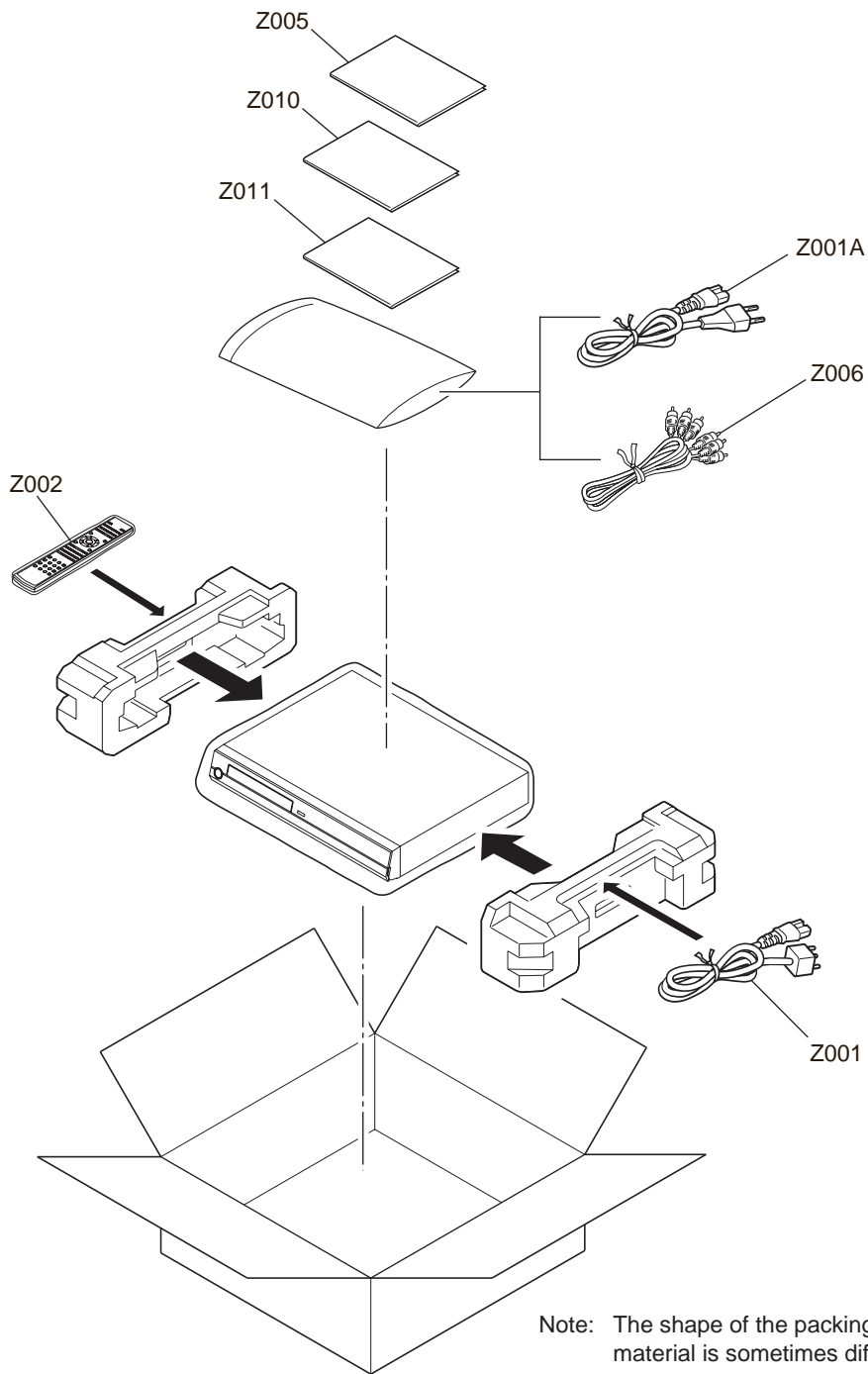

Note: The shape of the packing material is sometimes different.

Fig. 4-1-1

## 1-2. Chassis Assembly

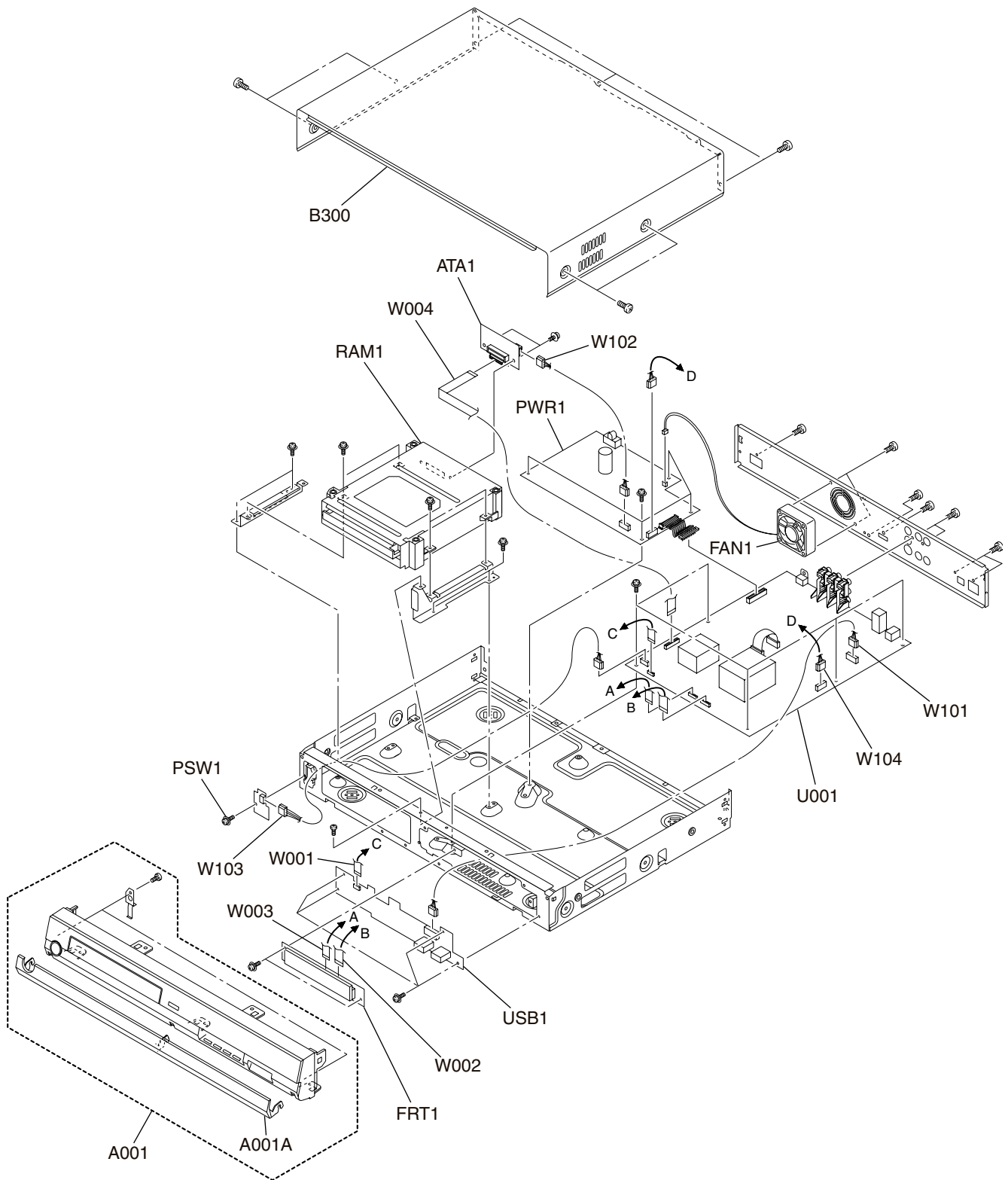

Fig. 4-1-2

## 2.PARTS LIST

Location No.	Part No.	Description
- ELECTRICAL PARTS -		
U001	P000477830	PC BOARD ASSY, MAIN
▲ PWR1	P000477740	POWER UNIT, MPN5115
FRT1	P000477360	PC BOARD ASSY, FRONT
PSW1	P000477610	PC BOARD ASSY, POWER-SW
USB1	P000477630	PC BOARD ASSY, FRONT SW/USB
ATA1	P000477350	ATAPI-FFC ADAPTER
- MECHANICAL PARTS -		
A001	P000477750	PANEL ASSY, FRONT
A001A	P000477760	DOOR, FRONT
B300	P000477380	COVER, TOP
FAN1	P000477470	FAN DC, DSB0512LD-6T10
▲ RAM1	P000477500	HD-DVD-DRIVE, SD-E802A
W001	P000477420	FFC-12P-L102 MAIN-FRONT
W002	P000477430	FFC-20P-L102 MAIN-FRONT
W003	P000477440	FFC-16P-L102 MAIN-FRONT
W004	P000477450	FFC-40P-L242 MAIN-DRIVE
W101	P000477530	WIRE CABLE ZHR-9P-L300 MAIN-USB
W102	P000477540	WIRE CABLE PHR-6P-L100 POWER-ATAPI
W103	P000477550	WIRE CABLE ZHR-4P-L380 MAIN-PWRSW
W104	P000477560	WIRE CABLE PHR-4P-L260 MAIN-POWER
▲ Z001	P000354930	CORD POWER, UK-SET
▲ Z001A	P000477770	CORD POWER, TE-SET
Z002	P000477490	REMOTE CONTROL, SE-R0252
Z006	P000477520	AV CABLE, 3P-L1500 GR
▲ Z005	P000477780	OWNERS MANUAL, ENGLISH
▲ Z010	P000477790	OWNERS MANUAL, GERMANY
▲ Z011	P000477800	OWNERS MANUAL, FRENCH

# SPECIFICATIONS

Power requirement	41.0W
Power supply	220-240V AC 50/60Hz
Mass	4.1kg
External dimension	Width 430 x Height 65.5 x Depth 345mm
Signal system	Standard PAL/NTSC Color TV system
Laser	Semiconductor laser, Wavelength: 405nm/650nm/780nm
VIDEO output	1.0Vp-p (75Ω), Sync signal negative, Pin jack x 1 system
S-VIDEO output	(Y) 1.0Vp-p (75Ω), Sync signal negative, (C) 0.286Vp-p (75Ω), 1 at rear Mini DIN4 Pin x 1 system
COMPONENT output (Y, P <sub>B</sub> , P <sub>R</sub> )	Y output (green), 1.0Vp-p (75Ω), Sync signal negative, Pin jack x 1 system P <sub>B</sub> , P <sub>R</sub> output (blue, red), 0.7Vp-p (75Ω), Pin jack x 1 system each
ANALOG AUDIO output	2.0V (rms), 2.2kΩ or below, pin jack (L, R) x 1 system
DIGITAL AUDIO OUTPUT (BITSTREAM/PCM jack)	Optical connector x 1 system
LAN port	100BASE-TX/10BASE-T x 1
EXTENSION port	EXTENSION port x 2 systems
HDMI output	19 pin
Remote control	Wireless remote control (SE-R0252)
Operating conditions	Temperature: 41°F ~ 95°F (5°C ~ 35°C), Position: Horizontal
Clock accuracy	Quartz (monthly deviation: approximately ±30 seconds)

- This model complies with the above specifications.
- Designs and specifications are subject to change without notice.
- This model may not be compatible with features and/or specifications that may be added in the future.
- The Illustrations and screens described in this manual may be exaggerated or simplified for easy recognition and may be slightly different from the actual unit.

**TOSHIBA CORPORATION**

1-1, SHIBAURA 1-CHOME, MINATO-KU, TOKYO 105-8001, JAPAN