

TOSHIBA

FILE NO. 810-200695GR

SERVICE MANUAL



HD DVD PLAYER

HD-XE1KE

HD-XE1KY



The above models are classified as green products (*1), as indicated by the underlined serial numbers. This Service Manual describes replacement parts for the green products. When repairing these green product(s), use the part(s) described in this manual and lead-free solder (*2).

For (*1) and (*2), see the next page.

Dec., 2006 GREEN

(*1)

GREEN PRODUCT PROCUREMENT

The EC is actively promoting the WEEE & RoHS Directives that define standards for recycling and reuse of Waste Electrical and Electronic Equipment and for the Restriction of the use of certain Hazardous Substances. From July 1, 2006, the RoHS Directive will prohibit any marketing of new products containing the restricted substances.

Increasing attention is given to issues related to the global environmental. Toshiba Corporation recognizes environmental protection as a key management tasks, and is doing its utmost to enhance and improve the quality and scope of its environmental activities. In line with this, Toshiba proactively promotes Green Procurement, and seeks to purchase and use products, parts and materials that have low environmental impacts.

Green procurement of parts is not only confined to manufacture. The same green parts used in manufacture must also be used as replacement parts.

(*2)

LEAD-FREE SOLDER

This product is manufactured using lead-free solder as a part of a movement within the consumer products industry at large to be environmentally responsible. Lead-free solder must be used in the servicing and repair of this product.

WARNING

This product is manufactured using lead free solder.

DO NOT USE LEAD BASED SOLDER TO REPAIR THIS PRODUCT !

The melting temperature of lead-free solder is higher than that of leaded solder by 86°F to 104°F (30°C to 40°C). Use of a soldering iron designed for lead-based solders to repair product made with lead-free solder may result in damage to the component and or PCB being soldered. Great care should be made to ensure high-quality soldering when servicing this product especially when soldering large components, through-hole pins, and on PCBs as the level of heat required to melt lead-free solder is high.

SAFETY INSTRUCTIONS

WARNING: BEFORE SERVICING THIS CHASSIS, READ THE " SAFETY PRECAUTION " AND " PRODUCT SAFETY NOTICE " INSTRUCTIONS BELOW.

SAFETY PRECAUTION

WARNING: SERVICE SHOULD NOT BE ATTEMPTED BY ANYONE UNFAMILIAR WITH THE NECESSARY PRECAUTIONS ON THIS RECEIVER. THE FOLLOWING ARE THE NECESSARY PRECAUTIONS TO BE OBSERVED BEFORE SERVICING THIS CHASSIS.

- An isolation transformer should be connected in the power line between the receiver and the AC line before any service is performed on the receiver.
- When replacing a chassis in the cabinet, always be certain that all the protective devices are put back in place, such as; nonmetallic control knobs, insulating covers, shields, isolation resistor-capacitor network etc.
- Always advise users to keep children away. There is danger of injury to children from tools, disassembled products, etc.
- Always disconnect the power plug before starting work whenever power is not required. Failure to disconnect the power plug before starting work can result in electrical shock.
- Depending on the model, use an insulation transformer or wear gloves when servicing with the power on, and disconnect the power plug to avoid electrical shock when replacing parts. In some cases, alternating current is also impressed in the chassis, so electrical shock is possible if the chassis is contacted with the power on.
- Always use the replacement parts specified for the particular model when making repairs. The parts used in products have the necessary safety characteristics such as inflammability, voltage resistance, etc. ; therefore, use only replacement parts that have these same characteristics. Use only the  specified parts when the mark is include in a circuit diagram or parts list.
- Parts mounting and routing of the wiring should be the same as that used originally. For safety purposes, insulating materials such as tubing or tape is sometimes used and printed circuit boards are sometimes mounted floating. Also make sure that wiring is routed and clamped to avoid parts that generate heat and which use high voltage. Always follow the original scheme.
- After a repair has been completed, reassemble all disassembled pars, and route and reconnect the wiring, in accordance with the original scheme. Do not allow internal wiring to be pinched by cabinets, panels, etc. Any error in reassembly or wiring can result in electrical leakage, flame, etc.,and may be hazardous.
- Never remodel the product in any way. Remodeling can result in improper operation, malfunction, or electrical leakage and flame, which may be hazardous.

Touch current check

(After completing the work, measure touch current to prevent an electric shock.)

- Plug the AC cord directly into the AC outlet. Do not use an isolation transformer for this check..
- Connect a measuring network for touch currents between each exposed metallic part on the set and a good earth ground such as a water pipe, as shown in Figure D.1
- The potential at any point(TOUCH CURRENT) expressed as voltage U_1 and U_2 does not exceed the following value:

The part or contact of a *TERMINAL* is not *HAZARDOUS LIVE* if:

a) the open-circuit voltage does not exceed 35 V (peak) a.c. or 60 V d.c.,

or, if a) is not met,

b) the measurement of the TOUCH-CURRENT shall be carried out in accordance with IEC 60990, with the measuring network described in annex D of this standard.

The TOUCH CURRENT expressed as voltages U_1 and U_2 , does not exceed the following values:

- for a.c.: $U_1 = 35$ V (peak) and $U_2 = 0.35$ V (peak);

- for d.c.: $U_1 = 1,0$ V,

NOTE 5 -The limit values of $U_2 = 0.35$ V (peak) for a.c. and $U_1 = 1.0$ V for d.c. correspond, to the values 0,7mA (peak) a.c. and 2,0 mA 2,0mA d.c.

The limit value $U_1 = 35$ V (peak) for a.c. corresponds to the value 70mA (peak) a.c. for frequencies greater than 100 kHz.

Annex D
(normative)
Measuring network for TOUCH CURRENTS

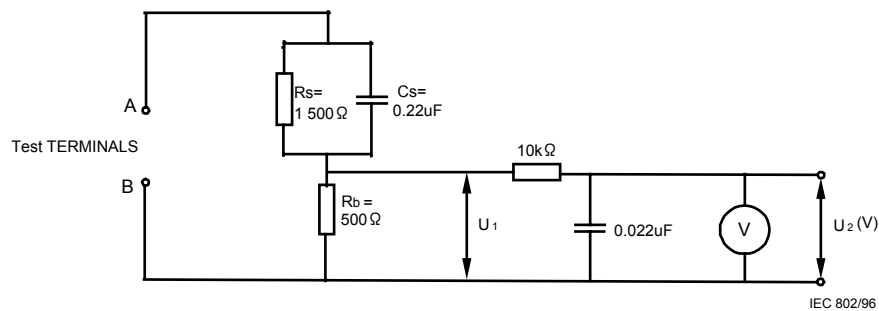

Resistance values in ohms(Ω)

V: Voltmeter or oscilloscope
(r.m.s or peak reading)

Input resistance: ≥ 1 M Ω

Input capacitance: ≤ 200 pF

Frequency range: 15 Hz to 1 MHz and d.c. respectively

NOTE-Appropriate measures should be taken to obtain the correct value in case of non-sinusoidal waveforms.

The measuring instrument is calibrated by comparing the frequency factor of U_2 with the solid line in figure F.2 of IEC 60990 at various frequencies. A calibration curve is constructed showing the deviation of U_2 from the ideal curve as a function of frequency.

TOUCH CURRENT = $U_2 / 500$ (peak value)

Fig.D.1

PRODUCT SAFETY NOTICE

Many electrical and mechanical parts in this chassis have special safety-related characteristics. These characteristics are often passed unnoticed by a visual inspection and the protection afforded by them cannot necessarily be obtained by using replacement components rated for higher voltage, wattage, etc. Replacement parts which have these special safety characteristics are identified in this manual and its supplements; electrical components having such features are identified by the international hazard symbols on the schematic diagram and the parts list. Before replacing any of these components, read the parts list in this manual carefully. The use of substitute replacement parts which do not have the same safety characteristics as specified in the parts list may create shock, fire, or other hazards.



The lightning flash with arrowhead symbol, within an equilateral triangle, is intended to alert the user to the presence of uninsulated “ dangerous voltage ” within the products enclosure that may be of sufficient magnitude to constitute a risk of electric shock to persons.



The exclamation point within an equilateral triangle is intended to alert the user to the presence of important operating and maintenance (servicing) instructions in the literature accompanying the appliance.

LASER BEAM CAUTION LABEL

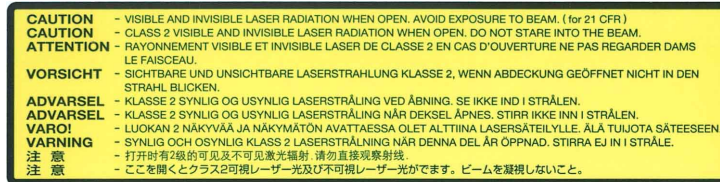

When the power supply is being turned on, you may not remove this laser cautions label. If it removes, radiation of a laser may be received.

PREPARATION OF SERVICING

Pickup Head consists of a laser diode that is very susceptible to external static electricity.

Although it operates properly after replacement, if it was subject to electrostatic discharge during replacement, its life might be shortened. When replacing, use a conductive mat, soldering iron with ground wire, etc. to protect the laser diode from damage by static electricity.

And also, the LSI and IC are same as above.

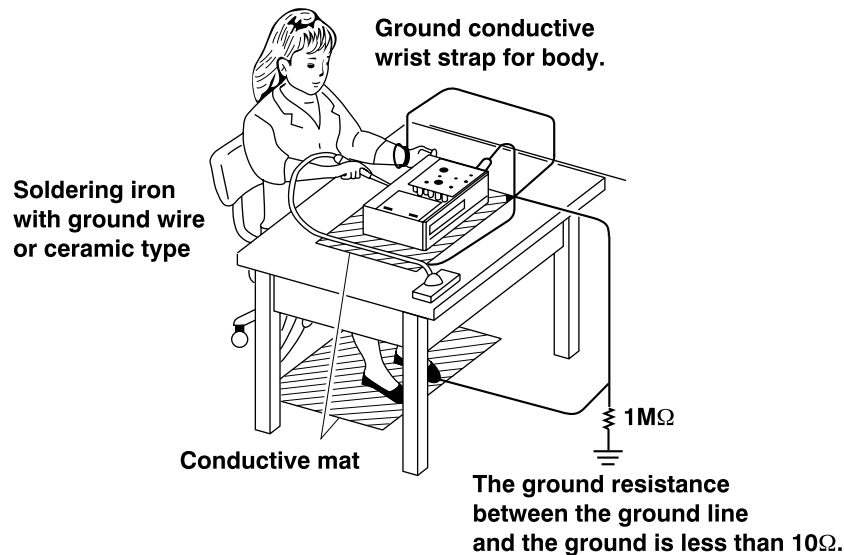

- Dolby features manufactured under license from Dolby Laboratories. Dolby and the double-D symbol are trademarks of Dolby Laboratories.
- DTS features manufactured under license from Digital Theater Systems, Inc. U.S. Pat. No's. 5,451,942; 5,956,674; 5,974,380; 5,978,762; 6,226,616; 6,487,535 and other U.S. and world-wide patents issued and pending. "DTS" and "DTS Digital Surround" are registered trademarks of Digital Theater Systems, Inc.
Copyright 1996, 2003 Digital Theater Systems, Inc. All Rights Reserved.
- HDMI, the HDMI logo and High-Definition Multimedia Interface are trademarks or registered trademarks of HDMI Licensing LLC.
- SHARC is a registered trademark and Melody is a trademark of Analog Devices, Inc.
- All other brand and product names mentioned in this manual are trademarks and/or registered trademarks of their respective holders.

CONTENTS

SECTION 1 GENERAL DESCRIPTIONS

- | | |
|----------------------------------|----------------------------------|
| 1. OPERATING INSTRUCTIONS | 2. LOCATION OF MAIN PARTS |
| | 2-1. Location of Main Parts |
| | 2-2. Location of PC Boards |
-

SECTION 2 PART REPLACEMENT PROCEDURES

- | | |
|---|--|
| 1. REPLACEMENT OF MECHANICAL PARTS | 2. WIRING CONNECTION DIAGRAM |
| 1-1. Front Panel, Front PC Boards | 2-1. Wiring Connection Diagram |
| 1-2. Main/Power PC Boards | 2-2. Supplementary Instructions for Reassembling |
| 1-3. DVD Drive | |
-

SECTION 3 SERVICING DIAGRAMS

- | | |
|---|---------------------------------------|
| 1. CIRCUIT SYMBOLS AND SUPPLEMENTARY EXPLANATION | 4-4. Main Circuit Diagram |
| 1-1. Precautions for Part Replacement | 4-4-1. AV Output Circuit Diagram |
| 1-2. Solid Resistor Indication | 4-4-2. Timer Circuit Diagram |
| 1-3. Capacitance Indication | 4-4-3. Video Scaller Circuit Diagram |
| 1-4. Inductor Indication | 4-4-4. Video Output Circuit Diagram |
| 1-5. Waveform and Voltage Measurement | 4-5. ATAPI Conversion Circuit Diagram |
| 1-6. Others | 5. PC BOARDS |
| 2. PRINTED WIRING BOARD AND SCHEMATIC DIAGRAM | 5-1. Front FIP PC Board |
| 3. BLOCK DIAGRAMS | 5-2. Power Switch PC Board |
| 4. CIRCUIT DIAGRAMS | 5-3. Front Switch/USB PC Board |
| 4-1. Power Supply Circuit Diagram | 5-4. ATAPI PC Board |
| 4-2. Front Circuit Diagram | 5-5. D-Light PC Board |
| 4-2-1. Front FIP Circuit Diagram | 5-6. RS232C PC Board |
| 4-2-2. Power Switch Circuit Diagram | |
| 4-2-3. Front Switch/USB Circuit Diagram | |
| 4-2-4. Front D-Light Circuit Diagram | |
| 4-3. RS232C Circuit Diagram | |
-

SECTION 4 PARTS LIST

SAFETY PRECAUTION NOTICE

ABBREVIATIONS

1. EXPLODED VIEWS

- 1-1. Packing Assembly
- 1-2. Chassis Assembly

2. PARTS LIST

SUPPLEMENT

SUPPLEMENT1. Firmware Version Update

SUPPLEMENT2. Error Code

SUPPLEMENT3. TROUBLESHOOTING

- 3-1. Standby LED (red) does not light.
- 3-2. LED (green) does not light at power on.
- 3-3. CPU FAN does not work.
- 3-4. Indicator does not light. ("WELCOME" does not light at startup.)
- 3-5. System does not run. ("WELCOME" displayed and key operation disabled)
- 3-6. No picture appears.
- 3-6-1. No output from HDMI.

3-7. No audio is played back.

3-8. Buzzer does not sound.

3-9. Extension port does not work.

3-10. Front panel keys/remote control are disabled.

3-11. Other Symptoms

3-12. Power Circuit Troubleshooting

SECTION 1 GENERAL DESCRIPTIONS

1. OPERATING INSTRUCTIONS

Please refer to the owner's manual about the contents.

2. LOCATION OF MAIN PARTS

2-1. Location of Main Parts

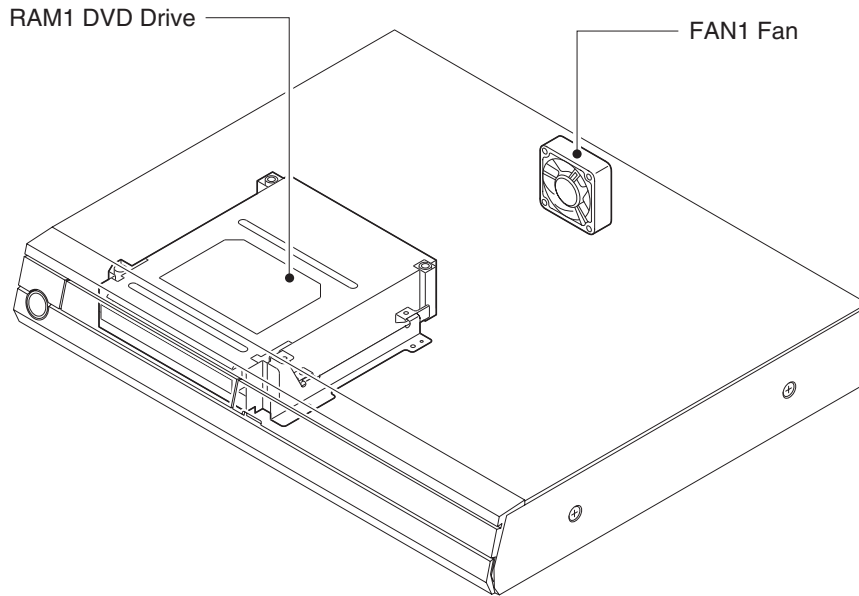

Fig. 1-2-1

2-2. Location of PC Boards

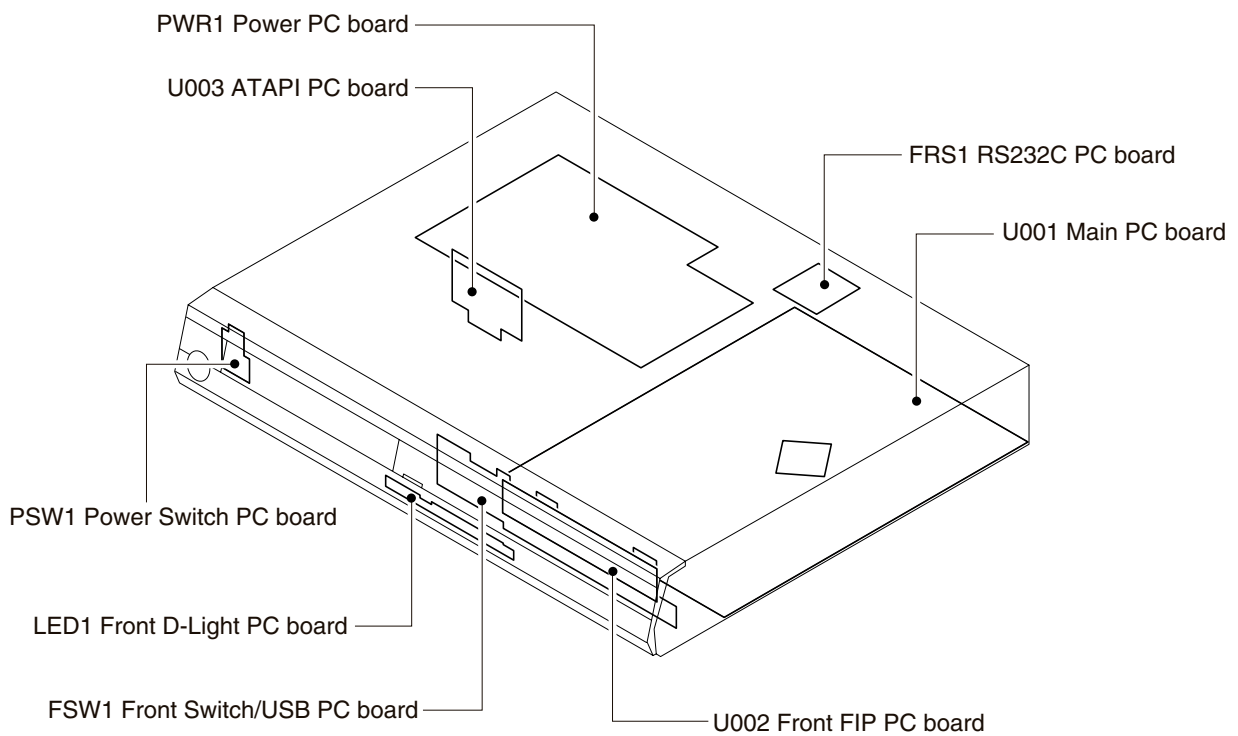

Fig. 1-2-2

SECTION 2

PART REPLACEMENT PROCEDURES

CAUTIONS BEFORE STARTING PART REPLACEMENT

Electronic parts are susceptible to static electricity and may easily be damaged, so do not forget to ground as required. Many screws are used inside the unit. To prevent the screws from missing or dropping, etc. always use a magnetized screwdriver in servicing. Several kinds of screws are used and some of them need special cautions. That is, take care of the tapping screws securing molded parts and fine pitch screws used to secure metal parts. If they are used improperly, the screw holes will be easily damaged and the parts can not be fixed.

1. REPLACEMENT OF MECHANICAL PARTS

Note:

- Circled numbers in the figure show the main disassembly procedure. Refer to them when disassembling.

1-1. Front Panel, Front PC Boards

Note: Do not tighten up the screws **16** too much.
(Tightening torque: 1.0kg • cm (0.098N • m))

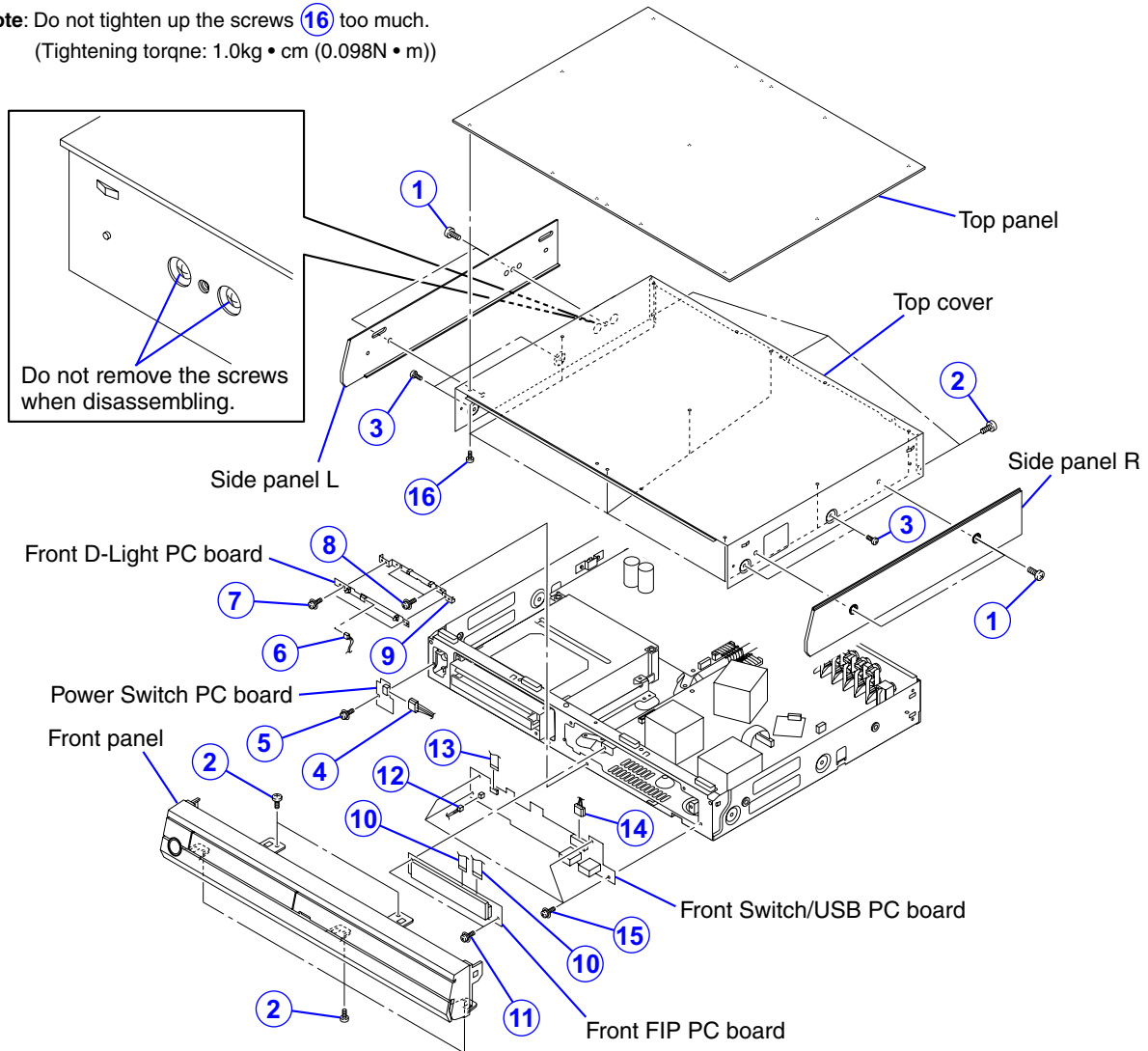

Fig. 2-1-1

1-2. Main/Power PC Boards

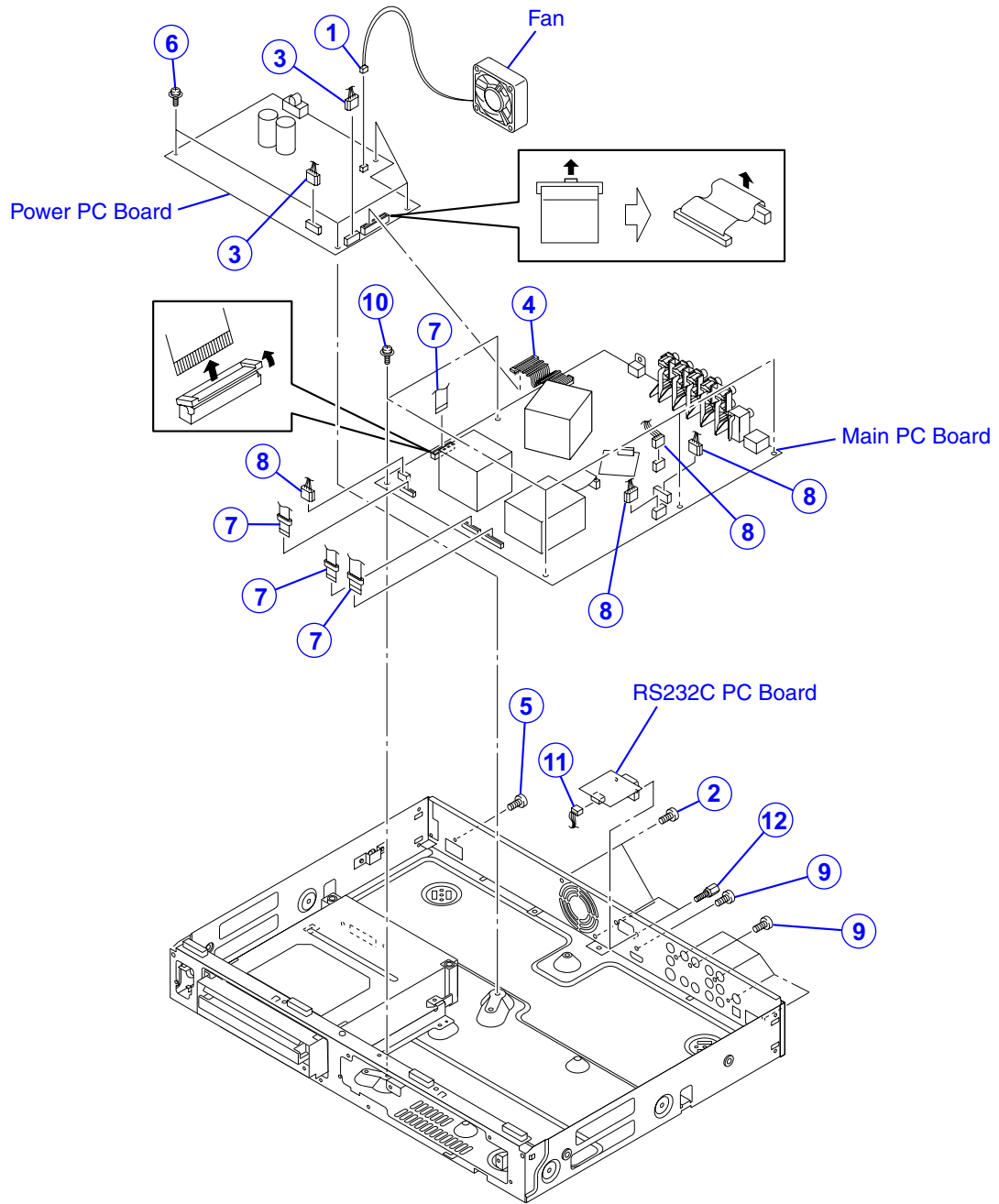

Fig. 2-1-2

1-3. DVD Drive

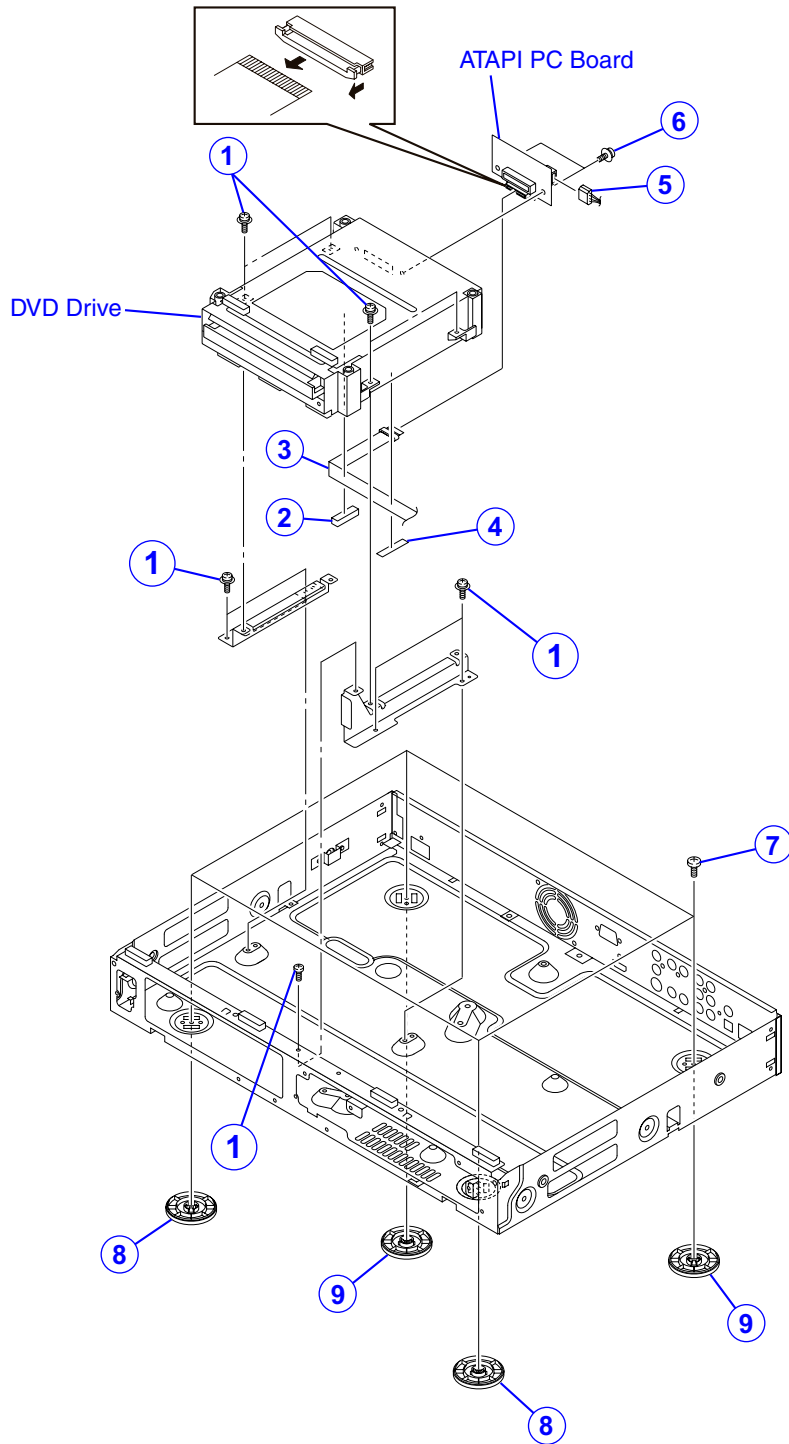

Fig. 2-1-3

2. WIRING CONNECTION DIAGRAM

2-1. Wiring Connection Diagram

After the servicing is complete, return the wiring to its original state by using the diagram below as a reference.

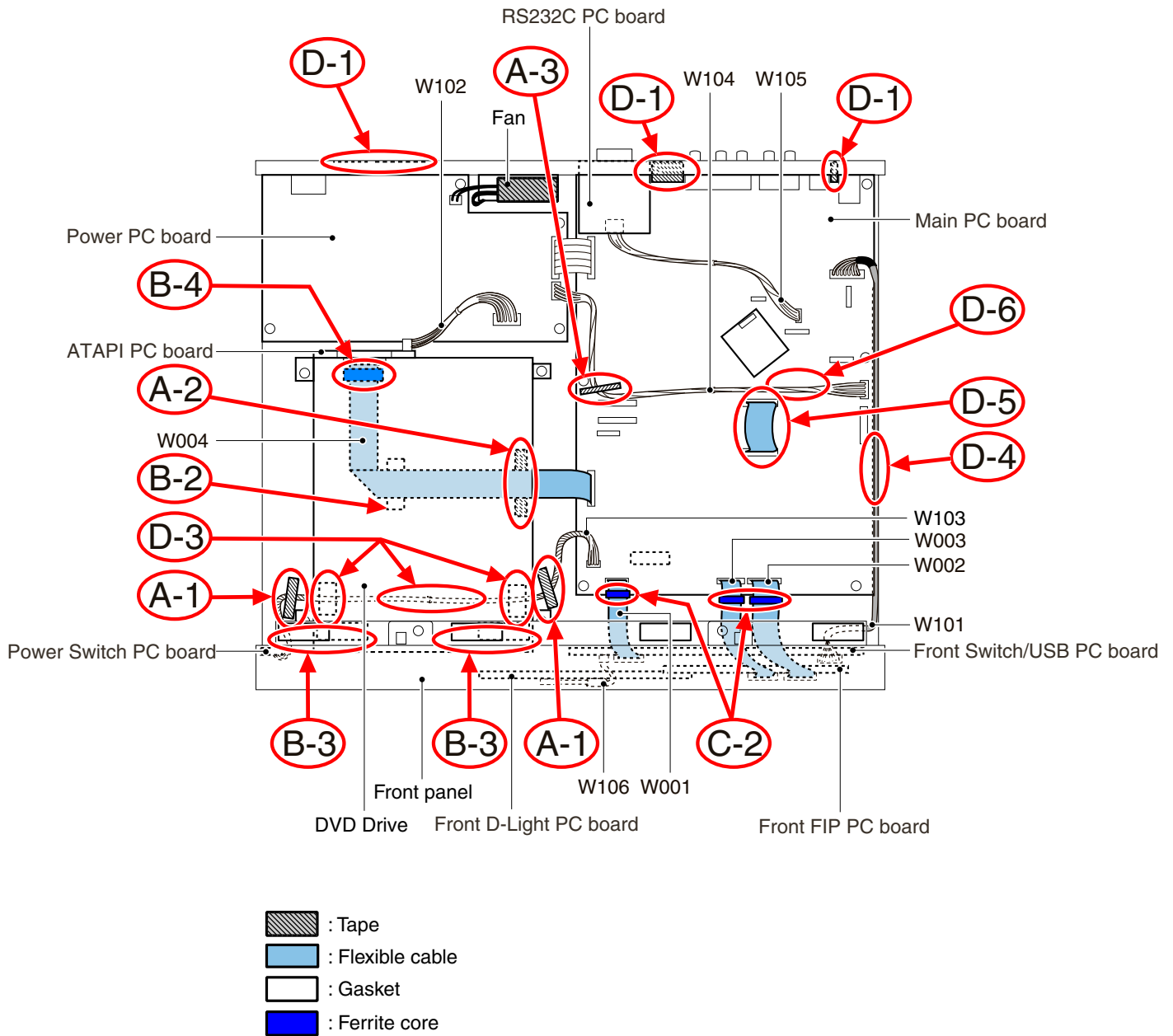
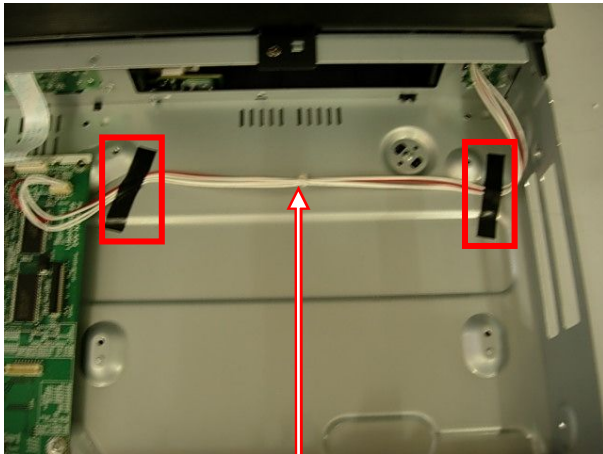

Fig. 2-2-1

2-2. Supplementary Instructions for Reassembling

A-1. Fix the wire (W103) with two tapes (TAPE-PET-W10-L50).

A-2. Fix the FFC (W104) with the tape (TAPE-PET-W10-L50).



W103

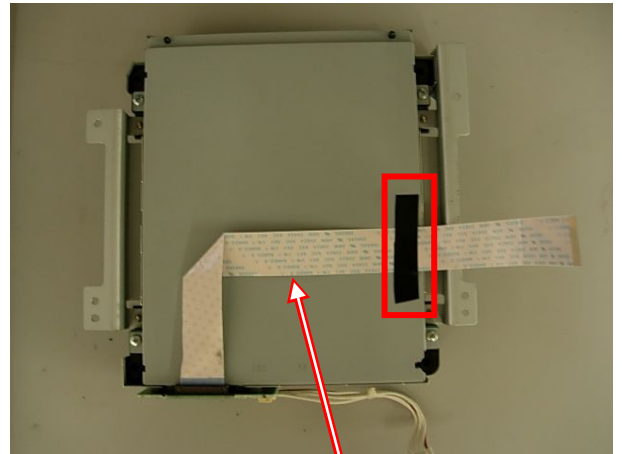

W104

A-3. Fix the wire (W004) with the tape (TAPE-PET-W10-L50).

(Fixed position : Between CN405 and C60D)

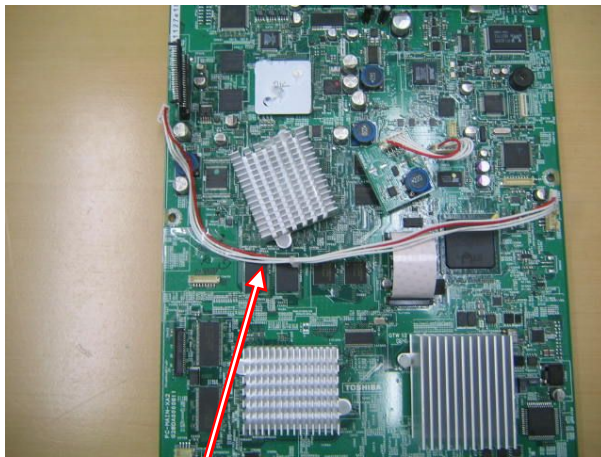

W004

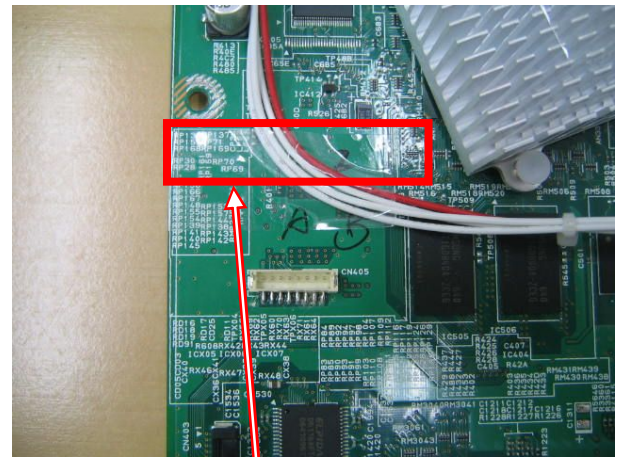

Fix (Between CN405 and C60D)

B-1. Paste the gasket to 4 places of the upper surface of front panel.

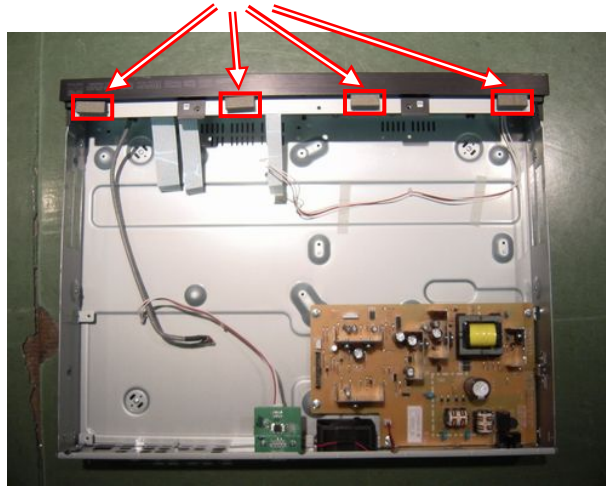

B-2. Paste gaskets to the following positions in the lower side of DVD drive.

(Gasket : SSTG10-10 L25HC(GD9D0000080))

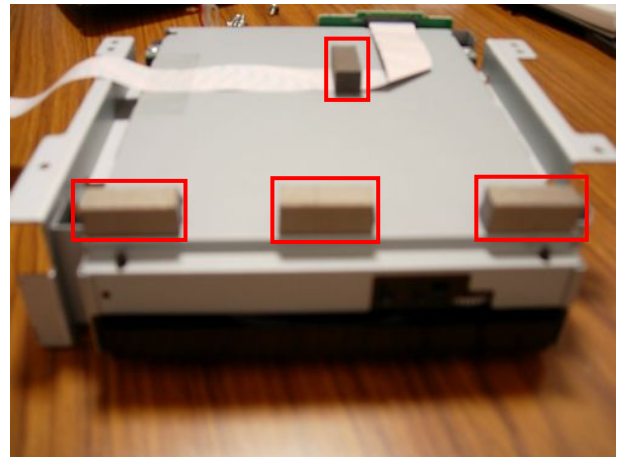
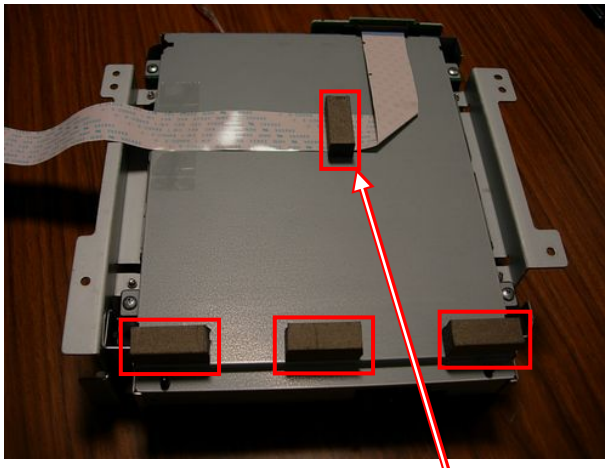

Paste the gasket just behind folded FFC.

B-3. Paste gaskets to the following positions in the upper side of DVD drive.

(Gasket : SSTG10-10 L25HC(GD9D0000080))



Paste gasket to the position where a semicircle part of the hole of molde this DVD drive correspond to the edge of Gasket.

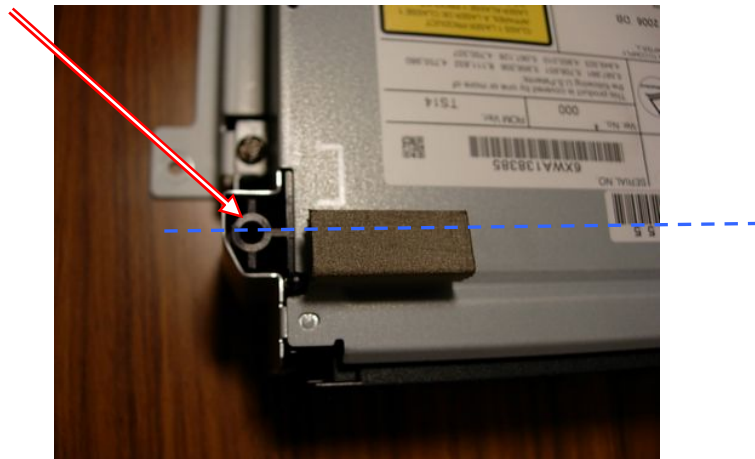

B-4. Attach ferrite core (HF70SH22*0.8*7 : PM0009691010) to FFC between DVD drive and main board.

(fixed position : just behind PC board side of DVD drive, Use TAPE-PET-W10-L50)

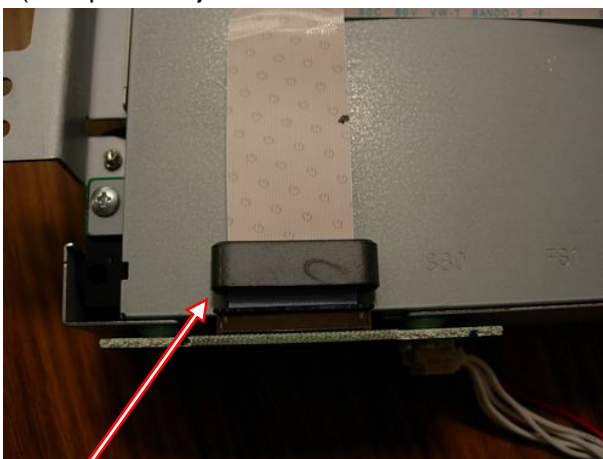

ferrite core (HF70SH22*0.8*7 : PM0009691010)

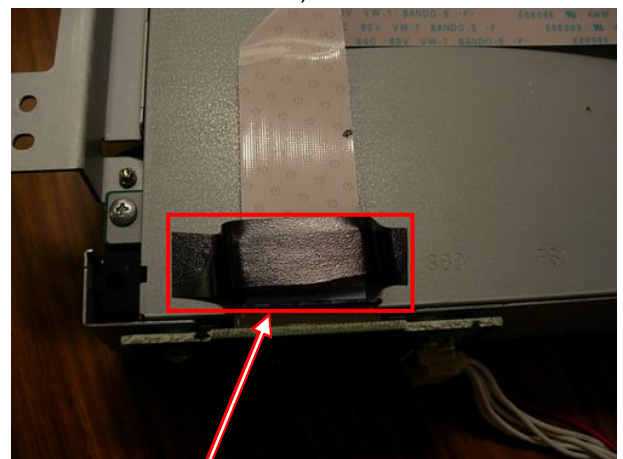

TAPE-PET-W10-L50

C-1. Attach ferrite core Z001F(PM0007982010:ZCAT2132-1130) to the power code. Roll the power code twice.
(HD-XE1KE has two power codes. Attach ferrite core on each power code.)

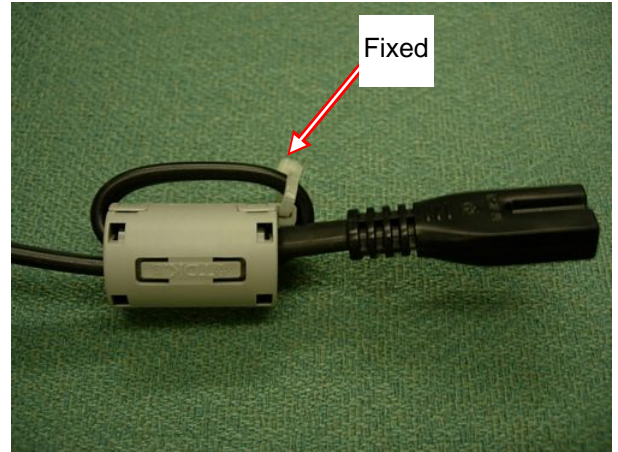

C-2. Attach ferrite cores(HF70SH22*0.8*7:PM0009691010) for FFC(W001,W002,W003) of between Front and Main.
Fix three cores with the tape respectively (TAPE-PET-W10-L50).
(Fixed position : Main side)

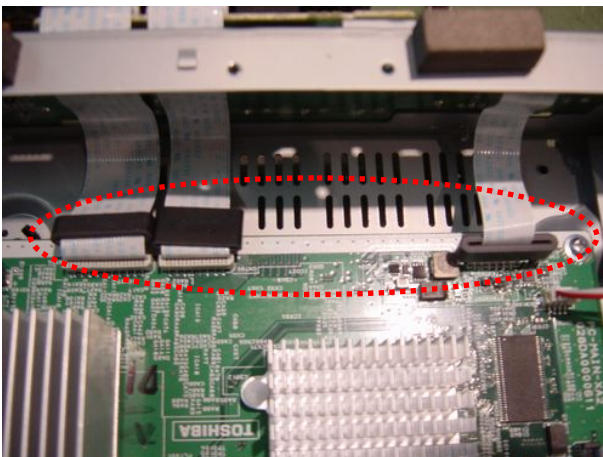

C-3. Fix right and left both sides of top cover with the screw. (Screw : BITTS 3x6)

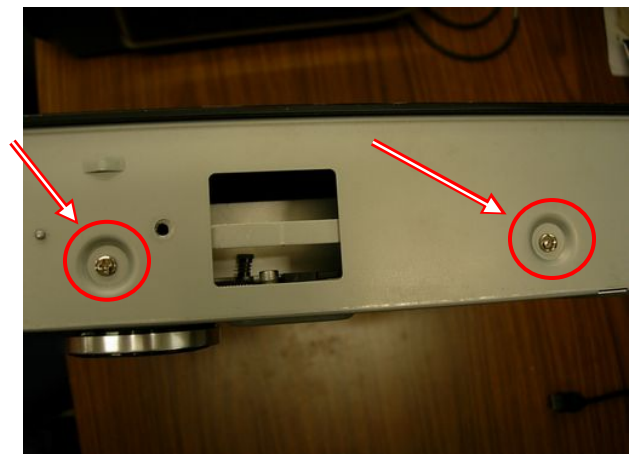
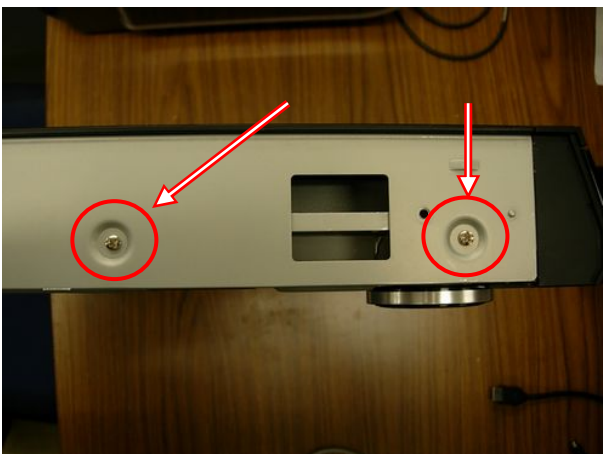

D-1.Paste the aluminum tapes to the position of A, B, and C.

Position A : 25mm(Tape Width) X 30mm

Position B : 25mm(Tape Width) X 50mm

Position C : 25mm(Tape Width) X 7mm

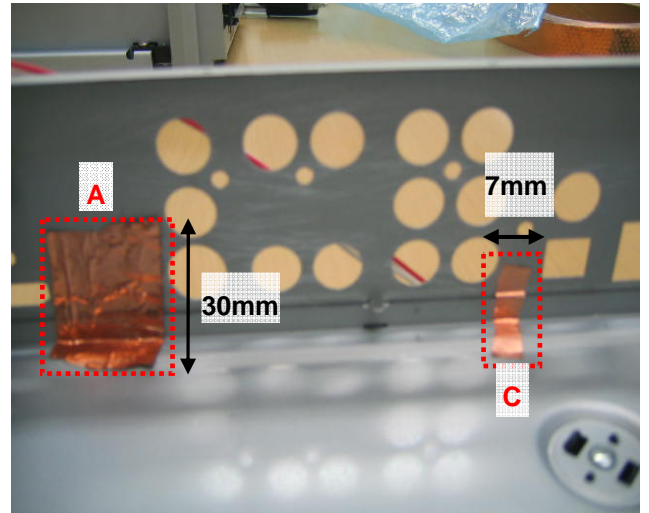
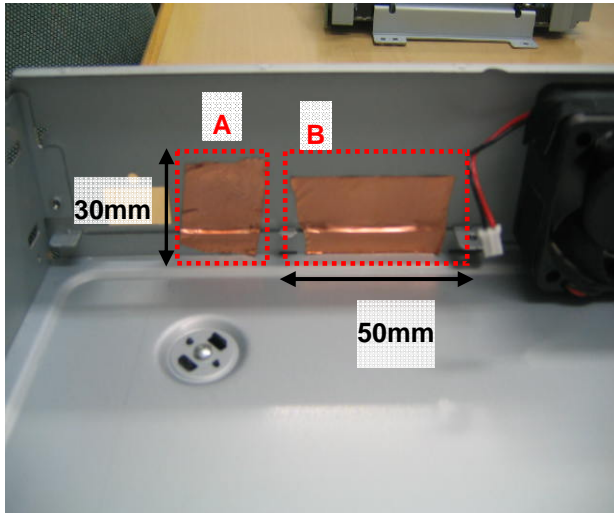

D-2.Twist W103.

D-3.Fix the wire (W103) to the following position (A and B) with two aluminum tapes (GY4D00000030, Parts Name: AL-25T, Tape Width : 40mm).

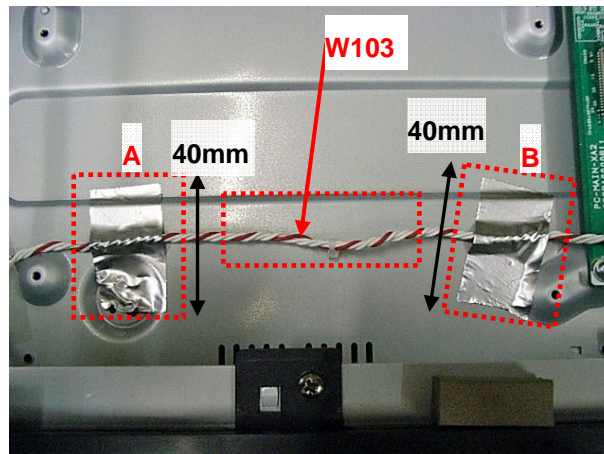

D-4.Insert the USB wire (W101) to the space of main unit and chassis.

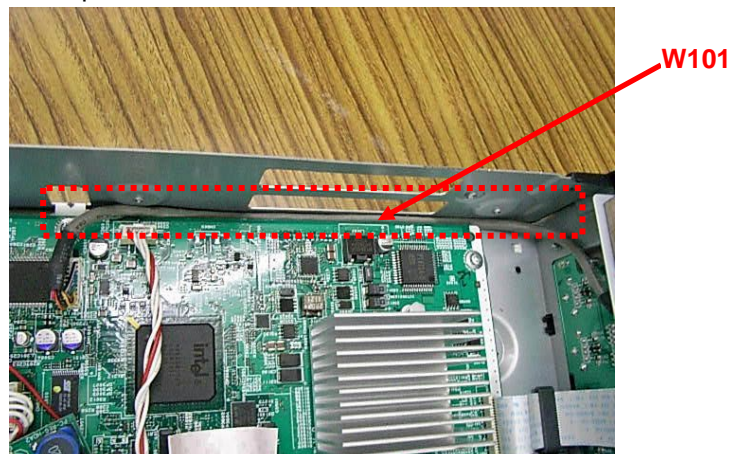

D-5.Press W005 to PCB side.

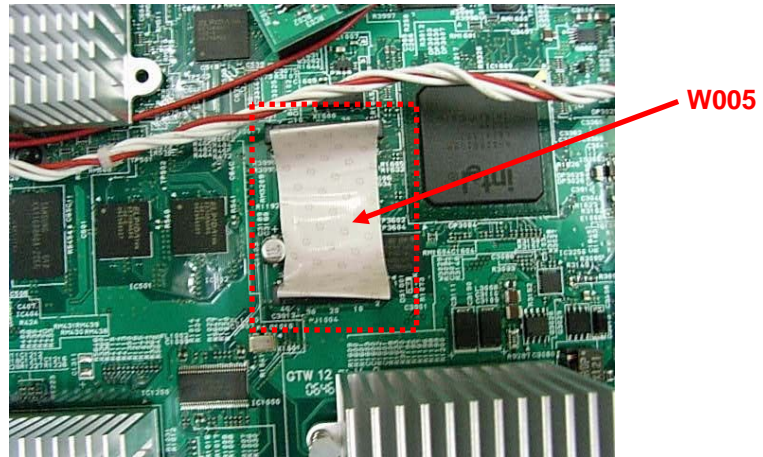

D-6.Twist W104.

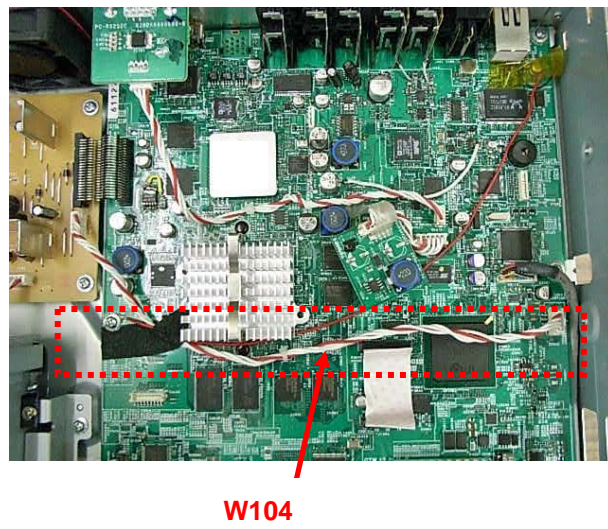

1-4. Inductor Indication

Unit	None H μ μH m mH
Tolerance	None ±5% B ±0.1% C ±0.25% D ±0.5% F ±1% G ±2% K ±10% M ±20%

Eg. 4

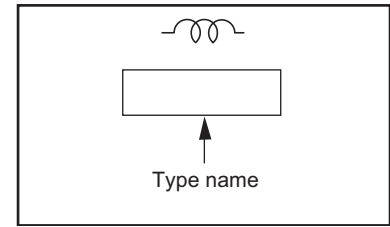

Fig. 3-1-4

1-5. Waveform and Voltage Measurement

- The waveforms for CD/DVD and RF shown in the circuit diagrams are obtained when a test disc is played back.
- All voltage values except the waveforms are expressed in DC and measured by a digital voltmeter.

1-6. Others

- The parts indicated with "NC" or "KETU" etc. are not used in the circuits of this model.

Eg. 5

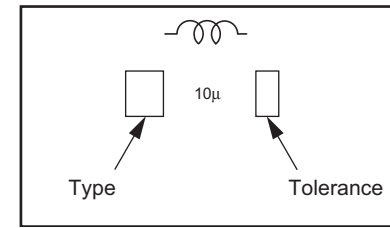

Fig. 3-1-5

2. PRINTED WIRING BOARD AND SCHEMATIC DIAGRAM

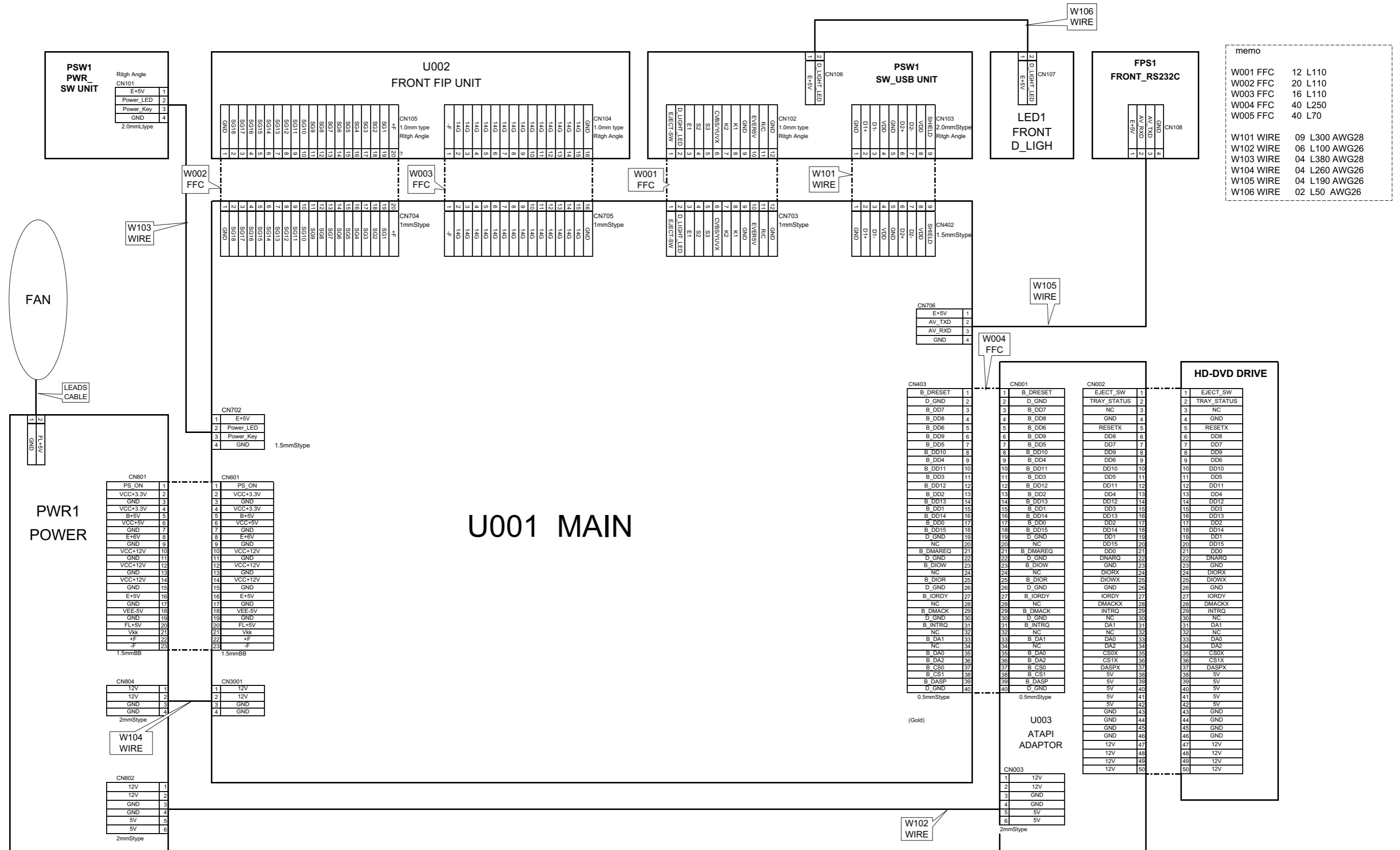

Fig. 3-2-1

3. BLOCK DIAGRAMS

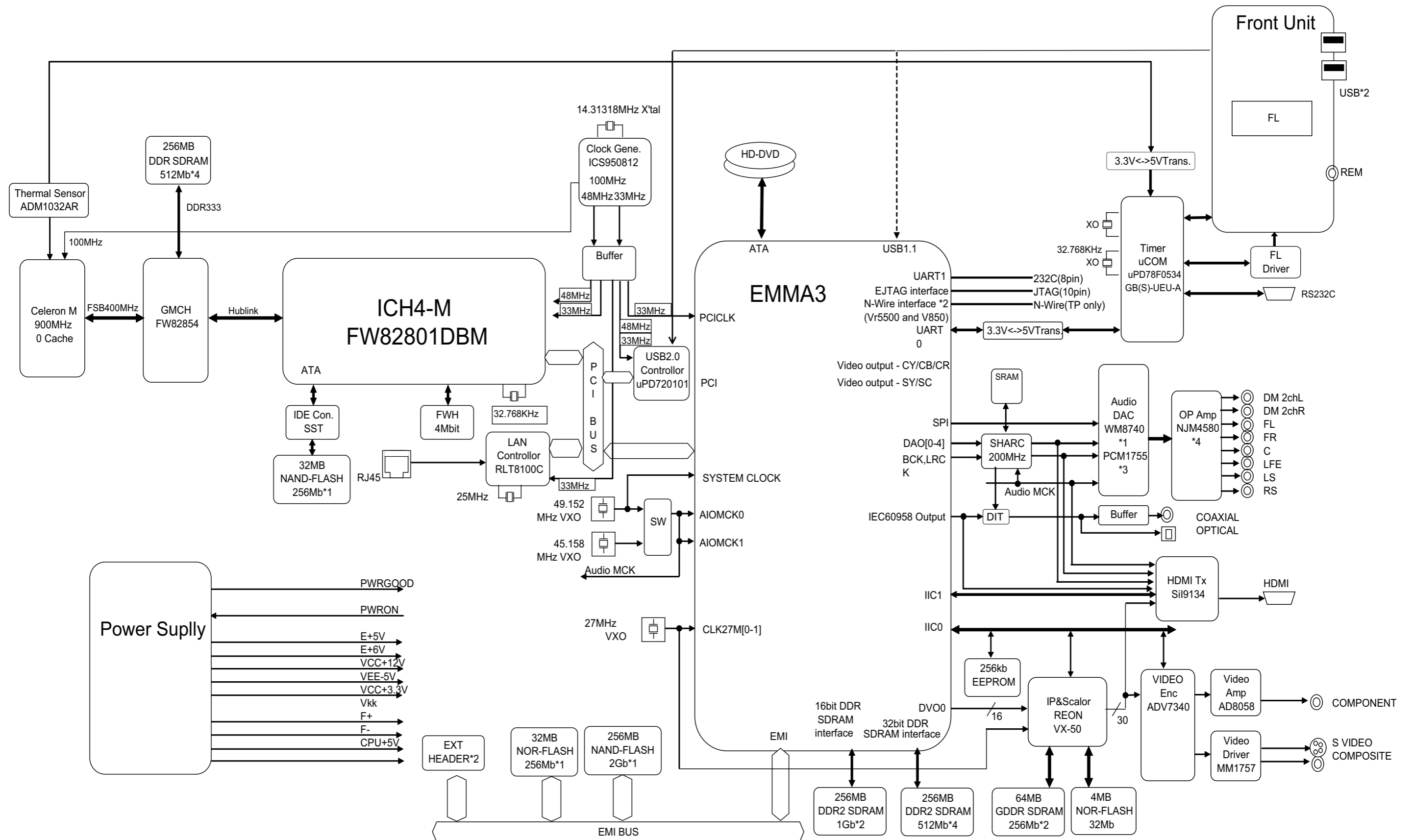

Fig. 3-3-1

4-2. Front Circuit Diagram

4-2-1. Front FIP Circuit Diagram

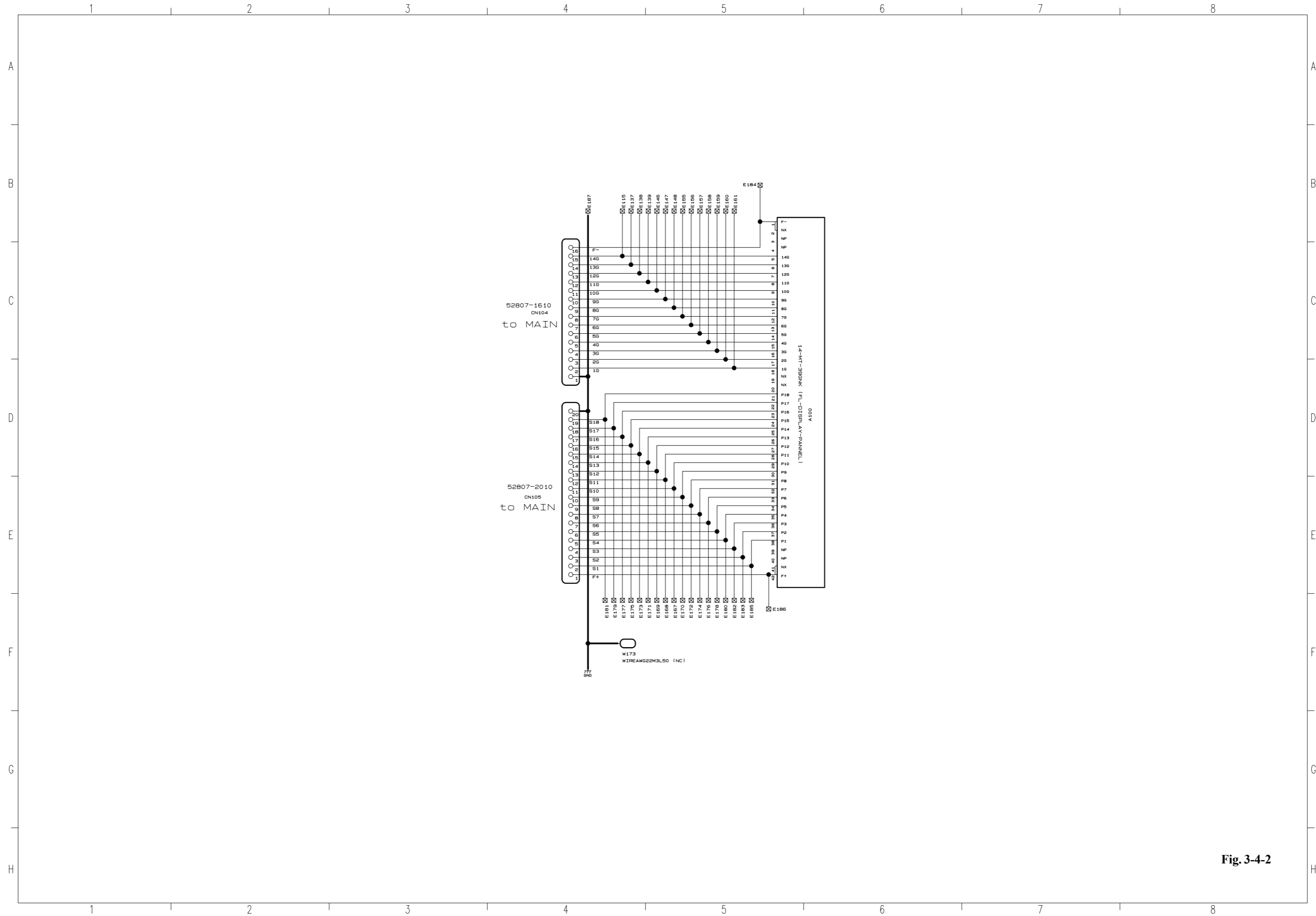

Fig. 3-4-2

4-2-2. Power Switch Circuit Diagram

D121	Not use
D122	Use

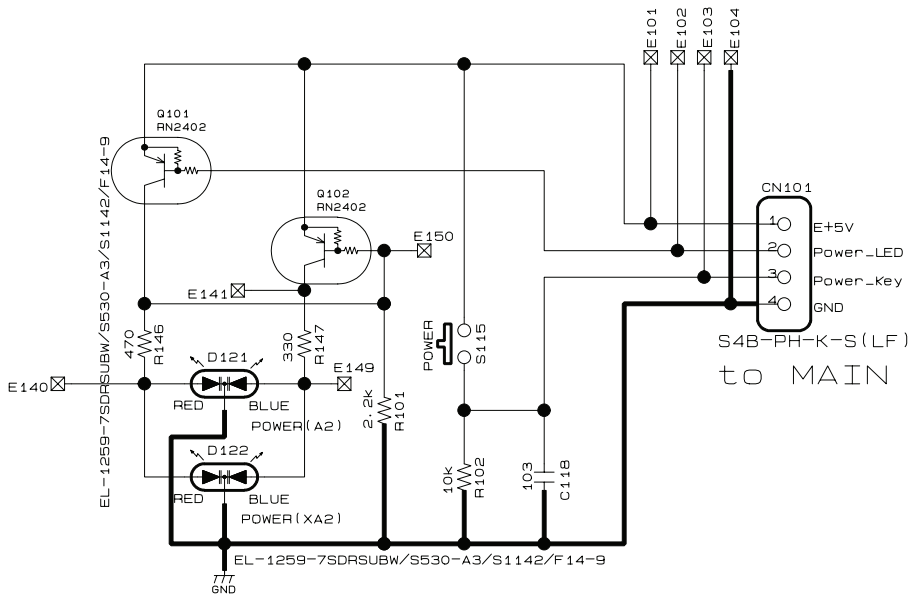

Fig. 3-4-3

4-2-3. Front Switch/USB Circuit Diagram

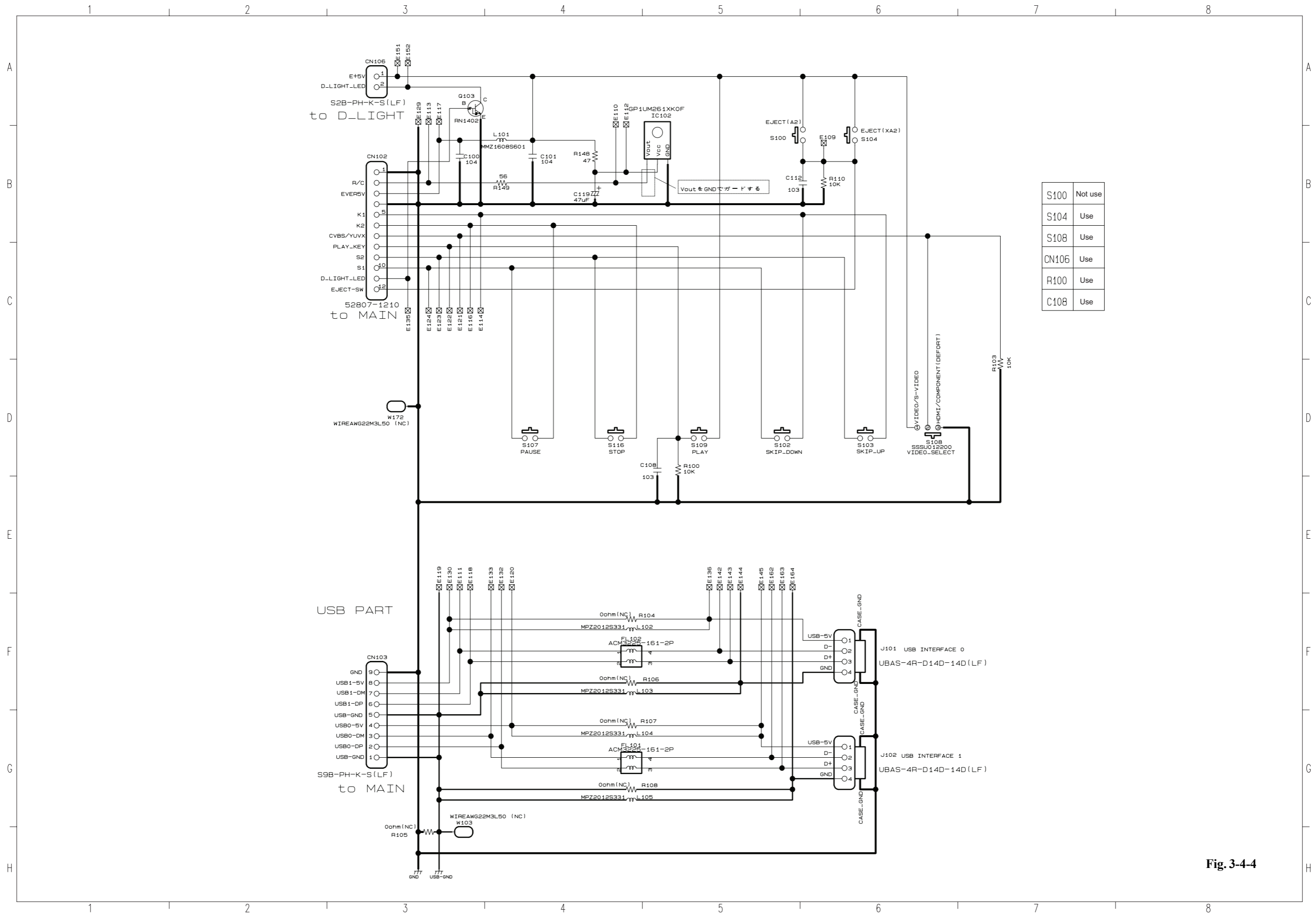

Fig. 3-4-4

4-2-4. Front D-Light Circuit Diagram

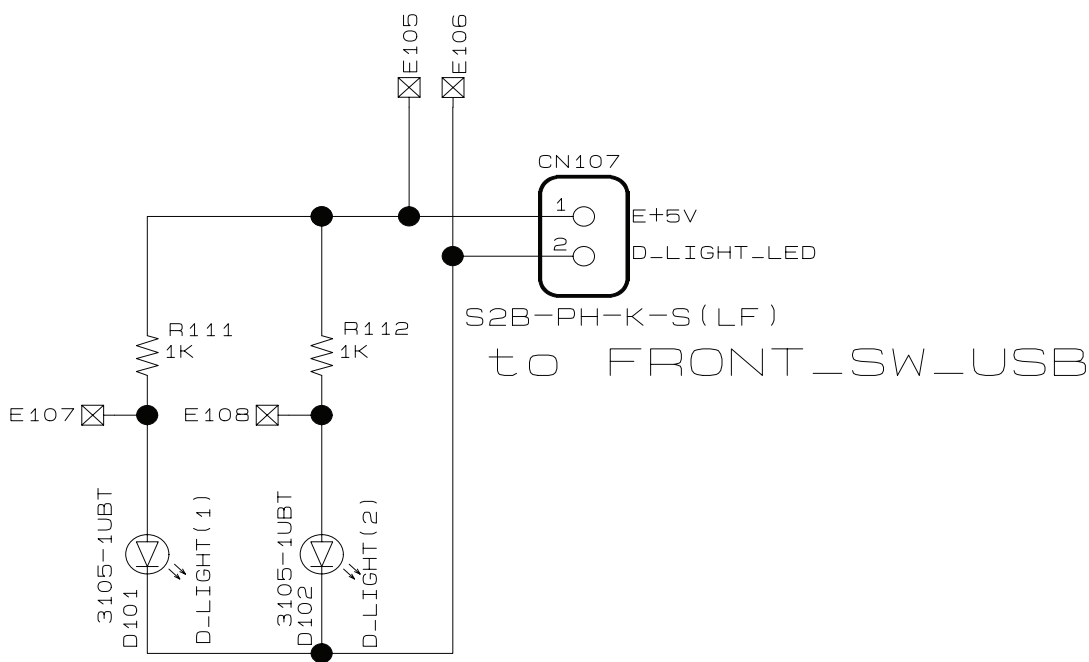

Fig. 3-4-5

4-3. RS232C Circuit Diagram

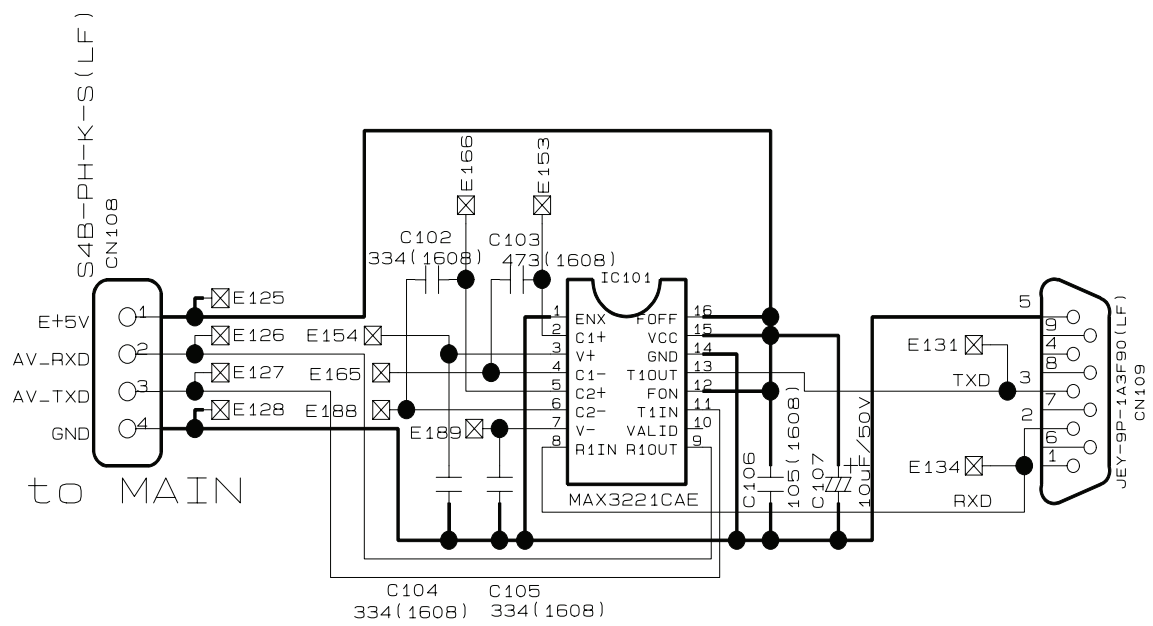
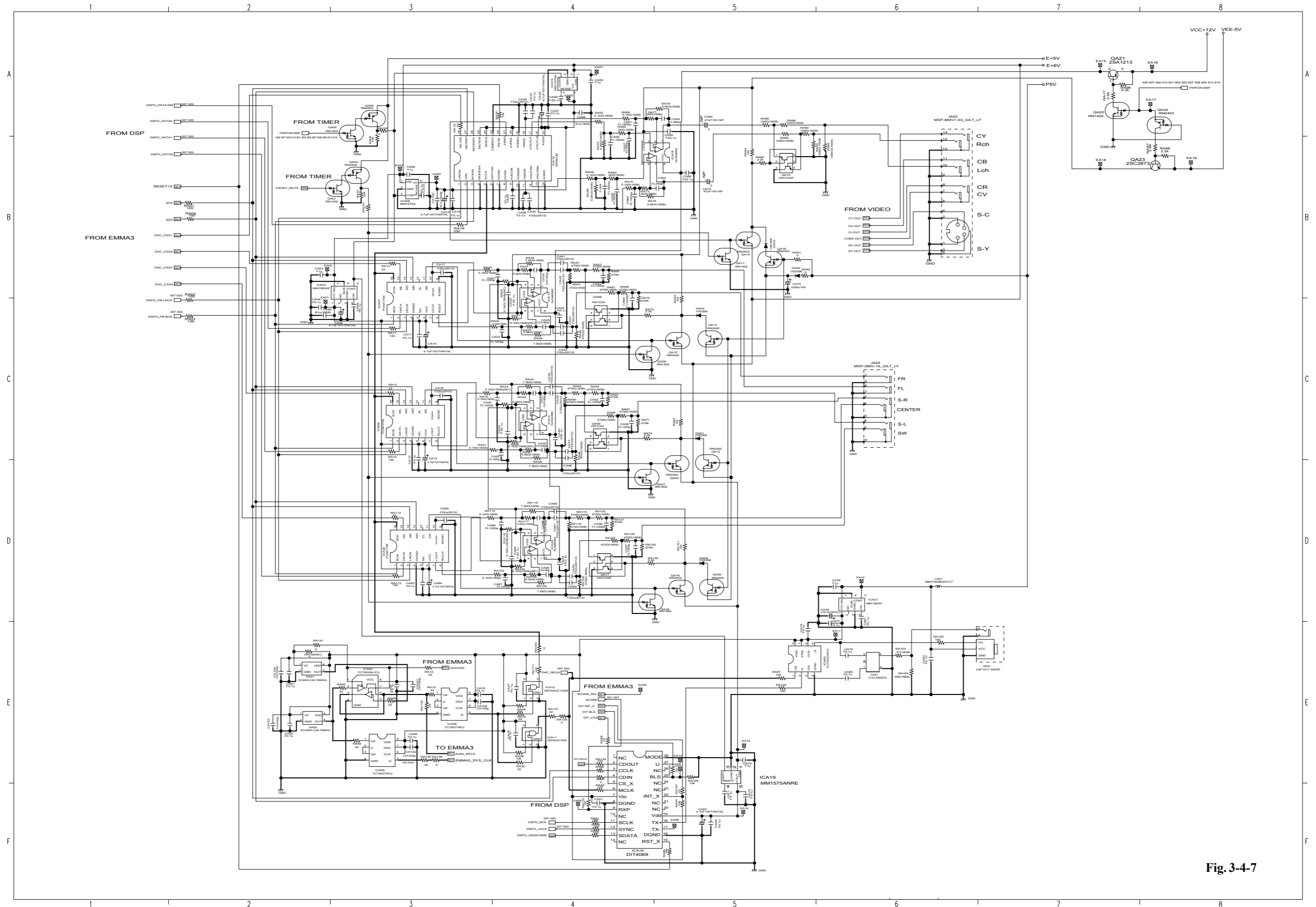

Fig. 3-4-6

4-4. Main Circuit Diagram

4-4-1. AV Output Circuit Diagram

Note : The main circuit diagrams describe only part of information.



4-4-2. Timer Circuit Diagram

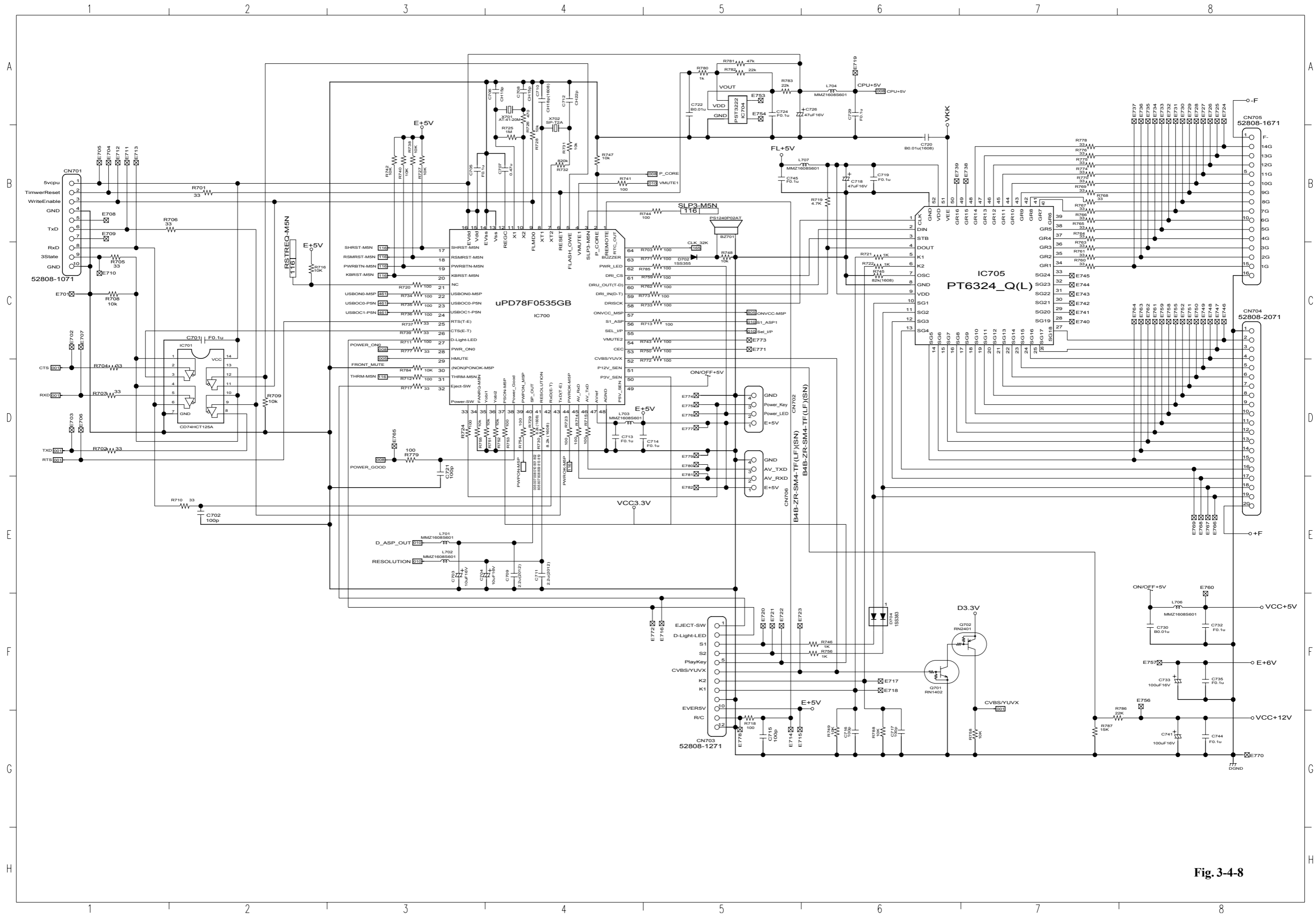

Fig. 3-4-8

4-4-3. Video Scaller Circuit Diagram

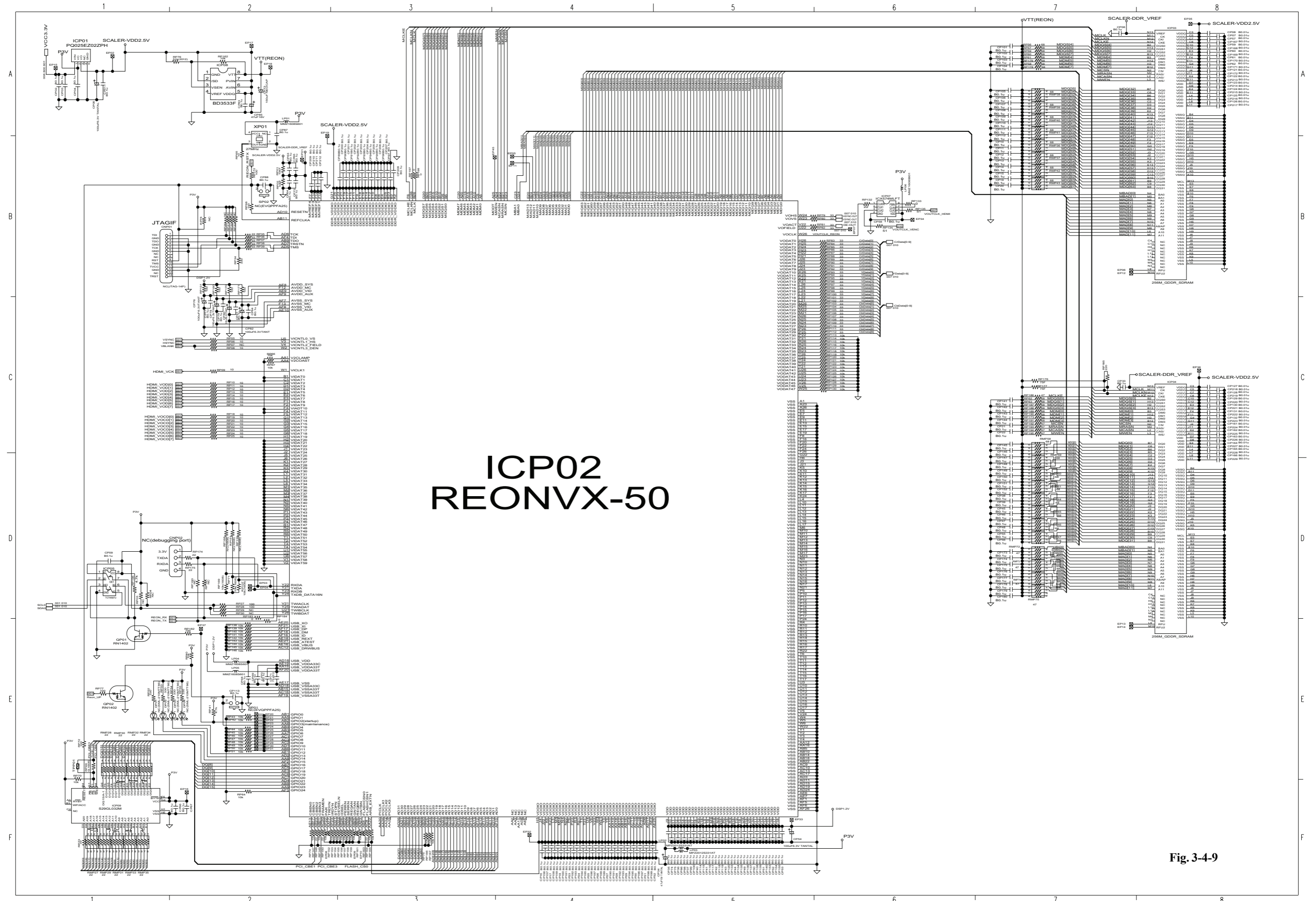

Fig. 3-4-9

4-4.4. Video Output Circuit Diagram

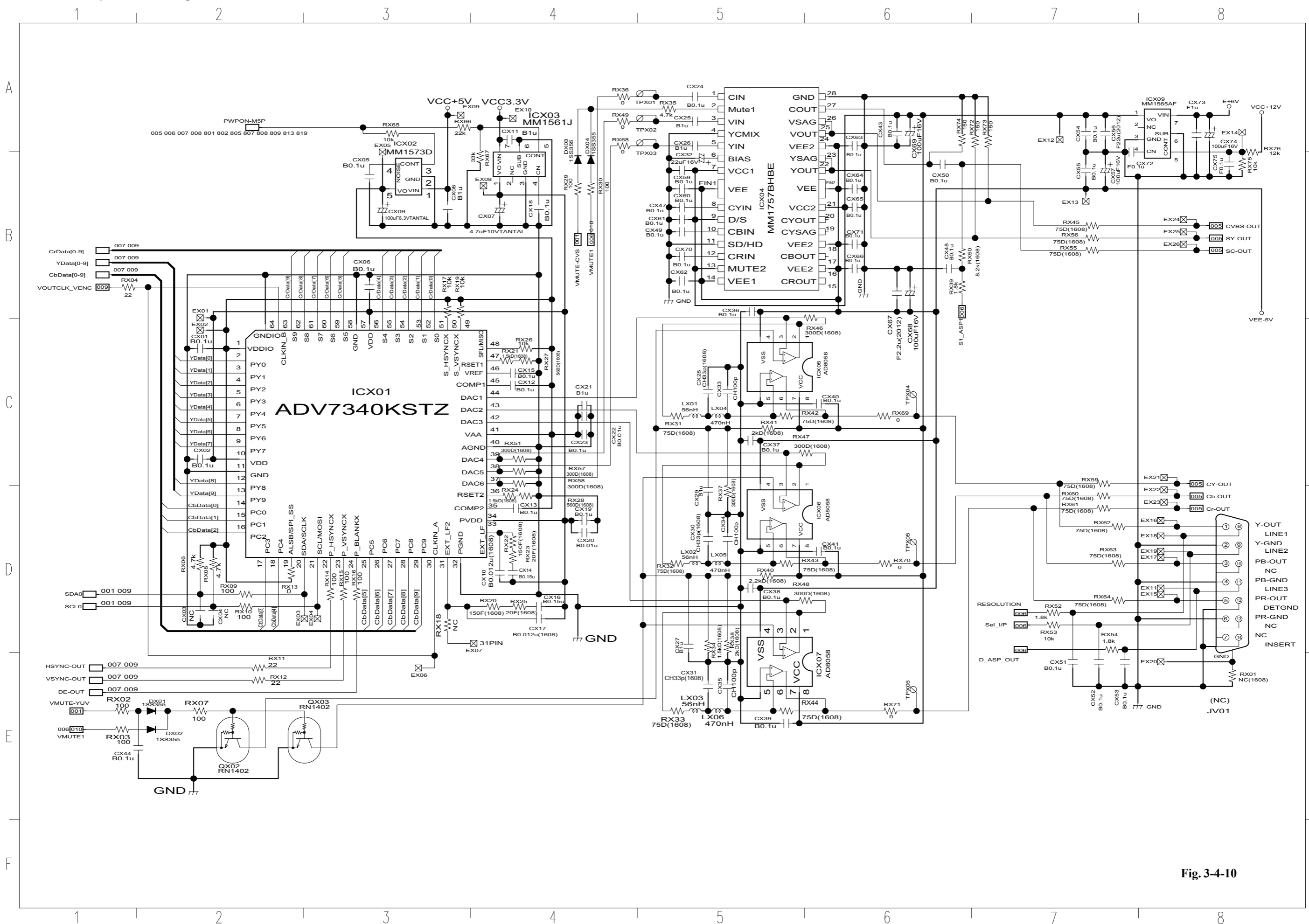

Fig. 3-4-10

4-5. ATAPI Conversion Circuit Diagram

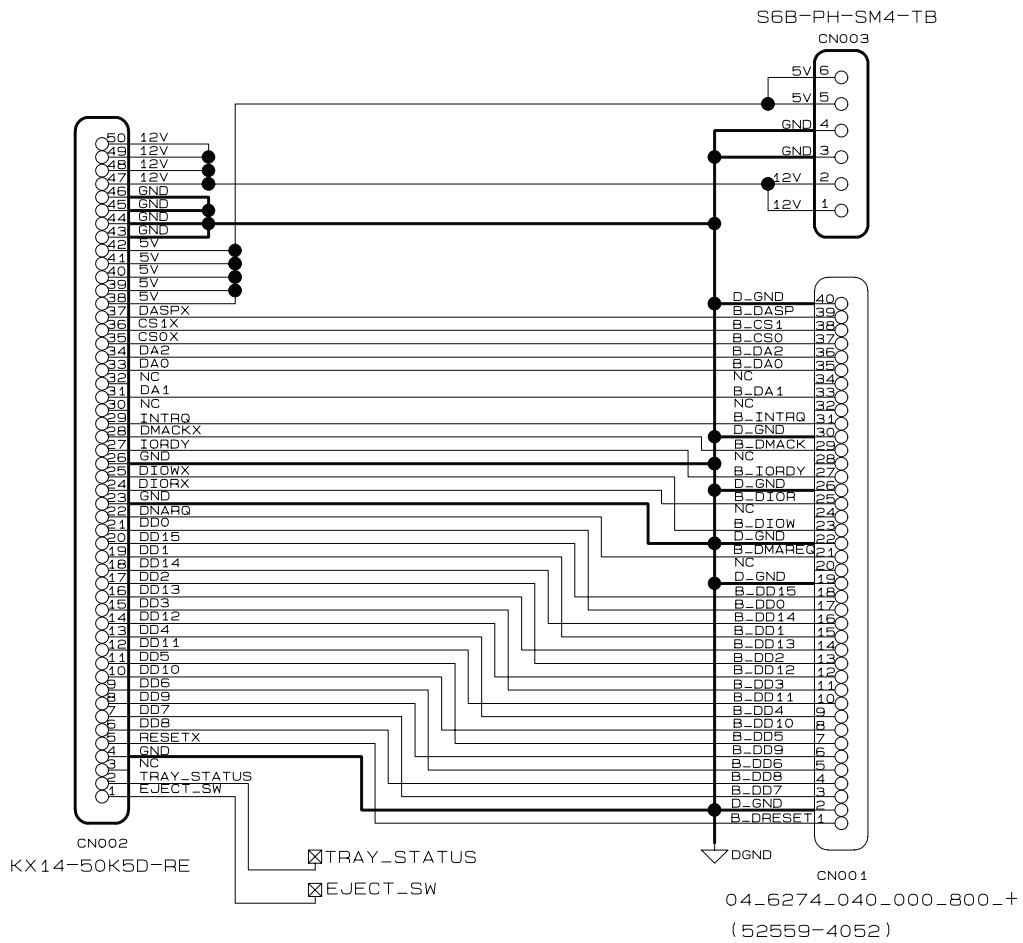

Fig. 3-4-11

5. PC BOARDS

5-1. Front FIP PC Board

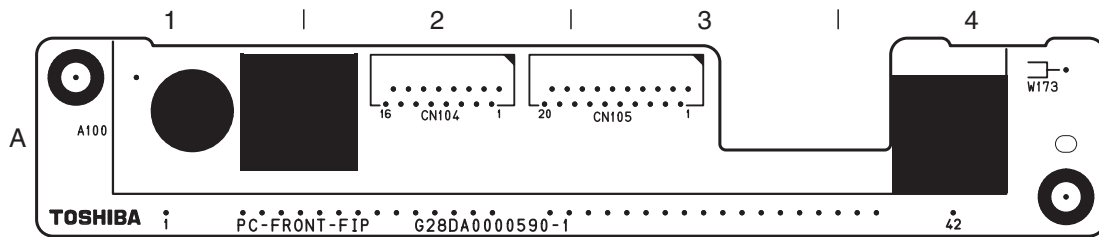

Fig. 3-5-1 Front FIP PC Board (Top side)

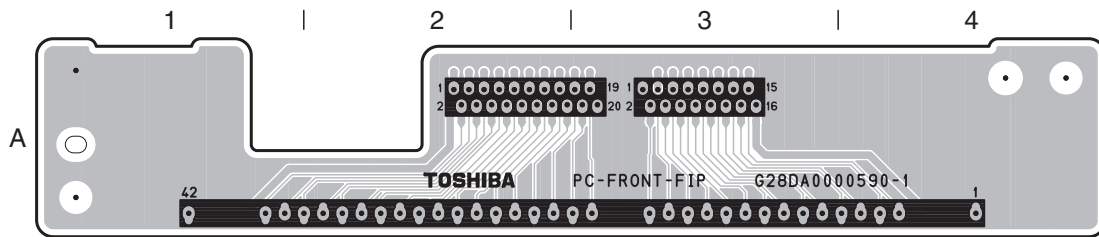

Fig. 3-5-2 Front FIP PC Board (Bottom side)

5-2. Power Switch PC Board

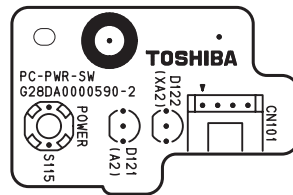

Fig. 3-5-3 Power Switch PC Board (Top side)

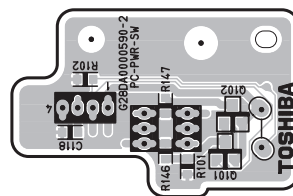

Fig. 3-5-4 Power Switch PC Board (Bottom side)

5-3. Front Switch/USB PC Board

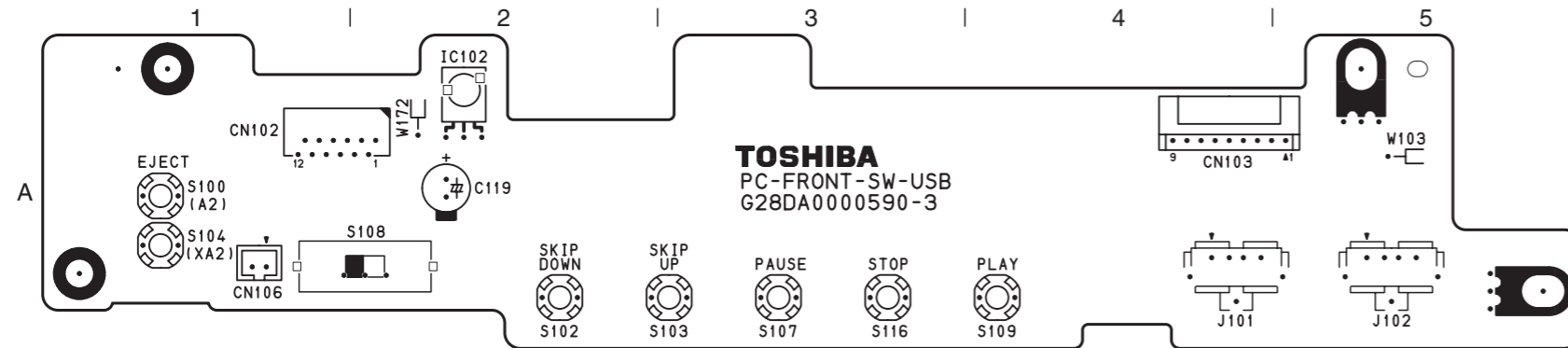

Fig. 3-5-5 Front Switch/USB PC Board (Top side)

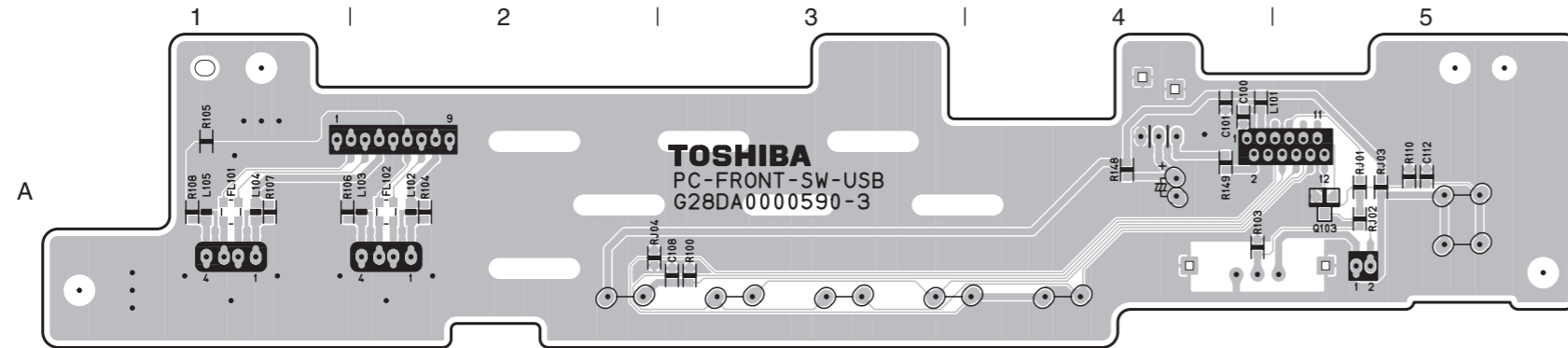

Fig. 3-5-6 Front Switch/USB PC Board (Bottom side)

5-4. ATAPI PC Board

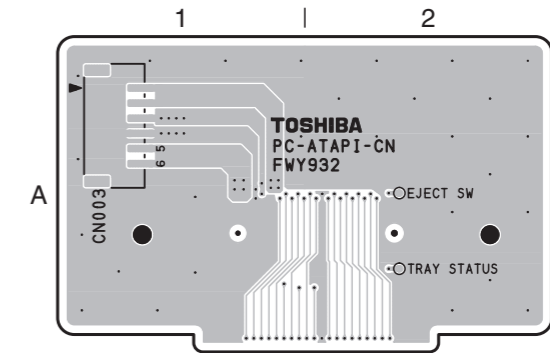

Fig. 3-5-7 ATAPI PC Board (Top side)

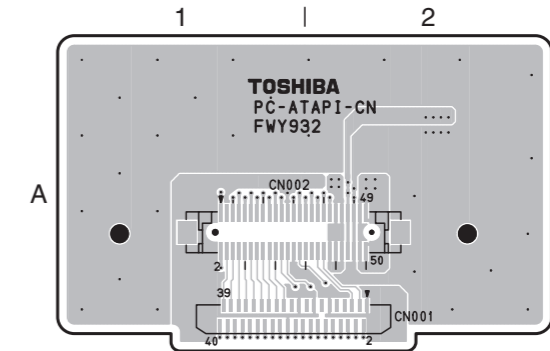

Fig. 3-5-8 ATAPI PC Board (Bottom side)

1

2

3

4

5

5-5. D-Light PC Board

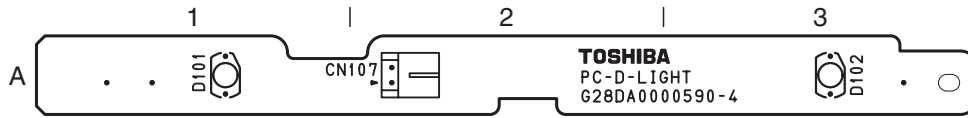

Fig. 3-5-9 D-Light PC Board (Top side)

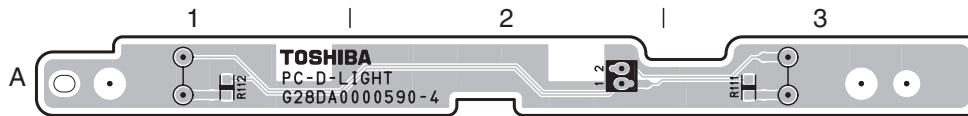

Fig. 3-5-10 D-Light PC Board (Bottom side)

5-6. RS232C PC Board

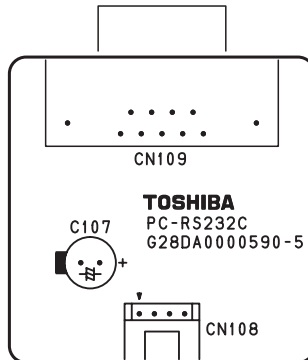

Fig. 3-5-11 RS232C PC Board (Top side)

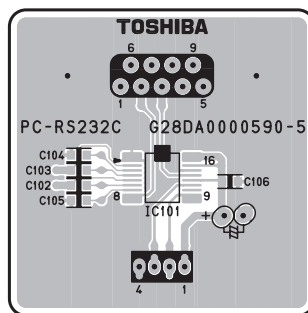

Fig. 3-5-12 RS232C PC Board (Bottom side)

SECTION 4 PARTS LIST

SAFETY PRECAUTION

The parts identified by ! (Δ) mark are critical for safety. Replace only with part number specified.

The mounting position of replacement is to be identical with originals.

The substitute replacement parts which do not have the same safety characteristics as specified in the parts list may create shock, fire or other hazards.

NOTICE

The part number must be used when ordering parts in order to assist in processing, be sure to include the model number and description.

ABBREVIATIONS

- **Integrated Circuit (IC)**
- **Capacitor (Cap)**
 - **Capacitance Tolerance (for Nominal Capacitance more than 10pF)**

Table 4-2-1

Symbol	B	C	D	F	G	J	K	M	N
Tolerance %	±0.1	±0.25	±0.5	±1	±2	±5	±10	±20	±30

Symbol	P	Q	T	U	V	W	X	Y	Z
Tolerance %	+100 0	+30 -10	+50 -10	+75 -10	+20 -10	+100 -10	+40 -20	+150 -10	+80 -20

Ex. 10 μ F J = 10 μ F ± 5%

- **Capacitance Tolerance (for Nominal Capacitance 10pF or less)**

Table 4-2-2

Symbol	B	C	D	F	G
Tolerance pF	±0.1	±0.25	±0.5	±1	±2

Ex. 10pF G = 10pF ± 2pF

- **Resistor (Res)**
 - **Resistance tolerance**

Table 4-3-1

Symbol	B	C	D	F	G	J	K	M
Tolerance %	±0.1	±0.25	±0.5	±1	±2	±5	±10	±20

Ex. 470 Ω J = 470 Ω ± 5%

1. EXPLODED VIEWS
1-1. Packing Assembly

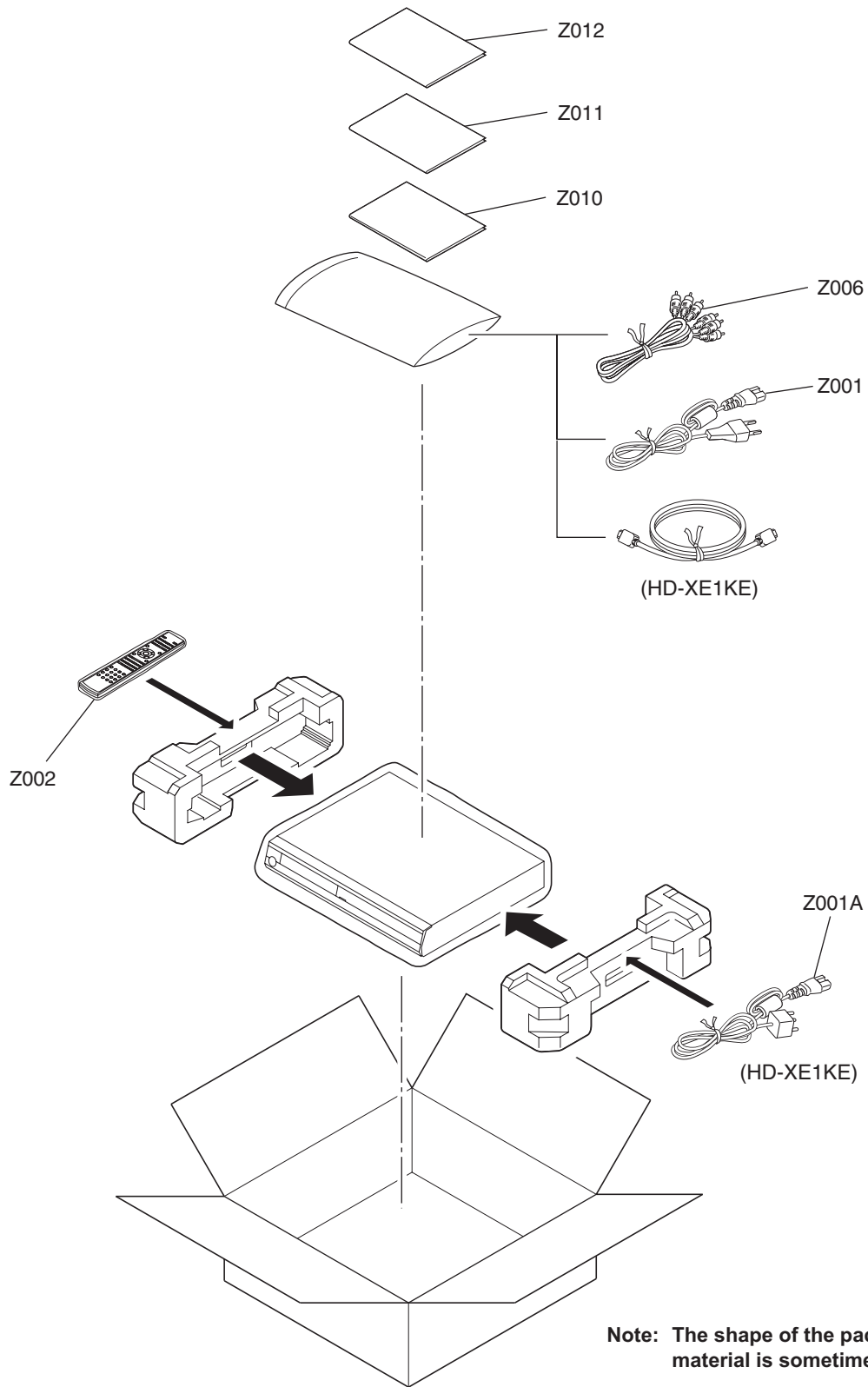

Fig. 4-1-1

1-2. Chassis Assembly

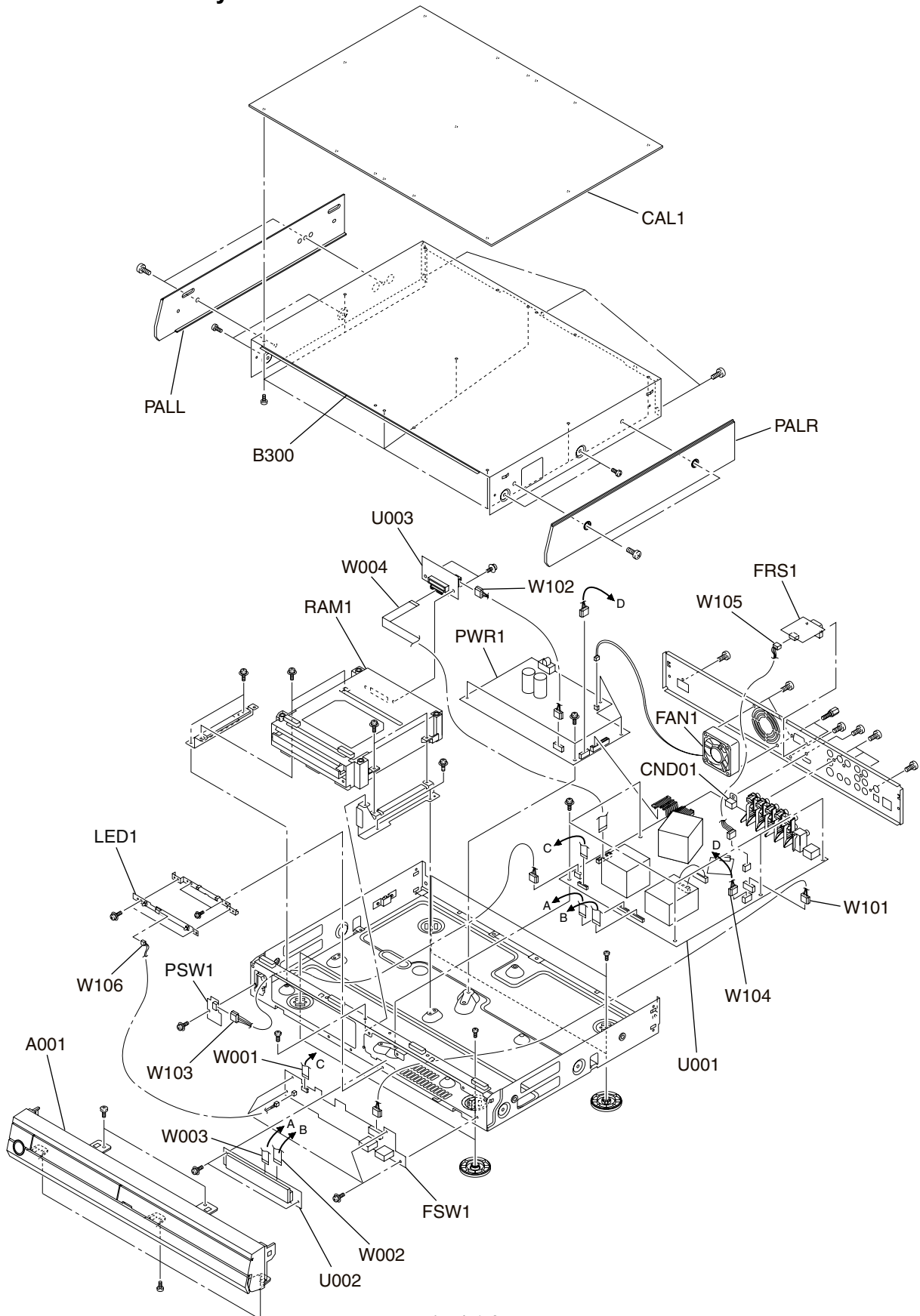

Fig. 4-1-2

2.PARTS LIST

Location No.	Part No.	Description	
- ELECTRICAL PARTS -			
U001	P000479350	PC BOARD ASSY MAIN	
CND01	P000480920	HDMI JACK,DC1R019JBE	
U002	P000479080	PC BOARD ASSY FRONT-FIP	
U003	P000477350	ATAPI-FFC ADAPTER	
⚠ PWR1	P000479360	POWER-UNIT, MPN51115P	
FSW1	P000479100	PC BOARD ASSY FRONT-SW	
LED1	P000479340	PC BOARD ASSY FRONT-LED	
PSW1	P000479210	PC BOARD ASSY POWER-SW	
FRS1	P000479330	PC BOARD ASSY RS232C	
- MECHANICAL PARTS -			
A001	P000479370	PANEL ASSY, FRONT	
CAL1	P000479180	COVER, AL-TOP	
FAN1	P000479120	FAN, DC DSB0512LD-6V36	
PALL	P000479190	PANEL, AL-SIDE-L	
PALR	P000479200	PANEL, AL-SIDE-R	
⚠ RAM1	P000477500	HD-DVD-DRIVE, SD-E802A	
W001	P000477420	FFC-12P-L102 MAIN-FRONT	
W002	P000477430	FFC-20P-L102 MAIN-FRONT	
W003	P000477440	FFC-16P-L102 MAIN-FRONT	
W004	P000477450	FFC-40P-L242 MAIN-DRIVE	
W101	P000477530	WIRE CABLE ZHR-9P-L300 MAIN-USB	
W102	P000477540	WIRE CABLE PHR-6P-L100 POWER-ATAPI	
W103	P000477550	WIRE CABLE ZHR-4P-L380 MAIN-PWRSW	
W104	P000477560	WIRE CABLE PHR-4P-L260 MAIN-POWER	
W105	P000479150	WIRE CABLE PHR-4-AWG26-L190-ZHR-4	
W106	P000479160	WIRE CABLE PHR-2-AWG26-L50-PHR-2	
⚠ Z001	P000354930	CORD POWER, UK-SET	HD-XE1KE
⚠ Z001A	P000477770	CORD POWER, TE-SET	HD-XE1KE
⚠ Z001	P000480900	CORD POWER, TY-SET	HD-XE1KY
Z002	P000479140	REMOTE CONTROL, SE-R0251	
Z006	P000477520	AV CABLE, 3P-L1500	
⚠ Z010	P000477870	OWNERS MANUAL, ENGLISH	HD-XE1KE
⚠ Z011	P000477880	OWNERS MANUAL, FRENCH	HD-XE1KE
⚠ Z012	P000477860	OWNERS MANUAL, GERMAN	HD-XE1KE
⚠ Z011	P000480910	OWNERS MANUAL, ENGLISH	HD-XE1KY

SUPPLEMENT

SUPPLEMENT1. Firmware Version Update

We plan to respond to these developments by providing the firmware update.
The latest information will be informed Toshiba customer support on the WEB.

- 1) Main Firmware
- 2) HD DVD Drive Firmware

1. HD DVD Player FW Update

To update the firmware, the following procedures are provided.

1) HD DVD based

Internet connection Direct Download to player

2) CD-ROM

CD-ROM (mail)

2. Check Main Firmware version (in detail)

Check Main FW Version by the special Code from the remote control

<Field Service Use only — Do not disclose to users.>

- 1) Press "ON / STAND BY" on the unit or remote.
- 2) Press "DISPLAY" -> "1"->"9"->"5"-> "DISPLAY"
- 3) FW version is show on TV display as below.

Machine Code: *****
Submicom Version: *****
Group ID: **
Model ID: **
Package Version: 1000
NAND Version: ****
NOR Version: ****
WinCE Version: ****
FWH Version: ****
Drive Version: T17M

3. Firmware Version Check procedure

Check from "SET UP Menu"

- 1) Press "ON / STAND BY" on the unit or remote.
- 2) Press "SETUP" button.
- 3) Select "General" -> "Maintenance"->"Update".
- 4) The firmware version is shown on TV display as below.

Update
1.0/T17M
Would you like to continue
The update procedure?
[Yes] [No]

- 5) If select [Yes], downloading update will be started.

4. Firmware Update Procedure

(1) Main (or Drive) FW Update by CD-ROM disc

- 1) Insert Update disc into the unit.
- 2) Indicate the notice.
 - > Select YES & press "OK" button on the remote control.
- 3) Version update is started. Waiting a few minutes.
- 4) Tray will be opened and power off automatically.
- 5) Power On & confirm the FW version.

(2) FW Update from WEB site

From "SETUP" menu, the latest firmware can be downloaded to the unit.

- * Refer to Firmware version check procedure.
- * Internet always-on broadband connection is needed.

SUPPLEMENT2. Error Code

1. System Error

External Error Code								Content of Error	OSD	VFD
1	0	0	0	4	0	0	1	CPU Error		Error Code
2	0	0	0	C	0	0	1	No Disc	No Disc	Error Code
2	0	0	1	C	0	0	2	Disc Detection Error	Cannot play the disc. Check the disc.	Error Code
2	0	0	2	C	0	0	3	Not Support Disc	This disc is not DVD format. Cannot play the disc.	Error Code
2	0	0	3	C	0	0	4	PAL Contents Error	This disc is PAL. Cannot play the disc.	Error Code
2	0	0	4	C	0	0	5	NTSC Error	This disc is NTSC Cannot play the disc.	Error Code
2	0	0	5	C	0	0	6	Region Error	Region error	Error Code
2	0	0	D	C	0	0	7	Parental Error	Cannot play the disc due to parental lock.	Error Code
2	0	0	1	C	0	0	8	Disc Navigation Error	Cannot play the disc. Check the disc.	Error Code
2	0	1	9	C	0	0	9	ICT Warning	High resolution output is prohibited for this content. Resolution was changed to 480p.	Error Code
2	0	2	4	C	0	0	A	ICT Warning	High resolution output is prohibited for this content. Resolution was changed to 480p.	Error Code
2	0	2	5	C	0	0	B	DOT Warning	Analog output is prohibited. Change to HDMI output.	Error Code
2	0	2	2	C	0	0	C	Version Up Confirmation	Version Up ? [[Yes]] No	Error Code
2	0	2	0	C	0	0	D	Latest firmware no version up	The software has already been updated. The update process will end.	Error Code
2	0	1	F	C	0	0	E	Start Version Up Procedure	Updating. Do not turn off.	Error Code
2	0	0	7	C	0	0	F	Version Up Error	Error Code : 0xXXXXXXXX	Error Code
2	0	0	7	C	0	1	0	Version Up Error	Error Code : 0xXXXXXXXX	Error Code
2	0	0	E	C	0	1	1	AACS Error	The prohibited transaction was executed by the content.	Error Code
2	0	0	F	C	0	1	2	AACS Error	This disc is not available for this player.	Error Code
2	0	1	0	C	0	1	3	AACS Error	Playback is prohibited. The playback is stopped.	Error Code
2	0	1	1	C	0	1	4	AACS Error	Failed to verify the content. The playback is stopped.	Error Code
2	0	1	2	C	0	1	5	AACS Error	Management system error occurred. Please call Toshiba Customer Support.	Error Code
2	0	1	3	C	0	1	6	AACS Error	System error occurred.	Error Code
2	0	*	*	C	0	1	7	AACS Error	Cannot play the disc. Error code : 0x00000000	Error Code
2	0	*	*	C	0	1	8	AACS Error	Cannot play the disc. Error code : 0x00000000	Error Code
2	0	*	*	C	0	1	9	Initialization Error	Cannot play the disc. Error code : 0x00000000	Error Code
2	0	*	*	C	0	1	A	Celeron CPU Interconnection Error	Cannot play the disc. Error code : 0x00000000	Error Code
2	0	*	*	C	0	1	B	File creation error	Cannot play the disc. Error code : 0x00000000	Error Code
2	0	*	*	C	0	1	C	internal error	Cannot play the disc. Error code : 0x00000000	Error Code
2	0	*	*	C	0	1	D	DISCID.DAT,Playlist Error	Cannot play the disc.	Error Code
2	0	*	*	C	0	1	E	internal error	Cannot play the disc. Error code : 0x00000000	Error Code
2	0	*	*	C	0	1	F	advanced error	Cannot play the disc. Error code : 0x00000000	Error Code
4	0	*	*	C	5	0	1	Disc unreadable error	Cannot play the disc. Check the disc.	Error Code
4	0	*	*	C	5	0	2	50Hz HD DVD warning	Cannot play the disc.	Error Code
4	0	*	*	C	5	0	3	AACS Error		Error Code
4	0	*	*	C	5	0	4	Contents Error	Cannot play the disc. Error code : 0x00000000	Error Code
4	0	*	*	C	5	0	5	No File	Cannot play the disc. Error code : 0x00000000	Error Code
4	0	*	*	C	5	1	6	AACS Error	Failed to verify the content. The playback is stopped.	Error Code
4	0	*	*	C	5	1	A	AACS Error	System error occurred.	Error Code
4	0	*	*	C	5	F	E	unexpected error	Cannot play the disc. Error code : 0x00000000	Error Code

External Error Code								Content of Error	OSD	VFD
4	0	*	*	C	8	1	3	AACS Error	The prohibited transaction was executed by the content.	Error Code
4	0	*	*	C	8	1	4	AACS Error	This disc is not available for this player.	Error Code
4	0	*	*	C	8	1	5	AACS Error	Playback is prohibited. The playback is stopped.	Error Code
4	0	*	*	C	8	1	6	AACS Error	Failed to verify the content. The playback is stopped.	Error Code
4	0	*	*	C	8	1	7	AACS Error	Management system error occurred. Please call Toshiba Customer Support.	Error Code
4	0	*	*	C	8	1	A	AACS Error	System error occurred.	Error Code
4	0	*	*	C	0	0	3	Contents Error	Cannot play the disc. Error code : 0x00000000	Error Code
4	0	*	*	C	0	0	4	System Error	Cannot play the disc. Error code : 0x00000000	Error Code
4	0	*	*	C	0	0	8	Secure Access Controller Failure	Cannot play the disc. Error code : 0x00000000	Error Code
4	0	*	*	C	0	0	B	Resource Load Failure	Cannot play the disc. Error code : 0x00000000	Error Code
4	0	*	*	C	0	0	C	Script Failure	Cannot play the disc. Error code : 0x00000000	Error Code
4	0	*	*	C	0	0	D	Markup Error	Cannot play the disc. Error code : 0x00000000	Error Code
4	0	*	*	C	2	0	3	Playlist Error	Cannot play the disc. Error code : 0x00000000	Error Code
4	0	*	*	4	6	0	0	Graphics critical Error	Cannot play the disc. Error code : 0x00000000	Error Code
4	0	*	*	4	6	0	1	Pixel Buffer Error	Cannot play the disc. Error code : 0x00000000	Error Code
4	0	*	*	4	6	0	3	Unexpected Error	Cannot play the disc. Error code : 0x00000000	Error Code
4	0	8	B	C	7	0	0	Network API Error	Cannot play the disc. Error code : 0x00000000	Error Code
4	0	8	B	C	7	0	1	DISCID.DAT Error	Cannot play the disc. Error code : 0x00000000	Error Code
4	0	8	B	C	7	1	0	Illegal Input File	Cannot play the disc. Error code : 0x00000000	Error Code
4	0	8	B	C	7	1	1	AACS Initialize Error	Cannot play the disc. Error code : 0x00000000	Error Code
4	0	8	B	C	7	1	3	Illegal AACS call	Cannot play the disc. Error code : 0x00000000	Error Code
4	0	8	B	C	7	1	A	System Error	Cannot play the disc. Error code : 0x00000000	Error Code
4	0	8	B	C	7	F	E	Network API Critical Error	Cannot play the disc. Error code : 0x00000000	Error Code

*OSD is a display of the TV monitor screen.

*VFD is a display of the indicator of the front panel

2. Update Error

Error Code								Contents of Error	Remark
2	0	*	*	C	5	0	1	Decryption Error	
2	0	*	*	C	5	0	2	Decryption Error	
2	0	*	*	C	5	0	8	Same Version	
2	0	*	*	C	5	1	0	file read error	
2	0	*	*	C	5	1	1	file read error	
2	0	*	*	C	5	1	8	Memory Error	
2	0	*	*	C	5	1	9	Memory Error	
2	0	*	*	C	5	2	1	File Error	
2	0	*	*	C	5	2	2	Network Error	Wrong Network Setting
2	0	*	*	C	5	2	3	Proxy Error	Wrong Network Setting
2	0	*	*	C	5	2	4	Proxy Error	Wrong Network Setting
2	0	*	*	C	5	2	5	Proxy Error	LAN connection error
2	0	*	*	C	5	2	6	connect error	
2	0	*	*	C	5	2	7	connect error	
2	0	*	*	C	5	2	8	server error	line busy
2	0	*	*	C	5	2	9	server error	line busy
2	0	*	*	C	5	2	A	server error	line busy
2	0	*	*	C	5	2	B	SSL error	
2	0	*	*	C	5	2	C	SSL error	
2	0	*	*	C	5	2	D	SSL error	
2	0	*	*	C	5	2	E	SSL error	
2	0	*	*	C	5	2	F	SSL error	
2	0	*	*	C	5	3	0	SSL error	
2	0	*	*	C	5	3	1	SSL error	
2	0	*	*	C	5	3	2	SSL error	
2	0	*	*	C	5	3	3	CRL error	
2	0	*	*	C	5	3	4	verification error	
2	0	*	*	C	5	3	5	CRL error	
2	0	*	*	C	5	3	6	CRL error	
2	0	*	*	C	5	3	7	CRL error	
2	0	*	*	C	5	3	8	CRL error	
2	0	*	*	C	5	3	9	verification error	
2	0	*	*	C	5	3	A	verification error	
2	0	*	*	C	5	3	B	verification error	
2	0	*	*	C	5	3	C	verification error	
2	0	*	*	C	5	3	D	verification error	
2	0	*	*	C	5	3	E	verification error	
2	0	*	*	C	5	3	F	verification error	
2	0	*	*	C	5	4	0	verification error	clock setting
2	0	*	*	C	5	4	1	verification error	
2	0	*	*	C	5	4	2	verification error	
2	0	*	*	C	5	4	3	verification error	
2	0	*	*	C	5	4	4	Application Error	
2	0	*	*	C	5	4	5	Memory Error	
2	0	*	*	C	5	4	6	verification error	
2	0	*	*	C	5	4	7	verification error	
2	0	*	*	C	5	4	8	verification error	
2	0	*	*	C	5	4	9	verification error	
2	0	*	*	C	5	4	A	authority and subject key identifier mismatch	
2	0	*	*	C	5	4	B	not match serial number	
2	0	*	*	C	5	4	C	verification error	
2	0	*	*	C	5	4	D	not valid time	clock setting

Error Code								Contents of Error	Remark
2	0	*	*	C	5	4	E	not valid time	clock setting
2	0	*	*	C	5	4	F	long path name	
2	0	*	*	C	5	5	0	verification error	
2	0	*	*	C	5	5	1	server error	line busy
2	0	*	*	C	5	5	2	server error	line busy
2	0	*	*	C	5	5	3	server error	line busy
2	0	*	*	C	5	5	4	SSL error	
2	0	*	*	C	5	5	5	data size error	
2	0	*	*	C	5	5	6	data size error	
2	0	*	*	C	5	7	0	Drive Error	
2	0	*	*	C	5	7	1	Drive manufacturer Error	
2	0	*	*	C	5	7	2	Drive Error	
2	0	*	*	C	5	7	3	Drive Error	
2	0	*	*	C	5	9	0	Drive Error	
2	0	*	*	C	5	9	1	flash memory error	
2	0	*	*	C	5	9	2	flash memory error	
2	0	*	*	C	5	9	3	flash memory error	
2	0	*	*	C	5	9	8	flash memory error	
2	0	*	*	C	5	9	9	flash memory error	
2	0	*	*	C	5	9	A	flash memory error	
2	0	*	*	C	5	A	0	flash memory error	VR NAND
2	0	*	*	C	5	A	1	flash memory error	VR NAND
2	0	*	*	C	5	A	2	flash memory error	VR NAND
2	0	*	*	C	5	A	3	Memory Error	memory shortage
2	0	*	*	C	5	A	4	Memory Error	memory shortage
2	0	*	*	C	5	A	5	Memory Error	memory shortage
2	0	*	*	C	5	A	6	flash memory error	VR NAND
2	0	*	*	C	5	A	7	flash memory error	VR NAND
2	0	*	*	C	5	A	8	flash memory error	VR NAND
2	0	*	*	C	5	A	9	flash memory error	VR NAND
2	0	*	*	C	5	A	A	flash memory error	VR NAND
2	0	*	*	C	5	A	B	flash memory error	VR NAND
2	0	*	*	C	5	A	C	flash memory error	VR NAND
2	0	*	*	C	5	A	D	flash memory error	VR NAND
2	0	*	*	C	5	A	E	flash memory error	VR NAND
2	0	*	*	C	5	C	0	machine code error	
2	0	*	*	C	5	C	1	hardware type unmatched	
2	0	*	*	C	5	C	2	hardware type unmatched	
2	0	*	*	C	5	C	3	same version	
2	0	*	*	C	5	D	8	not good version up image	
2	0	*	*	C	5	D	9	memory write error	
2	0	*	*	C	5	D	A	memory write error	
2	0	*	*	C	5	D	B	memory write error	
2	0	*	*	C	5	E	0	Drive firmware version up error	
2	0	*	*	C	5	E	1	internal command error	
2	0	*	*	C	5	E	2	internal command error	
2	0	*	*	C	5	E	3	internal command error	
2	0	*	*	C	5	E	4	internal command error	
2	0	*	*	C	5	F	1	internal command error	
2	0	*	*	C	5	F	2	internal command error	

SUPPLEMENT3. TROUBLESHOOTING

3-1. Standby LED (red) does not light.

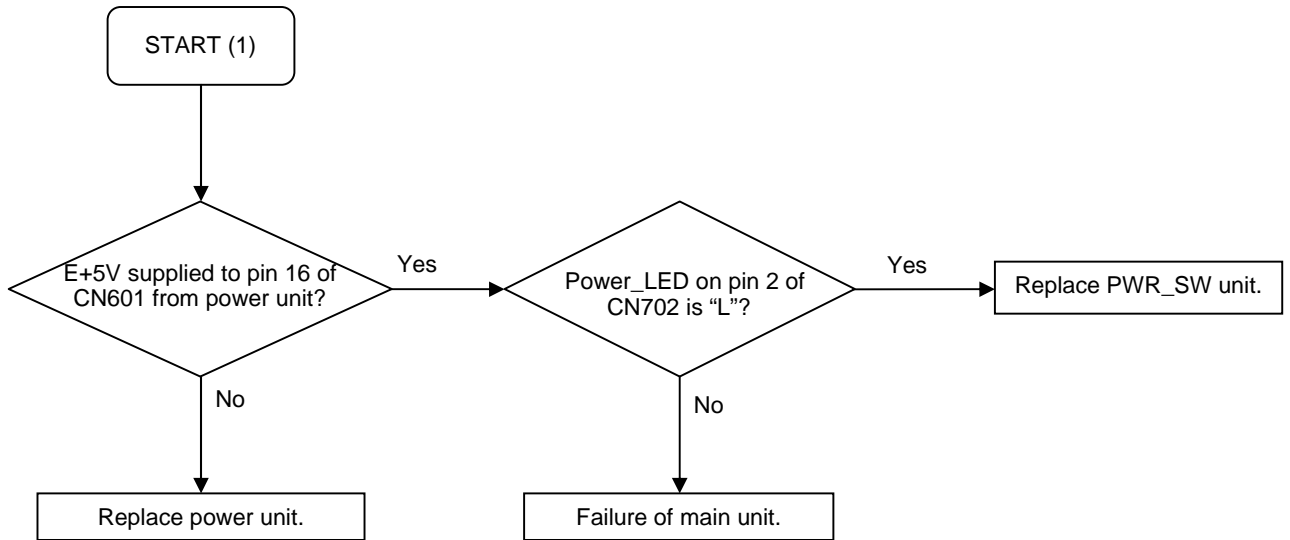

3-2. LED (green) does not light at power on.

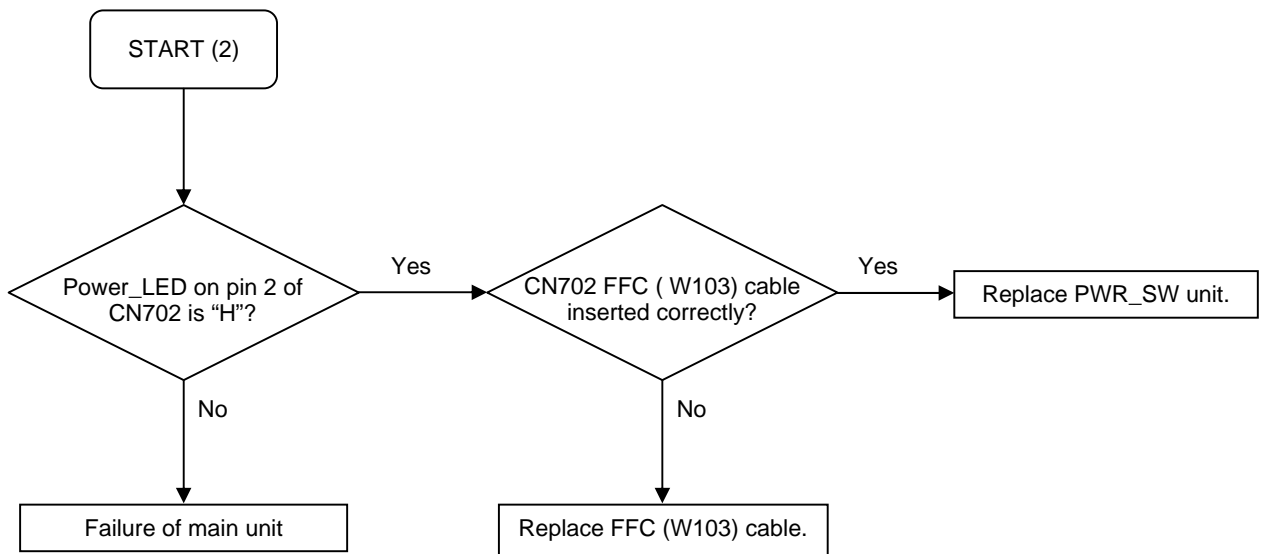

3-3. CPU FAN does not work.

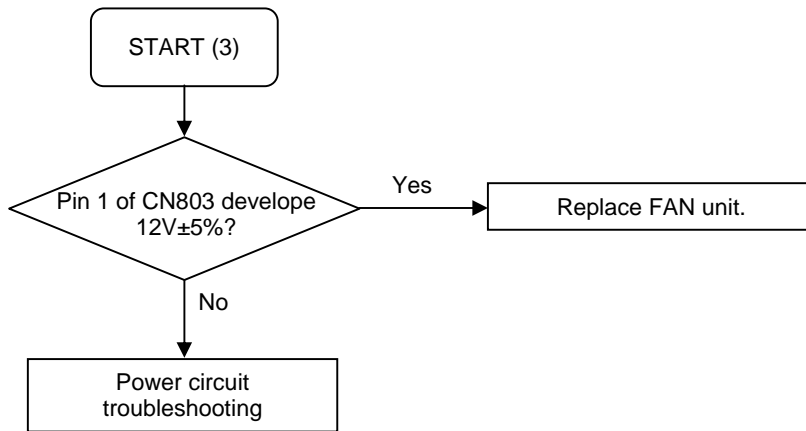

3-4. Indicator does not light. ("WELCOME" does not light at startup.)

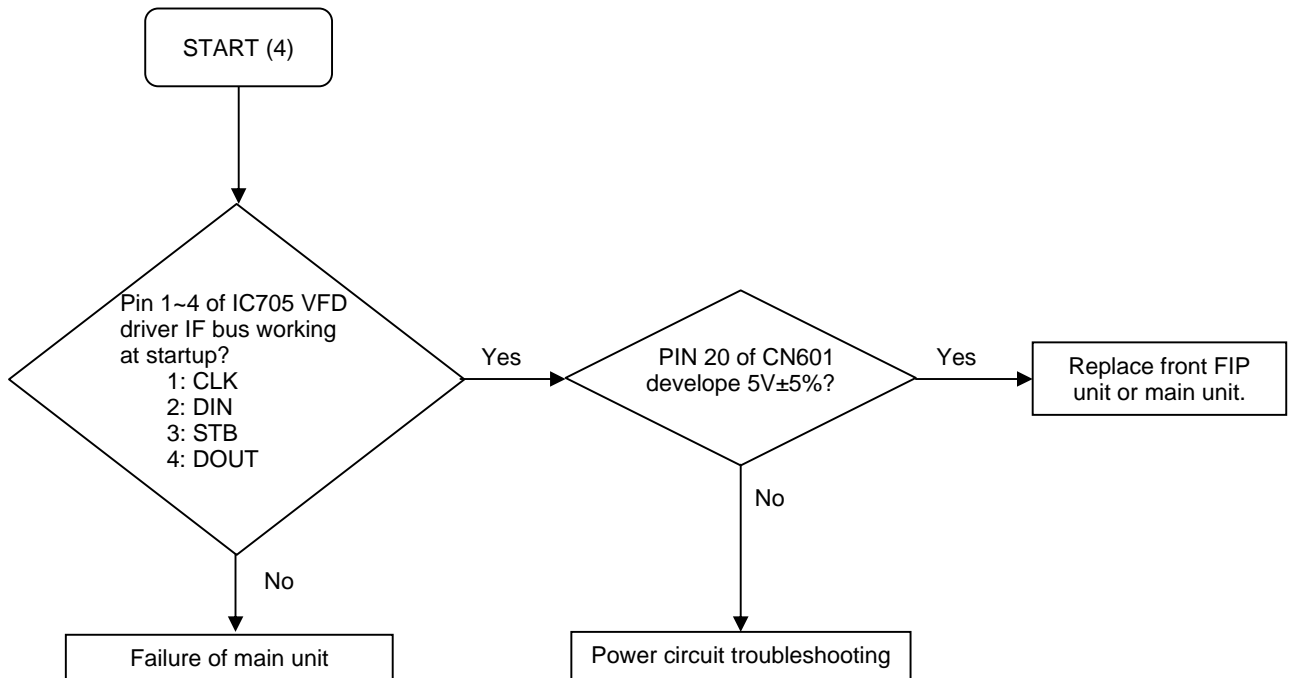

3-5. System does not run. ("WELCOME" displayed and key operation disabled)

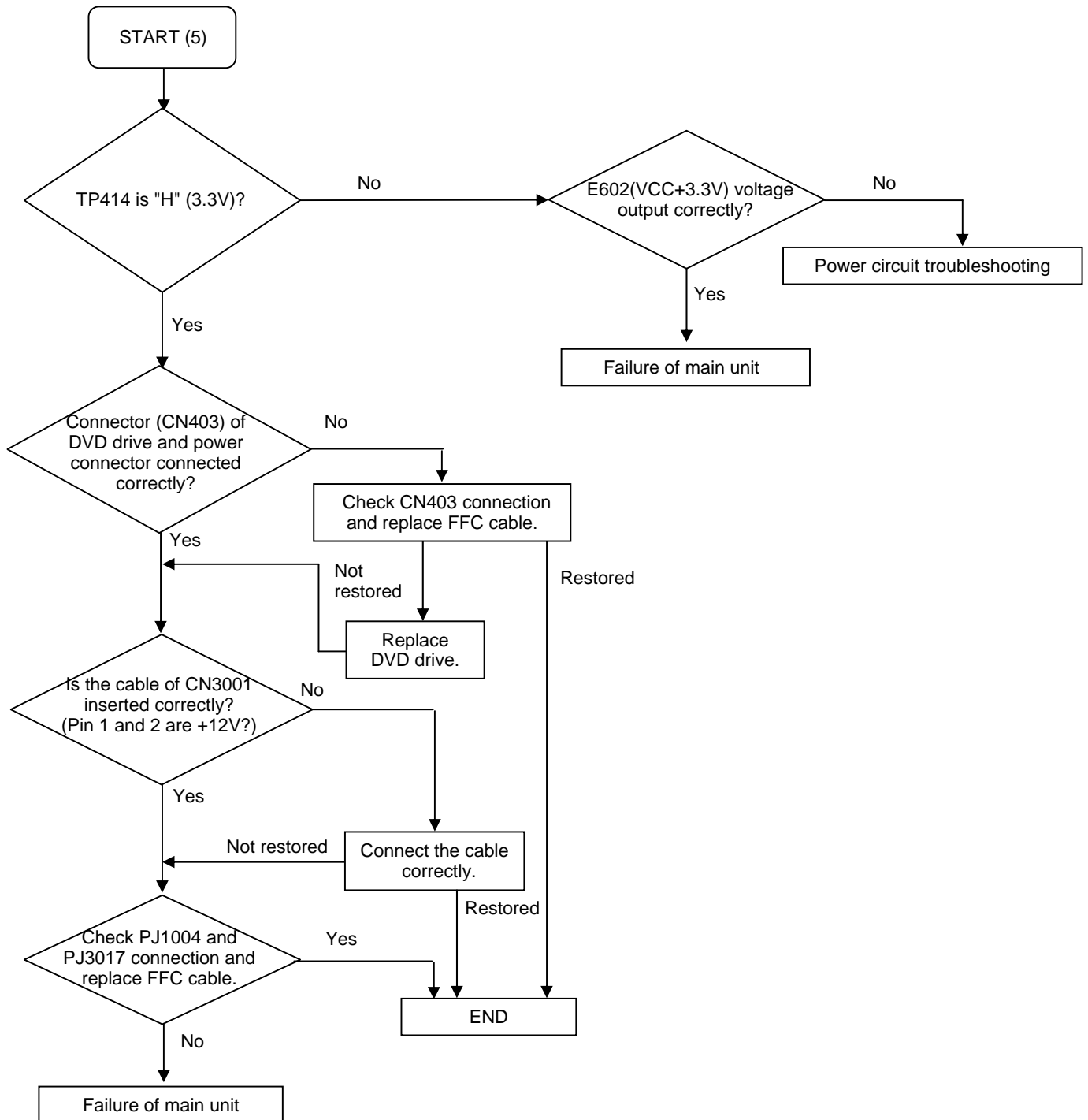

3-6. No picture appears.

- Before repair, confirm the connection with a TV set and the settings of DVD player.

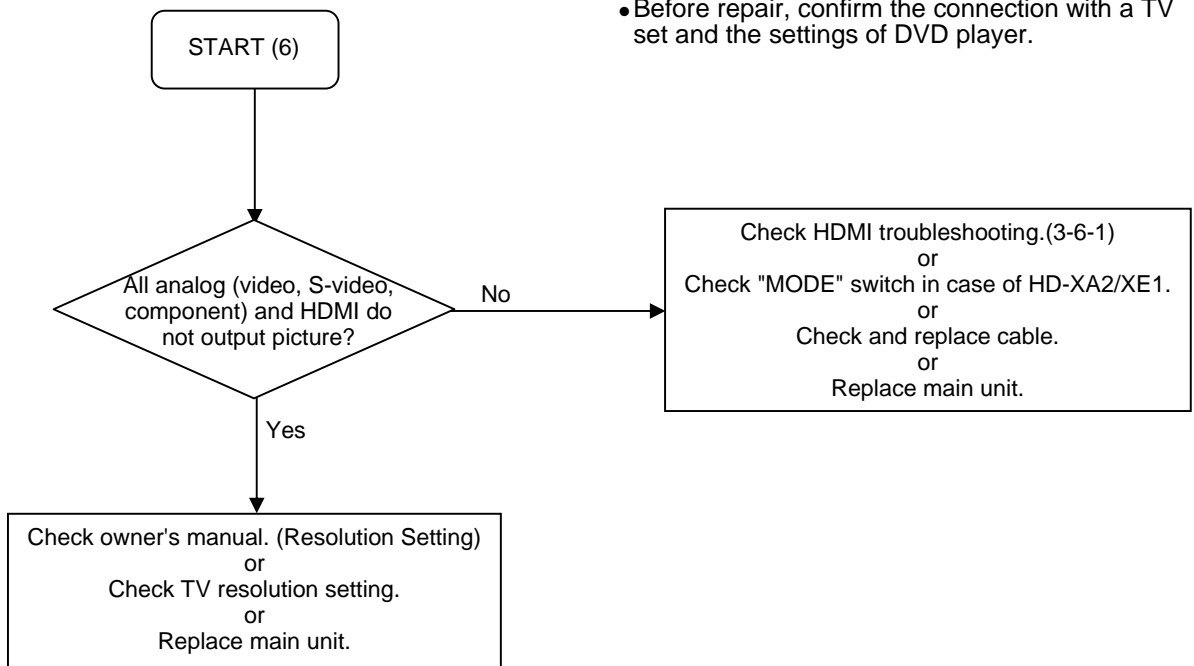

3-6-1. No output from HDMI.

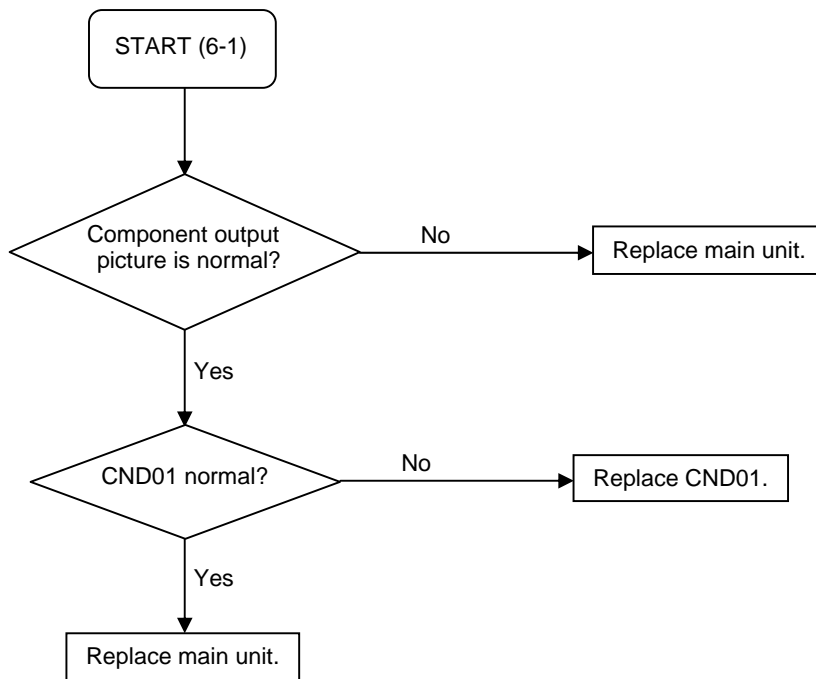

3-7. No audio is played back.

- Before repair, confirm the connection with a TV set and the settings of DVD player.

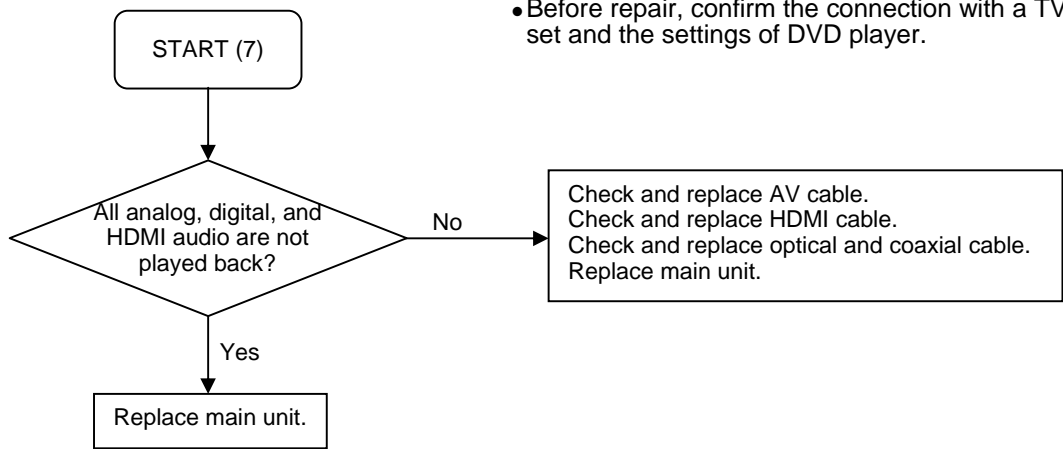

3-8. Buzzer does not sound.

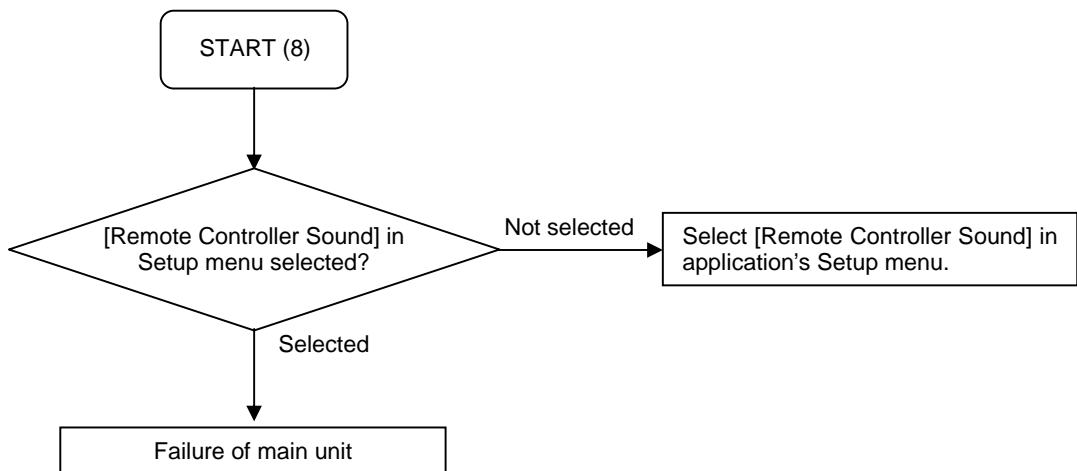

3-9. Extension port does not work.

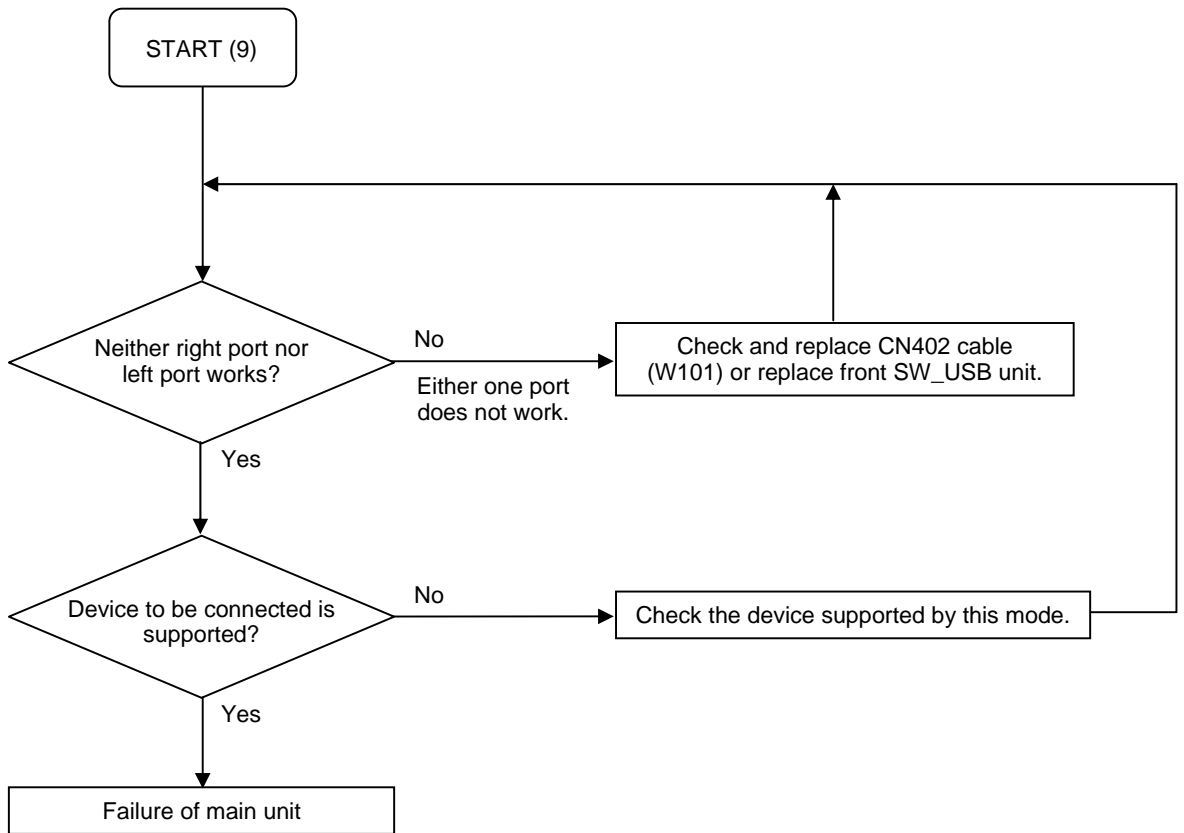

3-10. Front panel keys/remote control are disabled.

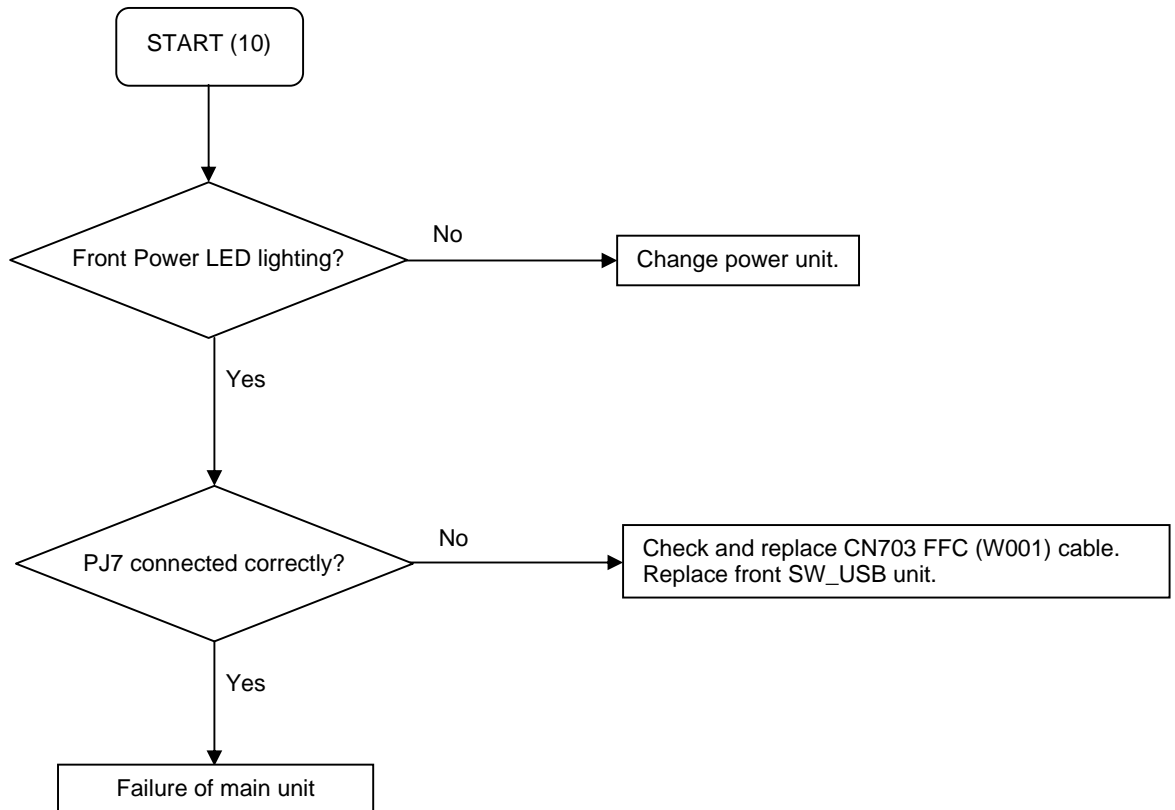

3-11. Other Symptoms

- Improper LAN connection
LAN depends on the quality of the environment and lines to which LAN is connected. Check the DVD player as well as network settings, cables, and connected devices.
- Improper CONTROL pin connection
Use a serial cross cable to connect the unit to a PC.

Check the above. However, if the problem still remains, the main unit may be faulty.

3-12. Power Circuit Troubleshooting

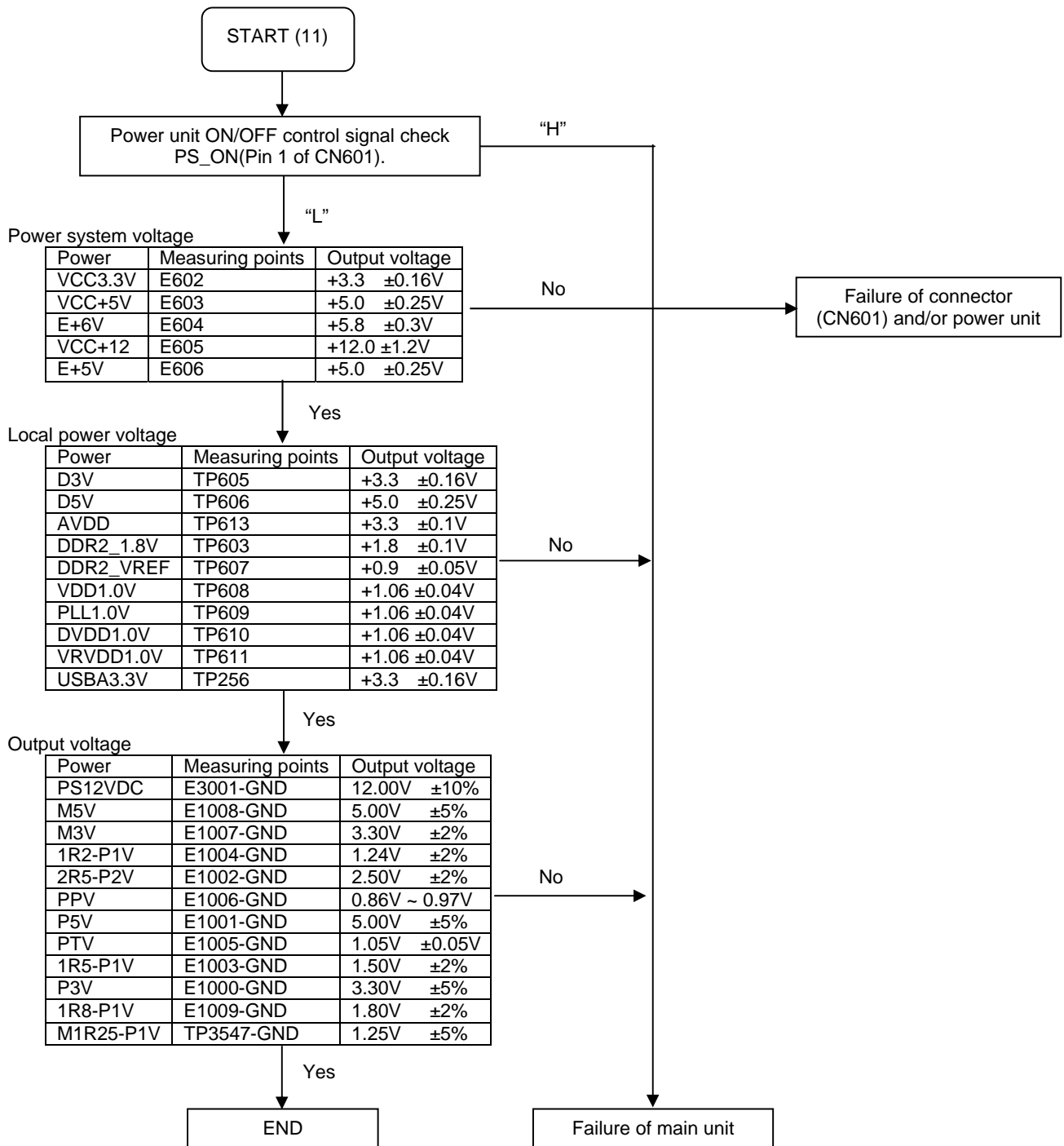

SPECIFICATIONS

Power requirement	50.0W
Power supply	220-240V AC 50/60Hz
Mass	6.2kg
External dimension	Width 438 x Height 74.4 x Depth 344mm
Signal system	Standard PAL/NTSC colour TV system
Laser	Semiconductor laser, Wavelength: 405nm/650nm/780nm
VIDEO output	1.0Vp-p (75Ω), Sync signal negative, Pin jack x 1 system
S-VIDEO output	(Y) 1.0Vp-p (75Ω), Sync signal negative, (C) 0.286Vp-p (75Ω), 1 at rear Mini DIN4 Pin x 1 system
COMPONENT output (Y, P _B , P _R)	Y output (green), 1.0Vp-p (75Ω), Sync signal negative, Pin jack x 1 system P _B , P _R output (blue, red), 0.7Vp-p (75Ω), Pin jack x 1 system each
ANALOG AUDIO output	2.0V (rms), 2.2kΩ or below, pin jack (L, R) x 1 system, 2.0V (rms), 2.2kΩ or below, pin jack Pin jack x 6
DIGITAL AUDIO OUTPUT (BITSTREAM/PCM jack)	Optical connector x 1 system, Coaxial pin jack x 1 system, 0.5Vp-p (75Ω)
LAN port	100BASE-TX/10BASE-T x 1
EXTENSION port	EXTENSION port x 2 systems
RS-232C connector	DSUB 9 pin
HDMI output	19 pin
Remote control	Wireless remote control (SE-R0251)
Operating conditions	Temperature: 41°F ~ 95°F (5°C ~ 35°C), Position: Horizontal
Clock accuracy	Quartz (monthly deviation: approximately ±30 seconds)

- Designs and specifications are subject to change without notice.
- This model may not be compatible with features and/or specifications that may be added in the future.
- The illustrations and screens described in this manual may be exaggerated or simplified for easy recognition and may be slightly different from the actual unit.

TOSHIBA CORPORATION

1-1, SHIBAURA 1-CHOME, MINATO-KU, TOKYO 105-8001, JAPAN